



McGEE COMPANY

SINCE 1951

Denver • Salt Lake
Albuquerque • Dallas • Atlanta

1-800-525-8888

www.McGeeCompany.com

Automotive Service Equipment

Tire Service Supplies

Retreading Equipment & Supplies

Passenger/Truck/OTR

EXPIRES 2/28/2024

All prices are F.O.B. our warehouse unless otherwise specified.
Lease figures are approximate and subject to change.



PRICES SUBJECT TO CHANGE
VISA AND MASTERCARD ACCEPTED
2% Service fee on all credit cards



Premium Quality Chemical Vulcanizing Rubber Patches

Stems Repair Unit



JSU - Combi

Note: The JET Combi may only be used when the angle of the injury is LESS THAN 25°. If the injury angle is GREATER THAN 25°, repair with the appropriate two-piece stem and repair unit.



Repair Unit	Inch	mm	Cutter	Qty/Box	Price
SCU03	1/8	3	BU18T	24	\$25.99
SCU06	1/4	6	BU14T	24	\$31.99
SCU08	5/16	8	BU516N	24	\$38.99
SCU10	3/8	10	BU38T	10	\$32.99

5-Gallon Bead Seater

- 5-gallon capacity
- Equipped with a butterfly valve for maximum air discharge
- Designed for commercial use on large truck tires, passenger and ATV tires to 24.5"
- Made in Taiwan



473-01500
5-Gallon
Bead Seater

\$179.99

Brake Thickness Gauge

NS3218P - \$17.99

- Quickly and easily determine the remaining thickness of a vehicle's brake pads without removing any wheel components
- Color coded gauge determines if the brake pads need to be replaced
- 11mm or more - Green, no replacement necessary
 - » 8mm to 10mm - Yellow, suggest replacement soon
 - » 0mm to 8mm - Red, recommend replacement
- User is able to measure distance with one motion of aligning the gauge and press to measure

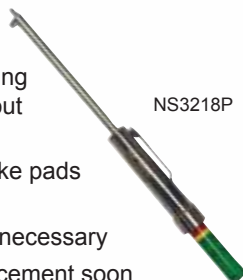

NS3218P

MA2312G

- McGee 1/2" Drive rubber grip 2" extended anvil impact wrench.
- 8,000 RPM
- 600 ft/lbs torque
- Twin handle mechanism

\$109.99



MA2312G

LED Rechargeable Pen Light

- Aluminum pen light with laser and UV light
- Top UV light, wavelength: 365NM
- Side 5W COB FLOODLIGHT: 450 lumen
- Tail light: 3W SPOTLIGHT white LED lumen + red laser light
- Power source: rechargeable Li-ion battery
- Includes: 50cm USB-C cable
- Charging time: 3 hours
- Run time: COB 2.5 h, white spotlight: 2.5 hours
- 120° rotating metal clip with strong magnet
- Dimming switch with battery indication

AS51H - \$25.99



AS51H LED
Rechargeable
Pen Light

Largest stock of tire chains in the Rocky Mountain Area!

See
page 38



Wide Base Truck
Cam Chains



Autosock



DUO Tractor Chains

ITS600 TPMS, Diagnostics, and Tire Service Tool

- Activates, reads and relearns all known sensors
- OBDII relearn for most vehicles with 99% coverage of OE sensors
- Copy By OBD sensor programming & four MX-Sensor program modes; batch program up to 20 MX-Sensors
- Includes wireless Bluetooth vehicle communication interface (VCI)
- Tire pressure placard value reset
- Read/Clear TPMS system codes & view live data
- Free Wi-Fi software updates for the life of the tool



Free TBE200 while supplies last!
ProUpgrade \$120



- Rapid VIN acquisition via optical VINScan
- QR Code Scan / Barcode Scan, Plate scan, Auto VIN detect and manual input
- Identify MMY and sensor OE part number via VIN decoding



TBE in action

Integrate with the TBE200 for:

- Precise laser measurement of tread depth & brake disc wear
- Create comprehensive Test Report w/ TPMS health, Tread depth, brake disc wear characteristics, & Repair tips

TBE200 \$449.99

Ask us about our competitor tool trade up program

\$799.00 Bundle with 12 sensors only*

*Tool sold separately as well

MaxiTPMS[®]
ITS600K12

AUTEL[®]

Sick of your technicians not being able to read tire DOT codes or read what they wrote down?



ITS600 is the first tool to scan DOT numbers for expiration and recall lookup!

TBE200 Video



ITS600 Video



46130100 - PRE-PROGRAMMED TESLA BLUETOOTH TPMS SENSOR

- The MX-Sensor BLE is a pre-programmed Bluetooth Low Energy (BLE) sensor that offers "fit & go" capability for:

- Tesla Model 3 2021-2023
- Tesla Model S 2021-2023
- Tesla Model X 2021-2023
- Tesla Model Y 2020-2023

- All Tesla models older than the years above use our standard Ascot by Autel MX Sensor 1-Sensor
- Built to meet or exceed industry standards and tested to endure extreme temperatures, the MX-Sensor BLE is also programmable with Autel tools for the latest BLE-equipped vehicles
- The MX-Sensor BLE is warranted for two years

NEW



\$49.99

AUTEL MX-SENSOR PROGRAMMABLE UNIVERSAL TPMS SINGLE SENSOR

Metal stems available in Black, Titanium, Chrome, & Rubber

- Combines 315MHz & 433MHz frequencies into a single sensor • 98% vehicle coverage • The exclusive MX-Sensor patented PRESS release valve allows rubber and metal valve stems to freely interchange by hand without requiring a tool • Built to match or exceed OEM sensors in frequency strength and durability
- 100% ID cloneable with no relearn required • Quickly update during installation with an Autel wireless programming tool



Qty discounts available!

Ascot No.	McGee No.	Description	Price
461-20326	1-Sensor	Autel MX-Sensor Programmable Universal TPMS Single Sensor	\$27.99 Quantity breaks available

FREE SOFTWARE UPDATES



Quick Mode

BASIC FUNCTIONS

EASY & FAST

- Activate All Known TPMS Sensors
- Read Sensor ID, Temperature, Pressure
- Read Sensor Battery Condition
- On-Tool OE Sensor Information
- Program MX-Sensor With 3 Programming Options
- Batch Program 1-16 MX-Sensors

\$360*

MaxiTPMS[®]
TS508K12

- 1 - Autel TS508 Complete TPMS Tool
- 4 - Metal Valve Stems
- 12 - 1Sensor TPMS Programmable Sensors
- Wifi Version Available



Advanced Mode

COMPLETE FUNCTIONS

POWERFUL

- Same TPMS Features as Quick Mode
- TPMS Status Screen - View System Faults
- Read & Clear TPMS DTCs
- On-Tool DTCs Description
- Program MX-Sensors by Copying ECU Sensor IDs
- On-Tool Relearn Procedure Guide
- Widest Vehicle Coverage For OBD Relearn
- Tire Pressure Placard Value Reset

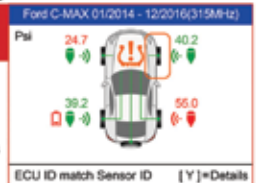

AUTEL TPMS TOOL

- The MaxiTPMS[®] TS508 is a new generation TPMS diagnostic & service tool specially designed to activate all known TPMS sensors, read TPMS sensor status, check TPMS system health condition, program MX-sensors and conduct TPMS relearn
- With Quick Mode and Advanced Mode options, you can save time and energy by choosing the most suitable way to complete TPMS work

FREE SOFTWARE UPDATES

ACTIVATE ALL KNOWN TPMS SENSORS



TS508K

TPMS Profit Center

Remember, replacing the TPMS valve stem (snap-in rubber or clamp-in aluminum) or the TPMS service kit with each tire sale is done for the same reasons a traditional TR-413 snap-in is replaced with each new tire.

More information at mcgeecompany.com/stems



TPC
\$184.99

- McGee's top 7 stems
 - * 8 - VS70
 - * 4 - 1096k
 - * 4 - VS90
 - * 8 - VS65
 - * 8 - 9066K
 - * 20 - VS950
 - * 4 - VS20
- Color coded for easy selection
- 52 stems
- Extra dividers to fit your needs
- Heavy duty protective organizing case



How much money are you leaving on the table by not doing TPMS?

ASSUMPTIONS	TR413 Valve Stem	TPMS Rebuild 9066k
	100 Tires per Week	100 Tires per Week
Cost to WD	\$ 0.29	\$ 4.03
Sell price	\$ 1.90	\$ 8.95
Profit per tire	\$ 1.61	\$ 4.92
Weekly profit	\$ 161.00	\$ 492.00
Annual profit (52 weeks)	\$ 8,372.00	\$ 25,584.00

A shop doing TPMS makes over **three** times the amount doing TPMS versus valves alone in addition to pushing their customers to a competitor. **Be TPMS smart**; let McGee Company train you and set you up with the tools to be successful.

REDI-Sensor™

Simple and Accurate REDI-SENSOR MULTI-APPLICATION SENSOR



- Installs right out of the box • No programming required, saving you 8-10 minutes per vehicle • Reduces replacement sensor inventory • Adjustable valve stem design • Fits over 90% of the market • No additional training required • All REDI-Sensors are available in a rubber stem format

WORKS WITH EXISTING MAJOR TPMS SCAN TOOLS:

If a shop has the tools to handle OE sensors, it's ready for REDI-Sensor. Unlike other sensors that require the purchase of specialized tools and software upgrades, no additional purchases, training or investments are needed with REDI-Sensor.

McGee No.	Description	Price	Ascot No.
46107001	315MHz REDI-Sensor Multi-Application Sensor (Clamp-In Style)	\$33.14	461-07001
46107002	315 MHz REDI-Sensor for Honda, Hyundai, Kia, Lexus, Toyota & Scion	\$34.57	461-07002
46107003	315MHz REDI-Sensor Multi-Application Sensor (Clamp-In Style)	\$34.57	461-07003
46107004	433MHz REDI-Sensor Multi-Application Sensor (Clamp-In Style)	\$34.57	461-07004
7001R	315MHz REDI-Sensor Multi-Application Sensor (Snap-In Style)	\$33.14	461-07011
5001R	433MHz Multi-Application Sensor (Clamp-In Style)	\$34.29	

EZ-sensor®

Innovation by Schrader

S57 Tool Features:

- Schrader's strong OE pedigree, EZ-sensor®, and its latest generation EZ-sensor® GO, provides users with 70% EV coverage for national brands. The OE quality sensors cover some of the most popular EV applications in North America, such as:
 - Tesla 3 (2017 – 2020)
 - Ford Mustang Mach-E (2021)
 - Tesla S (2014 – 2021)
 - Nissan Leaf (2011 – 2022)
 - Chevrolet Bolt (2017 – 2022) and more



VEHICLE COVERAGE	ST-1	S57
Universal sensor coverage	EZ-sensor® Exclusive	EZ-sensor® + Other Programmable Sensors
Triggers/scans/reads/activates/relearns 100% OEM sensors	✓	✓
RELEARN FUNCTIONALITY	ST-1	S57
OBDII and Sync-ID (OBDII routines for Ford, Mitsubishi, Suzuki etc.) technologies	✓	✓
Tread depth gauge measurement (PN: 21301)	✓	✓
ECU unlock feature	✓	✓
Clears and retrieves TPMS Diagnostic Trouble Code (DTC) information	✓	✓
Decodes TPMS Diagnostic Trouble Code (DTC) information	✗	✓
HARDWARE & SOFTWARE	ST-1	S57
Keyfob test & PN lookup	✓	✓
WiFi and live update capable	✓	✓
DOT (Department of Transportation) recording	✗	✓
Allows placard pressure adjustments	✓	✓
EZ-sensor® image display capability	✓	✗
ID match function (matches sensor IDs with the ones stored in the vehicle)	✓	✗
Schrader's unique and user-friendly software	✓	✗
Customer/Job management feature	✓	✓
Built-in TPMS tool training	✗	✓
VIN barcode scanner to select Make-Model-Year (US only)	✗	✓
Supports trailer TPMS relearns	✗	✓
Touchscreen	✗	✓
5 years of free software updates	✓	✓

McGee No.	Description	Price
46133560	Dual Band 315 & 433 Mhz EZ Sensor	\$29.99
46133561	Bulk 10 Pack EZ Sensor	\$259.99
46934000	Aluminum Stem for EZ Sensor	\$5.49
VS950	Rubber Stem for EZ Sensor	\$1.99
33700	High Speed EZ Sensor	\$34.99
21355	ST1 Tool with 28 EZ Sensors	\$699.00
21057	S57 Tool w/100 EZ Sensors	\$2,299.00



Designed to eliminate multiple sensors required for TPMS work

APPLICATIONS:

Covers most GM, Chrysler, Honda, Nissan, Toyota, Lexus, Scion, Ford, Lincoln, & Mercury vehicles and some Mitsubishi, Subaru & Suzuki vehicles • Fully programmable • Compatible with Bartec, Schrader and SPX/OTC programming tools • Sensor features Wireless Auto Locate or WAL that allows the vehicle's TPMS system to locate and identify each TPMS sensor's specific location

Do you know what frequency TPMS that car requires?



SAJWJ6HL9GMK27927

S = 1995	2 = 2002	9 = 2009	G = 2016
T = 1996	3 = 2003	A = 2010	H = 2017
V = 1997	4 = 2004	B = 2011	J = 2018
W = 1998	5 = 2005	C = 2012	K = 2019
X = 1999	6 = 2006	D = 2013	L = 2020
Y = 2000	7 = 2007	E = 2014	M = 2021
1 = 2001	8 = 2008	F = 2015	N = 2022

Full Bulletin



POPULAR TPMS KITS AND STEMS

Stem Base:  VS15, VS950, VS950S  VS20  VS30, VS90, VS45  VS1010  VS65* *VS925A & VS925C(silver), VS280SB & VS925B(black)

Ascot No.	McGee No.	Schrader Version	Description	Price
469-01030	1030K	SH20017AK	Siemens Kit for VW (Fits 1053 Sensor) (Orange)	\$3.48
469-01050	1050K	SH20013AK/ SH20030AK	Siemens Kit for Chrysler (White) SH20013AK includes bottom ball	\$3.35
469-01060	1060K	20001/20002/ 20135AK/20096AK	Fits Schrader SH20096 (Red)	\$1.88
469-01070	1070K	20004/20116AK/ 20115AK/20107AK	Fits Dill 9076, 9107, 9115, 9116 (Blue)	\$1.75
469-01080	1080K	20003/20007/ 20117AK/20028AK	Fits Dill 9028, 9034, 9064, 9081, 9117, 9161 (Green)	\$1.75
469-01090	1090K	-	Compatible with Beru Sensors (Grey)	\$3.60
469-20036		SH20036AK	Entire Valve (Schrader 20036) for Hyundai, Kia, Honda (Dill 1096)	\$9.42
469-01100	1100K	SH20032AK	Compatible with Pacific Sensors for Toyota/Lexus (Purple)	\$3.02
469-01110	1110K	SH20006AK	Compatible with Pacific Sensors for Toyota (Teal)	\$2.95
469-01130	1130K	SH20030AK	Compatible with Schrader 20005 (Burgandy)	\$2.95
469-20025	2000K	-	TRW Kit for Honda, Acura	\$3.75
469-20010	2010K	SH20015AK	Compatible with Schrader Sensors for Volvo (non-stock) (Lt. Brown)	\$1.92
469-20030	2030K	SH20016AK	Dill Sensors 9154, 9204, 9214	\$1.95
469-02040	2040K	SH20019AK	Kit for Honda Civic (Lt. Blue)	\$2.13
469-09250	VS925A	-	Aluminum Metal Replacement Valve for GM Snap-In	\$4.43
469-09251	VS925C	-	Chrome Metal Replacement Valve for GM and Ford Snap-In	\$4.53
469-00950	VS950	SH20018	Rubber Snap-In Replacement Valve for GM & Ford fits Schrader 46133500 (ea)	\$1.99
469-17208	VS950IV	VS950IV	Rubber Snap-in like VS950 for GM & Ford (Import)	\$.99
469-09305	VS950SC	-	Chrome Replacement Valve for GM and Ford Snap-In	\$2.63
469-34000	46934000		Alum Stem for Schrader 46133500 dual band	\$5.50
469-20020	-	SH20020	Replacement Stem Chrysler, Uses Kit 1050K	\$2.29
469-90660	9066K	-	Complete Replacement Stem Chrysler with Kit (9066B-Ball joint only)	\$4.48
469-07020	7020K	-	Accessory Kit for Redi Sensor	\$3.95
469-00770	VS70	-	Available on the following vehicle in various forms: Years 2010 to 2014 (Acura, Cadillac, Chrysler, Dodge, Honda, Hyundai, KIA, Mazda, Nissan) the sensor most associated with the VS-70 is 7001/HP or 7002.	\$8.53
469-00080	VS80	-	Replacement Rubber Stem Kit Dill Redi 7001-R	\$5.65
469-00090	VS90	-	Key at base attaches via press clip; Fits Dodge Dart, Mitsubishi Mirage	\$5.25
469-17436	1743016	-	Smart Sensor Snap-In Valve for ITM, Cub, 31Inc, Pilot	\$3.34
469-20014	-	SH20014AK	Kit Fits EZ Sensor 34000 Stem	\$2.13
	VS1010	-	Fits Hyundai Sante Fe Snap-In 7mm	\$2.48
	VS65	-	Base of stem is square Snap-In Fits Dodge Rams, Jeep Cherokee	\$3.94
	VS65IV	-	Base of stem is square Snap-In Fits Dodge Rams, Jeep Cherokee Import	\$2.43
	VS35	-	Dill TPMS clamp-in valve Dodge Ram	\$7.54
	VS965	-	Replacement valve stem for Hyundai / Kia	\$4.27
469-00919	VS919	-	Replacement TPMS stem for 19.5 Trk Wheels, parallel key	\$3.72
	VS241	-	2017 Ford F350 Super Duty dually aluminum	\$5.99
	VS20	-	Rubber Valve Stem for 2015 and newer GM and Ford	\$2.67
469-20280	RV1000	-	Autel MX-Sensor Rubber press release stem	\$3.25
469-20279	MV1000	-	Autel MX-Sensor Metal press release stem	\$3.08
469-20281	CV001	-	Autel Black MX-Sensor Black Metal Valve	\$4.17
469-20282	CV002	-	Autel MX-Sensor Titanium Grey Metal Valve	\$4.17
469-20283	CV003	-	Autel MX-Sensor Chrome Valve	\$9.95
469-17393	VS920	-	.625" valve hole square found in Ford Super trucks/sprinters (VS919 Parallel key)	\$4.47
469-17398	1750398	-	Short Snap in good for custom applications parallel key	\$1.48
	VS490	-	Tesla OEM stem uses T20 screw, aftermarket wheel compatible OE Sensor available PN:2547	\$7.90
	VS15	-	Replacement Valve for Toyota Corolla	\$3.99
	VS312	-	Replacement Clamp in Stem for Toyota TPMS Adapter w/Bent 0.3 90"	\$6.40
	DA543E	-	Valve for GM	\$11.97
	2045K	-	TPMS Accessory Kit Honda Acura TPMS Valve Stem Assy Short TRW	\$2.53
	1096K	-	Ball-seat valve stem assy w/ internal shear ring 43mm	\$7.96



PREMA

Prema Radial Repairs - Passenger and Light Truck

PREMA Center-Over-Injury Repairs are designed for use in all radial tires. The PREMA Radial Repair is intended for use in HOT or COLD applications. PREMA Radial Repairs are designed for use in the crown, sidewall and shoulder of radial tires. Install with PREMA Ultra Fast Dry Vulcanizing Cement. Refer to the PREMA Repair Chart for proper selection of the repair unit. Always fill the injury channel with the appropriate Prema repair material.



Ascot No.	McGee No.	Description	L (in.)	W (in.)	# Plies	Qty/Box	Price
575-05109	PR109	Radial 109	3	1 3/4	1	20	\$28.82
575-05110	PR110	Radial 110	3 1/4	2 1/4	1	20	\$35.34
575-05111	PR110T	Radial 110	3 1/4	2 1/4	1	80	\$127.87
575-05112	PR112	Radial 112	4 3/4	3	1	10	\$27.55
575-15112	PR112B	Radial 112	4 3/4	3	1	40	\$108.40
575-05113	PR113	Radial 112HD	5	3 1/4	1	10	\$32.41
575-05114	PR114	Radial 114	5 1/4	3 1/2	1	10	\$43.68
575-05120	PR120	Radial 120	5	3 1/4	2	10	\$53.04
575-05135	PR135	Radial 135	7 1/2	5 1/2	4	10	\$148.09
575-05140	PR140	Radial 140	7 3/4	4 1/4	3	10	\$126.43

Pre-Buff Cleaner

PREMA Pre-Buff Cleaner is formulated to remove contaminants and silicone from the innerliner of the tire prior to buffing. Contains no ozone depleting chemicals.



Ascot No.	McGee No.	Description	Size	Price
505-00532	PPC32	Pre-Buff Cleaner (Flammable)	32 fl oz	\$19.92
505-00516	PPC16	Pre-Buff Cleaner (Aerosol)	16 fl oz	\$13.63

Prema Universal Repairs

PREMA Universal Repairs are designed for NAILHOLE REPAIRING of tubeless tires in the CROWN area only. Universal Repairs are available in round or square versions. Install with PREMA Ultra Fast Dry Vulcanizing Cement. Always fill the injury channel with the appropriate Prema repair material.



Ascot No.	McGee No.	Description	L (in.)	W (in.)	Qty/Box	Price
550-00502	PUR2	Universal Round 2	2 1/4	--	50	\$40.52
550-00522	PUS2	Universal Square 2	1 3/4	1 3/4	100	\$54.22
550-00533	PUS3	Universal Square 3	2 1/2	2 1/2	100	\$83.02
550-00534	PUS4	Universal Square 4	3	3	50	\$60.06

Ultra Fast Dry Vulcanizing Cement

PREMA Ultra Fast Dry Vulcanizing Cement is formulated to provide outstanding performance when used in conjunction with PREMA Repair Materials. Contains no ozone depleting chemicals.



Ascot No.	McGee No.	Description	Size	Price
501-00508	PFC8	Ultra Fast Dry Vulcanizing Cement (Flammable)	8 fl. oz.	\$14.40
501-00532	PFC32	Ultra Fast Dry Vulcanizing Cement (Flammable)	32 fl. oz.	\$36.03

Rema Minicombi Repair Units & Accessories

Part of Rema's renowned Blue Bonding System™, Minicombi features a metal pilot guide for easy installation and seating. Specially designed for tread area punctures on both radial and bias-ply tires, Minicombi should be used with Special Cement BL.



Ascot No.	McGee No.	REMA#	Description(Units/Box)	Price
581-67050	A3	A3	1/8" Minicombi A3 (50/Box)	\$131.18
581-67340	A6	A6	1/4" Minicombi A6 (40/Box)	\$157.99
581-68008	B8MC	B8-MC	5/16" Minicombi B8 (20)	\$111.99



Rema tire tube patches are renowned for their easy application and extraordinary effectiveness. A unique rubber compound allows the patch to stretch evenly and equally in all directions upon inflation, assuring a reliable bond and minimal bulging in any service condition.

Ascot No.	McGee No.	Units Size	Per Box	Price
541-00410	1	1-1/2" Round	30	\$9.92
541-00420	2	1-3/4" Round	30	\$17.26
541-00430	3	2" Round	30	\$22.21

Patch should be 1/2-inch larger in both width and length than the injury.

Rema Tip Top Universal Patch

The Hole Solution™ - The only patch you'll ever need for making a nail hole repair. For radial and bias-ply passenger or truck tires.



Ascot No.	REMA No.	Injury Size	Qty.	Price
550-26707	UP3	Small Nailhole	100	\$73.99
550-26714	UP45	3/16" Nailhole	300	\$329.99
550-26721	UP6	1/4" Nailhole	50	\$81.87
550-26745	UP8	5/16" Nailhole	50	\$108.99

RAD 100 Series Radial Repair Units

RL110 Bulk 30 Per Bag - \$44.75

REMA RAD 100 Series center-over-injury repair units. Due to our fully-integrated blue bonding layer and center over injury design, REMA TIP TOP Radial-Ply repair units are suitable for use with all current vulcanizing systems. For best results, always select the corresponding REMA TIP TOP Stem insert unit.



Ascot No.	McGee No.	Patch Size Inches	(mm)	Qty/Box	Price
575-00110	RAD110	2 x 2-3/4	55 x 75	20	\$54.99
575-00115	RAD115	3-1/2 x 3	70 x 115	10	\$66.99
575-00120	RAD120	4-7/8 x 3	85 x 130	10	\$65.99



Sick of the tin covers?

NEW

Try our
SOLID CHROME
solutions

180 - 18 Labeled Drawer Metal Storage Cabinet available



Sold as Pack

Ascot No	McGee No	HEX	Thread	Length	Application	Price Pack 20	Per Nut
491-11001	LN01	13/16"	M14x2.0	2.17"	Ford	\$55.60	\$2.78
491-11002	LN02	3/4"	M12x1.50	1.36"	Honda/Acura	\$21.00	\$1.05
491-11003	LN03	7/8"	M14x1.50	1.65"	Dodge/Chevy/Buick/Ram/Jeep	\$34.00	\$1.70
491-11004	LN04	7/8"	M14x1.50	1.77"	Chevy/GM/Buick	\$41.00	\$2.05
491-11005	LN05	7/8"	9/16" - 18	1.65"	Dodge	\$34.00	\$1.70
491-11006	LN06	13/16"	1/2"-20	1.38"	GM/Ford	\$21.00	\$1.05
491-11007	LN07	13/16"	M12x1.25	1.38"	Nissan/SUB	\$21.00	\$1.05
491-11008	LN08	13/16"	M12x1.50	1.38"	Accura/GM	\$21.00	\$1.05
491-11009	LN09	13/16"	M12x1.25	1.46"	Nissan/infiniti	\$39.50	\$1.98
491-11010	LN10T	13/16"	M12x1.50	1.46"	Toyota	\$37.00	\$1.85
491-11011	LN11	7/8"	M14x1.50	1.81"	Lexus	\$65.60	\$3.28
491-11012	LN12	3/4"	M12x1.50	1.71"	Dodge/Chrysler	\$53.60	\$2.68
491-11013	LN13	3/4"	1/2"-20	1.38"	Chevy/Dodge/Ford/GM/Jeep/Mazda/Mercury	\$53.60	\$2.68
491-11014	LN14	3/4"	M12x1.50	1.24"	Ford	\$29.00	\$1.45
491-11015	LN15	3/4"	M12x1.50	1.38"	GM/Ford	\$21.00	\$1.05
491-11016	LN16	3/4"	M12x1.25	1.38"	Chevy/Infinity/Nissan	\$21.00	\$1.05
491-11018	LN18	13/16"	M14x1.50	1.65"	Ford	\$39.00	\$1.95
491-11017	LN17	3/4"	M12x1.25	2.2" (1.1" threads)	Jeep/Renegade/Chrysler	\$48.00	\$2.40

Tire Denailer \$11.99

- Blade length 3" • Point diameter 5/16"
- Made in USA

Developed by a tire repairman to probe the injury and push the nail back through the tire. Probe has a recess at the tip to accept the point of a nail or other puncturing object.



Ascot No.	Mfg. No.	Description	Price
537-15227	23113IR	Insert Tool Open Needle	\$4.65
537-15230	20000	Insert T Handle Open Needle	\$22.90

Ask us about a tire repair cabinet to keep organized!

JET Radial Repairs - Passenger and Light Truck

JET Center-Over-Injury Repairs are designed for use in all radial tires. The JET Radial Repair is intended for use in HOT or COLD applications. JET Radial Repairs are designed for use in the crown area of radial tires. Install with JET Fast Dry Vulcanizing Cement.



Repair Unit	Size		Qty/Box	Price
	Inch	mm		
SR110	2 3/4 x 2	70 x 50	20	\$16.62
SR110H	3 1/4 x 2 3/8	80 x 60	10	\$10.49
SR112	4 3/8 x 2 1/2	110 x 65	10	\$12.91
SR114	5 3/4 x 3	145 x 75	10	\$21.58
SR120	5 x 3	125 x 75	10	\$20.89
SR122	6 7/8 x 2 3/8	175 x 80	10	\$28.07
SR124	8 1/4 x 3 3/8	210 x 85	10	\$36.81

Additional sizes - SR133, SR140, SR142

Universal repairs - nail hole injuries in crown area only. Advanced cushion gum for max adhesions.

Bias or Radial — Universal Repair Units - Square

Repair Unit	Inch	mm	Qty/Box	Price
SSA45	1 3/4 sq	45 sq	100	\$25.37
SSA45T	1 3/4 sq	45 sq	100	\$23.45
SSA55	2 1/8 sq	55 sq	80	\$27.17
SSA55T	2 1/8 sq	55 sq	100	\$37.47

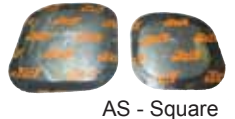

AS - Square

Bias or Radial — Universal Repair Units - Round

Repair Unit	Inch	mm	Qty/Box	Price
SRA45	1 3/4	45	30	\$7.98
SRA45T	1 3/4	45	100	\$21.70
SRA55	2 1/8	55	30	\$9.75
SRA55T	2 1/8	55	100	\$27.60

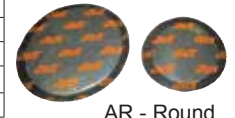

AR - Round

Vulcanized Tubeless Tire Repair Seals

- For emergency repair use only
- String repairs are not designed to be used in lieu of a permanent repair
- Repair a punctured tire in a matter of minutes
- Made from high-strength yarn and butyl rubber



McGee No.	Description	Qty/Box	Price
361UBX	4" Brown String Repair	50	\$11.95
362UBX	8" Brown String Repair	25	\$11.49
370UBX	7" Thin Black String Repair	50	\$11.99

Rema No.	McGee No.	Description	Price
537-95893	261RT	Reamer	\$10.99

- Used to inspect injuries in tires and to remove small stones and debris



Ascot No.	McGee No.	Description	Price
537-00001	1013P	Black Handle Awl	\$9.99

#MTK Pouch - \$25.95



Includes:

1 ea	GA115 Gauge 20-120 PSI
1 ea	MK White Markal
1 ea	1246D Flip Socket 3/4-13/16 Thin Wall
1 ea	1291DT Flip Socket 19mm-21mm
1 ea	595TM Tread Depth Gauge
1 ea	TL620 Core Tool

McGee Company can help you determine the tire repair items needed to get started. Call for details!



McGee Company does not recommend "temporary" tire repairs. All repairs should perform the function of filling or replacing the injured section as recommended by the RMA and other industry associations.

Paintstik® Marker



Markal

Permanent, waterproof and fadeproof. Marks on wet tires, withstands retreading temperatures. Nontoxic, contains no lead. Sold 12 per box. Other colors available.

Ascot No.	McGee No.	Color	Price
459-80257	MKWhite	White	\$13.26
459-80258	MKYellow	Yellow	\$13.52

Carbide Cutting Tools



Part No.	Description	Prices
BU18T	1/8" Taper Burr (PCC1)	\$10.50
BU14T	1/4" Taper Burr (PCC2)	\$41.75
BU38T	3/8" Taper Burr (PCC4)	\$36.81
BU12B	1/2" Ball Burr	\$33.92
BU732N	7/32" Long Pointed Burr (Use with 1/4" Plug)	\$40.69
BU516N	5/16" Long Pointed Burr (Use with 3/8" Plug) (PCC3)	\$59.79
BU716N	7/16" Long Pointed Burr (Use with 1/2" Plug)	\$134.12

Wire Brushes

Ideal for buzzout repair of radials



535-08014 535-15463

Copper Center® Wire Wheel Brushes-Wire Fill

Ascot #	Mfg. #	Dia.	Wire Size	Arbor RPM	Hole	Price
535-15463	15463	2"	.0118"	20,000	1/2"-3/8"	\$9.64
535-15533	15533	3"	.006"	20,000	1/2"	\$14.40
535-15543	15543	3"	.008"	20,000	1/2"	\$12.34
535-15563	15563	3"	.0118"	20,000	1/2"-3/8"	\$11.68

Knotted Brushes

535-08014	08014	3"	.014"	20,000	1/2-3/8"	\$38.42
535-08034	08034	4"	.0118"	20,000	1/2-3/8"	\$39.83

Professional Stitchers

- Corrugated ball bearing stitcher with hardened steel wheel and varnished wooden handle



Ascot No.	Part #	Description	Price
536-00001	30	1-1/2" Diameter x 1/16" Face	\$10.09

Gooseneck Stitchers

The newly designed GOOSENECK STITCHER has been proven to enhance stitching performance, providing ample pressure at all points on the tire without causing muscle fatigue for the tire technician.

Part No.	Description	Price
30GN	1-1/2" x 1/8"	\$9.99
6005GN	2" x 1/4"	\$14.54

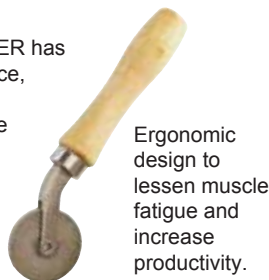

Ergonomic design to lessen muscle fatigue and increase productivity.

Tire Marking Crayons



459-54222



- Bright Color On Any Tire
- Will not melt, soften or rub off in the pocket. A quality crayon that marks on tires, tubes and rubber. Sold 12 per box.

Ascot No.	McGee No.	Color	Price
459-51420	51420	White	\$7.99
459-51422	51421	Yellow	\$7.99

The White Markal Crayon in use.

Channel Lock Cutters

- Precision made of fine polished, high carbon steel
- Distinctive CHANNEL LOCK Blue comfort grips



CHA358 CHA437 CHA447

Ascot #	McGee No.	Description	Price
319-00358	CHA358	8" Cutting plier with end cutter	\$39.27
319-00447	CHA447	7.75" Curved diagonal cutting plier - lap joint	\$38.00
--	CHA337	7" Lap joint diagonal plier	\$33.79

Buffing Wheels



Ascot No.	McGee No.	Description	Price
539-00033	33	3/8" - 24 Arbor for mounting buffing wheels	\$8.65
539-10001	BC1	36 grit, round-nose buffer wheel, Tungsten Carbide 2 1/2" diameter - use on tires or tubes	\$5.58
538-13000	1030G	2" fine tooth buffing cone-Ideal for passenger inner liners	\$16.67
538-01034	1034T	2" med. tooth buffing cone-Ideal for passenger inner liners	\$20.38
539-00788		(2) No. BC-1 buffing wheels mounted back-to-back on No. 33 Arbor (order item separately)	
538-14000	RH140	Faster, cleaner buffing; avoid burning	\$26.48
	TCW21060SAEN	2" x 1" 3/8" SAE 60g rasp cup	\$23.35

RPG Air Powered Tire Repair Vacuum

- Quick change from blow to vacuum function
- KIT INCLUDES: Plastic body gun, dust bag, 2 extension tubes, shop brush, flat tube, tiny tube



\$49.99

BLOW VACUUM FUNCTIONS

Ascot No.	Mfg. No.	Description
537-00003	VGB2	RPG Air Powered Tire Repair Vacuum

Aluminum body Rema version available

Manual Tire Spreader MS1 - 64.99



HD CP Low Speed Buffer CP873HDES (Extended shaft) and CP873HD available!

- Composite material and light weight
- Easy and comfortable to use, reducing constraints for the operator
- The buffing wheel is equipped 7/16" hexagonal quick change slip chuck
- Reinforced streamline & lock-off safety lever
- Heavy duty version : have air swivel inlet for more comfort
- Great for retreading and commercial application



RUBBERHOG TIRE REPAIR

Rubberhog carbides have a coating of randomly spaced sharp uniform conical teeth made from a very hard tungsten

carbide material. It is the combination of the sharpness of the teeth, with the uniform height and shape of the teeth, that gives the Rubberhog rasp a fast, cool, superior buff texture resulting in a longer rasp service life.

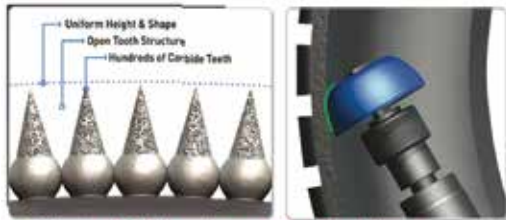

S&S Structured Carbide coatings and unique flared shape maximizes contact, producing a flat, level buffed surface!

Low Speed Tire Buffer with Quick Change Slip Chuck

15810873 - \$86.98

- Brass bushings provide performance and durability in tough working conditions
- Includes whip hose and exhaust hose
- Built in regulator
- Lock off throttle to prevent accidental start ups
- Rear exhaust directs air away from work area
- Quick change slip chuck for fast and easy change of buffing wheel
- Ideal for patchwork, roughing areas for recapping and cleaning tire moldings
- Equivalent to and has same dynamics as the CP 873k
- Overhose kit also available 175-00873



Overhose Kit & Connections



Polyplugs-RH152 2 1/2" is most popular



- Compensates for mounting inaccuracies
- Improves wheel life
- Reduces vibration for smoother, quieter, more comfortable operation.

Don't forget to upgrade your Flared Contour Wheels with PolyPlug Inserts for an even better buffing experience!

2-1/2" All-Purpose Tire Buffing Wheel



- Our most popular wheel
- Covers more tire sizes than any other wheel
- Wide range of applications: Passenger/LT, Medium & Commercial Truck and Retreading

Part #	Diameter	Bore	Coating
RH107	2-1/2"	3/8-24	Fine (170)
RH109	2-1/2"	3/8-24	Medium (230)

1-1/4" High Performance/Low Profile Tire Buffing Wheel



- Buffs inner liner of low-aspect tires without damaging the bead area
- Machined-steel construction for smooth operation
- Internal thread; no exposed threads at top
- Superb control and comfortable use
- Preferred by many for any passenger or light truck repair

Part #	Diameter	Bore	Coating
RH140	1-1/4"	3/8-24	Fine (170)

1/4" Shaft Tool



- Larger spheres, tapers & rotor saw are excellent for high-tread skiving.
- Smaller spheres chamfer around injuries on liner; don't take a chance on entrapped air!
- For section repair or high-tread repairs on radial truck tires & hot repair on nail injuries for retreaders.

Part #	Shape	Diameter	Coating
RH603	Sphere	7/8" (22.2mm)	Coarse (330)

High Speed Tire Buffer Kit with Quick Change Chuck

15811871 - \$69.99

15810871 - with Jacobs - \$69.99

- Lock-off throttle
- Free speed 22,000 RPM
- Includes overhose kit



Ascot #	McGee #	Description	Price
173-09165	2500	Quick Change Chuck	\$22.18
173-09201	2510	1 ¹¹ / ₁₆ " x 3/8"-24 Chuck Adap. w/Washer & Nut	\$4.64
173-09202	2511JD	2 ³ / ₄ " x 3/8"-24 Chuck Adap. w/Nut & Wheel Spacer	\$6.62
173-09211	2512JD	1 ⁷ / ₈ " x 3/8"-24 Threaded Adap. w/Washer & Nut - Quick Change	\$3.91
173-09212	SLP9212	2 ¹ / ₄ " long x 3/8" - 24 Threaded Adap. w/Washer & Nut Quick Change	\$4.64
173-09213	2522	1 ¹⁵ / ₁₆ " Adap. w/Set Screw for 1/8" Shank	\$3.07
173-09215	2523JD	1 ¹⁵ / ₁₆ " Adapter w/Set Screw for 1/4" Shank	\$3.07
173-09216	SLP9216	1 ¹⁵ / ₁₆ " Adapter w/Set Screw for 5/16" Shank	\$3.07
173-09400	SLP9400	Overhose Kit	\$22.18
173-00024	S1047XL	Adapter Quick Change XL Thread 3/8" x 1-3/4"	\$6.39
173-00025	S1047	Adapter Quick Change Long Thread 3/8" x 1"	\$6.49
173-00026	S1046D	Adapter Quick Change Double End	\$8.49
173-00027	S104138	3/8" Quick Change Adapter for 3/8" Burrs	\$9.99

Truck Service Gauges



- Wide variety of service gauges to accommodate the numerous tire and wheel configurations encountered by tire service personnel
- Available in chrome plated or protective black epoxy finish as indicated
- Calibrated from 10-150 psi in 2 pound increments
- Nylon or metal indicator bars

Ascot No.	McGee No.	Gauge Type	Price
476-10135	GA135	Angle Chuck With Nylon Bar	\$8.52
476-11135	GA135S	Same As Above, Angle Chuck With Metal Bar	\$11.16
476-10155	GA155	Straight-On With 30° Reverse Chuck	\$13.99
476-10165	GA165	Same As Above, Straight-On With 30° Reverse Chuck, Black Epoxy Finish	\$10.64
476-11155	GA155S	Same As Above, Straight-On With 30° Reverse Chuck, Metal Bar	\$18.66
476-10185	GA185	Dual Foot Service Gauge With Nylon Bar, 180° Chuck, Chrome Plated	\$10.38
476-01046	7285E	Externally Adjustable Metal Bar Truck Gauge – 10-150 psi	\$15.34

European-Style Clip-On Chucks

Ascot No.	McGee No.	Description	Price
478-02985	CH360	European-Style Clip-On Chuck. 1/4" Female Fitting. Silver Clip. (Normally Closed).	\$9.75
478-02995	CH360OP	European-Style Clip-On Chuck. 1/4" Female Fitting. Black Clip. (Normally Open).	\$13.03
478-01200	N1200	European-Style Clip-On Chuck. Serrated Shank for 1/4" I.D. Hose. Silver. (Normally Open).	\$13.29



Made in the USA

McGee No.	Description	Price
6293DUSA	European-Style Clip-On Chuck, 1/4" Female Fitting. Silver Clip. (Normally Closed). (CH360)	\$9.99
6293EUSA	European-Style Clip-On Chuck. 1/4" Female Fitting. Black Clip. (Normally Open). (CH360OP)	\$9.99

Lock On Air Chucks

Ascot No.	McGee No.	Description	Price
478-05265	5265SH	Lock-On Air Chuck. Specially Designed To Lock Onto The Cap Of A Standard Bore Valve Stem When The Sliding Sleeve Is Pushed To Forward Position	\$11.50



Pocket Truck Gauges



Ascot No.	McGee No.	Description	Price
476-10150	GA150	Straight-On/Angled Gauge. 20-120 psi. Chrome Plated.	\$9.37
476-10160	GA160	Straight-On/Angled Gauge. 10-120 PSI. Black Baked Epoxy Protective Finish.	\$9.99
476-10130	GA130	Dual Foot Angled Pencil Gauge. 20-120 psi.	\$6.40
476-07263	7263USA	Straight-On/Angled Gauge USA Made 20-120 PSI. Black Baked Epoxy Protective Finish	\$11.70

Automotive Tire Gauges



- Pencil, chrome tire gauges with nylon indicator bars

Imprinted Gauges Available with Your Name. Call for details!

Ascot #	McGee #	Range	Type	Price
476-10105	GA105	10-50 PSI	Passenger Gauge	\$3.74
476-10115	GA115	20-120 PSI	High Pressure Gauge	\$3.64
476-10100	GA100	1-20 PSI	Low Pressure Gauge	\$3.38
476-10110	GA110	10-50 PSI	Passenger Gauge 75-340 kPa Calibrated in PSI & kPa	\$3.86
476-10125	GA125	5-45 PSI	Air/Liquid Gauge - tractor	\$3.38
476-10145	GA145	10-75 PSI	Mid-Range Gauge 70-500 kPa Calibrated in PSI & kPa	\$3.04
476-03501	3501	10-100 PSI	Master Tire Gauge & Black Angle Bend	\$9.88

Dual Foot Air Chucks

Ascot No.	McGee No.	Description	Price
478-01350	CH350LO	Straight-On/Angled Chuck. Protective Black Epoxy Finish. (Normally Closed)	\$12.43
478-00335	CH335	Angled Chuck. Plated Finish (Normally Closed)	\$8.40
478-03300	CH330LO	Straight-On/Angled Chuck. With Lock-On Threads (Normally Closed)	\$9.06
478-03301	CH330	Straight-On/Angled Chuck (Normally Closed)	\$7.15
478-03330	CH333LO	Straight-On/Angled Chuck. 14" Long (Normally Closed)	\$11.27



Ball Foot Chucks

Ascot No.	McGee No.	Description	Price
478-00335	5499	Ball Foot Chuck. 1/4" Female Thread (Normally Closed)	\$3.99
478-00315	5567	Ball Foot Chuck With Lock-on Clip. 1/4" Female Thread (Normally Closed)	\$6.99

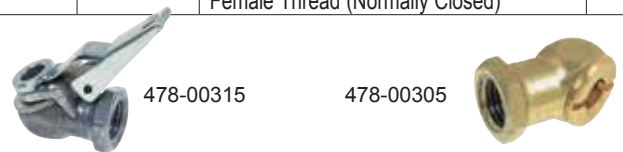

Micro Diamond Nitrile Gloves

- 100 per box
- Texture Finish
- 6 mil Thickness
- Powder Free

Call for current pricing and availability



Ascot No.	McGee No.	Size	Color
396-00302	32806BK240R3	Medium	Black
396-00303	32806BK240R4	Large	Black
396-00304	32806BK240R5	X-Large	Black
396-00402	32806OR240R3	Medium	Orange
396-00403	32806OR240R4	Large	Orange
396-00404	32806OR240R5	X-Large	Orange
396-00803	BLKL	Large	Black
396-00804	BLKXL	XL	Black
396-00805	BLKXXL	XXL	Black

High Visibility Dual Color Leather Double Palm Gloves

Split leather double palm

- High visibility green and orange colors
- Half fleece lining
- 12 pairs per package



396-55223 - \$4.99/pr

RPG Mechanic's Gloves

Black synthetic leather palm with small patches

Features blue spandex on back, neoprene on knuckle, 4cm wide elastic, hook & loop



396-10011 - \$11.45

Gemstone Protective Eyewear - Clear

Y19CFC - \$2.98 pr.



Tinted Available (SG2Smoke)



Cotton Weave Blue Poly Palm Glove

C122 - \$2.49/pr
\$1.59/pr. per doz



Leather Palm Short Cuff

Part #112
\$4.49 pr.



Black, Ultra Light Polyurethane Palm Glove

- Perfect for handling small parts
- Specify M, L, XL



GP180L

Gloves Black Polyester Textured

- CE certified
- Textured latex finish offers excellent grip & superior abrasion resistance
- 13-gauge polyester liner for a flexible fit
- Machine washable



ASBCP - \$19.99 12/pk



Dill - OE - Stem Snap-In Tubeless Tire Valves

Made with special rubber compound to resist ozone damage and prevent premature deterioration caused by rim hole compression, heat, cold. Maximum inflation pressure is 65 P.S.I.

Valve Hole	McGee No.	Effective Length	Standard Pack Box	50 Pk Price
.453	TR412	7/8"	500	\$.35
.453"	TR413	1 1/4"	500	\$.35
.453"	TR414	1 1/2"	500	\$.42
.625"	TR415	1 1/2"	500	\$.48
.453"	TR418	2"	500	\$.50
.453"	TR423	2 1/2"	500	\$.65
.625"	TR425	2"	500	\$.77

Special prices on boxes of 500 each.



413 414 418 423 415 425



Machine Year Month Day

Snap-in tire valves have become a commodity even though they are critical in maintaining the correct tire pressure. As questions arise regarding the life of rubber components and as an effort to provide traceability for this product line, Dill provides a solution! Each Dill stem has the production data etched on it!

Now! Economical Asian stems TR413IV - \$.24 ea. TR418IV - \$.29 ea.

Chrome-Sleeve Snap-in Type Tubeless Tire Valves



- Standard snap-in type tubeless tire valves are fitted with an attractively designed hexagon valve cap and chrome sleeve to cover the valve stem area
- Available in two lengths to fit .453" valve holes.

Ascot No.	Mfg. No.	Eff. Length	Price
461-41211	412SC	7/8"	\$.59 ea
461-41311	413SC	1-1/4"	\$.69 ea
461-41811	418SC	2"	\$.89 ea

High Pressure Snap-In Valves — Dill OE

- Tubeless snap-in type valves for high pressure applications
- Maximum cold inflation pressure is 80 psi
- For .453" or .625" rim holes
- Do not use on tire rims that exceed .205" in thickness



Ascot No.	TR No.	Eff. Length	Valve Hole Dia.	Sale Price
461-00600	TR600HP	1.27"	.453"	\$.83
461-00602	TR602HP	2"	.453"	\$.93
461-00801	TR801HP	1.25"	.625"	\$.99
461-00802	TR802HP	2"	.625"	\$1.37

TR600HP1V import - 100 each - \$39 ea
TR600HPC Chrome Available

1/8" Rim Hole Cleaning Brush

44078 \$6.99

Available in 1/4" and 3/8" also!





Tubeless Truck Clamp-in Valves Dill - with U.S.A. made grommet!

Straight clamp-in valves used on both demountable and non-demountable rims. For .625" diameter valve hole.

McGee #	Effective Length	Cost Each	100 Ea.
TR500	2"	\$1.68	\$1.30
TR501	1 1/2"	\$1.68	\$1.30
TR501IV	1 1/2"	\$1.37	\$1.27
TR570	3 1/8"	\$1.73	\$1.34
TR571	3 3/8"	\$1.77	\$1.44
TR572	3 3/4"	\$1.89	\$1.46
TR572IV	3 3/4"	\$1.29	\$1.23
TR57213	13° bend in valve	\$2.13	—
TR573	4 3/8"	\$1.98	\$1.42
TR573IV		\$1.42	\$1.36
TR57313	13° bend in valve	\$1.98	—
TR573HT13	13° bend in valve high temp	\$2.50	—
TR574	5"	\$2.12	\$1.63
TR575	1-1/8"	\$1.55	\$1.53

IV is Ascot branded product.

Remember - Bending a valve after it is in the wheel will often ruin the grommet and will cause a valve leak.

Metric Rim Hole Valve MS Series

(9.7mm Valve Hole)

468-00707

- Some imported trucks will have steel wheels that incorporate the 9.7mm valve hole (.390")



Recommend installation torque 100 in - lbs

McGee No	Ascot No	ETRTO	Bend	A	B	Price (ea.)
60MS27	462-06027		27°	1-3/16"	1-3/16"	\$3.72
70MS27	462-07025	V3-20-5	27°	1-3/16"	1-9/16"	\$3.74
80MS27	462-08027	V3-20-7	27°	1-3/16"	2"	\$3.76
90MS27	462-09027	V3-20-4	27°	1-3/16"	2-3/8"	\$4.43
115MS27	462-11527	V3-20-6	27°	1-3/16"	3-3/8"	\$4.04
41MS00	462-04100	V3-20-1	STR	1-3/16"	—	\$3.49
70MS7	468-00707	—	7°	—	—	\$3.73

70MS7 - Long thread for thicker wheels on motor coaches

Tubeless Valves for Aluminum Disc Wheels

For drop-center aluminum disc wheels with 5/8" bottom valve hole



Ascot No.	McGee No..	Effective Length	Price ea.
463-00509	TR509	4-3/4" Straight	\$3.16
463-00510	TR510	5-1/2" Straight	\$3.02
463-00511	TR511	4-1/4" Straight	\$3.69
468-05093	TR509-3	Replacement Rubber Grommet	

Ford "F" Series Truck Valve

- Ford "F" series with dual wheels
- Alcoa aluminum 16" wheels
- Front and rear wheels
- Chrome finish
- Dual seal cap included

Ascot No.	McGee No.	Description
462-01600	VS902WP	Ford "F" Series Valve

\$2.99 ea.

Ford "F" Series Truck Valve

- Ford "F" series with dual wheels
- Accuride steel 16" x 6" wheels
- Front and rear wheels
- Nickel finish
- Includes dual seal cap

\$2.79 ea.

Ascot No.	McGee No.	Description
462-02416	TR416MC	Ford "F" Series Valve

23° bend

Core Tools



Ascot No.	McGee No.	Description	Price
469-00612	TL612	Standard Core Tool 8"	\$9.11
469-00021	TL615	Standard Deflator Core Remover	\$1.04
469-00003	5411	Core Tool Screwdriver Handle	\$2.99
469-00005	TL685	Standard and L/B Core Tool	\$1.72
469-00002	4205	4 Way Tool Steel	\$4.95
469-00044	46900044	Core Torque Tool	\$24.99
469-00081	46900081	4 Way Tool - "The Best"	\$5.90
469-00607	TL620	Valve Core Tool Std Bore Screwdriver Type	\$6.99

Valve Stem Ratchet Wrenches



Ascot No.	McGee No.	Description	Price
469-00018	VSW18	For TR570 series valves	\$23.88
469-00020	VSW20	For TR540 & TR550 series valves	\$26.30
168-00058		5/8" Preset Torque Wrench for TR540-550 Series Valve Hex Nuts	\$57.25
168-00916		9/16" Preset Torque Wrench for TR570 Series Valve Hex Nuts	\$57.25
313-00058	58SFHCW	Stubby Flex Head Combi Wrench 5/8" - Ideal for TR540-50 Series	\$19.99
313-00916	916SFHCW	Stubby Flex Head Combi Wrench 9/16" - Ideal for TR570 Series	

Valve Tools

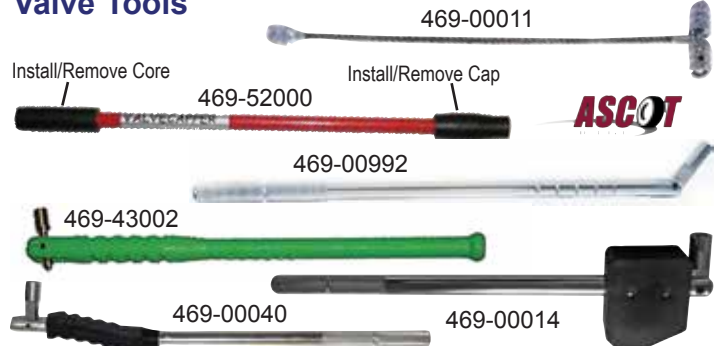

Ascot No.	McGee No.	Description	Price
469-52000	52000	Valvecapper is 11.5" long-designed to reach the inner valve on dual wheel. One end is for the removal/installation of valve caps and the other end is removal/installation of the core	\$18.99
469-00011	TL645	Cable Valve Fishing Tool. Valve core wrench and deflating pin with flexible cable for fishing valve through rim hole. 24"	\$3.30
469-00992	610	Tubeless Tire and Tire Valve Inserting and Removing Tool. For all sizes of snap-in passenger car tire valves	\$9.68
469-43002	43002	Plastic Valve Puller	\$10.95
469-00014	VT014	Install/Remove Removal Tool. Rubber block adds leverage	\$9.95
469-00040		Valve Stem Puller Angled w/Rubber Boot	\$10.99

Double Seal Cap



- Reduce pressure check time by 65%
- Designed for high pressure truck tire service
- Inflate, deflate or gauge directly thru the DS-1 saving time during inflation and pressure checks

Now approved by UPS and Ryder

Visit McGee resource page for details or link at:



Ascot #	McGee #	Description	Price
468-04191	DS1	Double Seal Cap - Haltec	\$.72
468-02222	AE1	Alligator Double Seal Cap	\$.79

5-Gallon Bead Seater

- 5-gallon capacity
- Equipped with a butterfly valve for maximum air discharge
- Designed for commercial use on large truck tires, passenger and ATV tires to 24.5"
- Made in Taiwan
- Parts interchangeable with competitive models



\$179.99

473-01500
5-Gallon Bead Seater

Jet Pak Bead Seater Upgrade Device

- Faster and easier than standard ball or butterfly discharge valve operation
- Discharges tank with the press of a button
- Safety cover prevents accidental trigger release
- Two port sizes available: CH1.5JP (1.5") and CH2.0JP (2") to fit any standard bead seater in a variety of tank sizes
- Attaches easily to existing pipe nipple, replacing manual discharge valve
- Includes our new improved Jet Barrel (VP 3.103 or VP 2.103) for greater air volume delivery • Comfortable handle assures firm grip and ease of use
- All internal components can be removed and serviced if required



Ascot No.	Mfg. No.	Description
473-00020	CH-2.0JP	Jet Pak Bead Seater Upgrade Device - 2" Port Size
473-00015	CH-1.5JP	Jet Pak Bead Seater Upgrade Device - 1.5" Port Size

5-Gallon Cheetah Bead Seater

473-00500 CH5

- Makes seating the most difficult bead safe, simple
- 5-gallon capacity
- Designed for commercial use on large truck tires, passenger and ATV tires to 24.5"
- Fill tank from any service station chuck or service truck air compressor
- Made in Taiwan



\$259.99

Bead Bazooka

- Ultra compact design for fitting in truck cabinets
- More powerful than previous design



GBBVRK repair kit available

Ascot No.	Description	Price
473-00103	3 Liter Cars & SUV Tires	\$309.99
473-00106	6 Liter Car & Commercial Tires	\$349.99
473-00110	10 Liter Car & Commercial Tires	\$459.99

Tire Valves - 540 Series

O-ring seal valves for Alcoa truck wheel (9.7MM Valve Hole)

Many production Alcoa aluminum wheels are manufactured with a 9.77MM valve hole that requires an O-Ring tire valve. Valves have a high temperature resistant O-Ring and a heavy duty metal valve cap.



Valve TR No.	A Height	B Length	C Bend Angle	Price ea.	100 ea.
TR542	1.25			\$2.64	\$1.35
TR543	2.40	-	-	\$2.92	\$1.66
TR543D	.98	1.38	60°	\$3.06	\$1.66
TR543E	.98	1.38	75°	\$2.95	\$1.66
TR544	2.90	-	-	\$3.48	\$1.84
TR544D	.98	1.94	60°	\$3.48	\$1.84
TR545	3.50	-	-	\$3.58	\$1.99
TR545DL	3.50	Dill	--	\$3.99	\$2.38
TR545D	.98	2.6	60°	\$2.07	\$1.86
TR546	4.25	-	-	\$3.50	\$2.07
TR546D	.98	3.35	60°	\$3.93	\$2.07
TR546E	.98	3.35	75°	\$3.97	\$2.07
TR546G	.98	3.35	36°	\$3.65	\$2.96

Metric Clamp-In Valves - 550 Series

Popular on all new Alcoa wheels!

Compatible with aluminum wheel designs with .389 valve hole.

- Viton grommets offer a greater temperature range, a better seal, and a longer service life — Maximum temperature 250°
- Easier installation with screwdriver slot.
- Recommend installation torque 45 in - lbs.

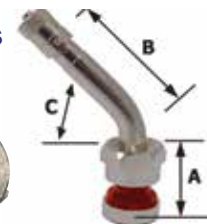

McGee #	A	B	C	Price ea.	100 ea.
TR553	2.31	-	-	\$4.01	\$2.86
TR553C	0.93	1.38	45°	\$4.01	\$2.86
TR553E	.98	1.38	75°	\$4.01	\$2.98
TR554D	.98	1.94	60°	\$4.01	\$2.93
TR555DL	.98	2.6	60°	\$4.01	\$2.04
TR555E	.98	2.6	75°	\$4.01	\$2.36

TR555D import \$1.82 each!

Use TR550 series for better seal than TR540 series

Truck Grommets



McGee #	Rim #	Fits	Used On
5953	RG-15	.625 Valve Hole	TV-500 Series, TV-570 Series
RG15S	RG-15	.625 Valve Hole	TV-500 Series, TV-570 Series red grommet 288°
G160	RG-22	.812 Valve Hole	H-41, T-81, T-30, DS-385, DS210
5093	RG-46	.625 Valve Hole	TV-509, 510, 511
G174	RG-48	.625 Valve Hole	TV-513, 515
G170S		.625 Valve Hole	Heat-Resistant Grommet for TV-570 Series (400°) green
59765	RG-54	.453 Valve Hole	TV-416, 416L, 6008
525	RG-39	.625 Valve Hole	TV-416, 416L
G550	RG-70	.9975 Valve Hole	Fits TV-550 Series - 400°
0330	RG-60		TR-540 Series Valves - 400°



Air-Liquid Core Housing and Accessories

6008B Tractor Front Wheel Valve Low profile tubeless valve offers minimum protrusion above rim hole. Effective length: $\frac{9}{16}$ ". Chrome finish. Fits .625" or .453" rim hole. Standard Pack: 10/box.	\$1.99 ea
468-00203 594TM (TR-CH-3) Core Housing Screws into all valves and extensions shown here. Features O-ring seal. Standard Pack: 10 /box.	\$1.10 ea

Tubeless Type Air-Liquid Valves

These clamp-in valves have a removable 5789 Core Housing to permit fast filling of tires with liquid ballast solution. Fit .625" valve holes.

Ascot No.	McGee No.	TR No.	Straight Length	Price
464-00618	TR618A	618A	1-15/16"	\$2.99

Large Bore Air Chucks



Ascot No.	McGee No.	Description	Price
478-00377	377	Long Lock-On Air Chuck.	\$22.95
478-00322	322	Large Bore Dual Foot Air Chuck. 45° Chuck For Easy Access To Valve. 1/4" NPT Female Thread.	\$37.32
478-04660	H4660A	L/B Clip-on Air Chuck 1/4" NPT	\$24.95
	5260	L/B 8 Piece Tool Kit	\$139.99

Super Large Bore Air-Liquid Valve For Tractor & Grader



464-00216 R372 (CH-16) Fits T81, C-100 & TR SP 816 Tube Spud.	\$6.00
464-00208 T81 (SP-8) Fits 13/16" Dia. Rim Hole.	\$8.99
464-00082 T82 (-) T-82 Clamp-In Rim Spud - 1/4" longer effective length	\$12.99
466-00910 H50 (TR-F-910) Straight Valve Assembly Components T81 Spud and R372 Core Housing.	\$17.99

Single Bend Swivel Valves



- Any other lengths may be ordered
- All valves equipped with core and hex cap
- On lengths over 6", 2 lock nuts are furnished
- Large bore swivel valves can be used with 1441 spud

Ascot No.	McGee No.	TR No.	Bend Angle	Length	Height	Price
465-01418	N1418	-	74°	1-3/4"	1-5/64"	\$13.99
465-00650	WH300J650	J-650	80°	3-1/8"	1-5/64"	\$11.90
465-00653	WH300J653	J-653	80°	2-1/2"	1-5/64"	\$10.90
465-00454	WH454	-	90°	4"	1-5/64"	\$13.80
465-40002	WH45412	J-4000-4-1/2	90°	4-1/2"	1-5/64"	\$10.99

Core Housing

- Complete with core and cap
- Designated at tire and rim as the CH-8
- Integral part of the system as the CH-8 is removed from the valve assembly with the IN-80A adapter to utilize the larger opening and the fullest flow of the 6185 check valve.

Ascot No.	McGee No.	TR No.	Description	Price
466-00918	R520	TR-CH-8	Core Housing	\$14.49



Large Bore Caps and Cores



Ascot No.	McGee No.	Description	Price
465-00145	A145	Large Bore Core (Short) Fits 305-32 threads	\$1.35
465-00148	A148	Screwdriver Valve Cap. Fits .482-26 threads	\$1.65
465-00149	A149	Hex Valve Cap fits .482-26 threads	\$1.32
468-00100	655TM	Adapts large bore down to std. (AD1)	\$2.66
468-08007	656	Same as 655TM but cap style (8807W-3)	\$3.30

Turret Valve for Planetary Gear Wheels



Ascot No.	McGee No.	TR No.	Angle Bend	Offset Inches	Length	Price
465-00690	WH330J690	J-690	2 Bends	9/16"	4-11/16"	\$22.99
465-06911	WH330J691B	J-691	18°	-	8-1/2"	\$33.90
465-00693	WH330J693	J-693	60°	1"	5"	\$24.99
465-00694	WH330J694	J-694	28°	-	3-1/2"	\$27.99

Miscellaneous Valves



465-00670 T670 Loader Tire Valve complete with core, hex cap and "O" ring seal. Thread size is 1-1/16-12. Height is 1-25/32".	\$11.50
465-00702 H41 Tubeless Spud (TR-SP-2) , used with all Large Bore Swivel Valves. Fits 13/16" rim hole. Height is 11/16".	\$4.75
465-06702 H42 Straight Valve (TR-J-670-2) equipped with core and hex cap. Height is 1 1/2".	\$8.99
465-06703 H45 Spud and Valve Complete (TRJ-670-3) Consists of H-41 & H-42. Height is 1 5/8".	\$11.89
465-00710 C10 TR-C-10 Large Bore Screw-In Spud. Screws into 1/2" NPT tapped hole in the rim. Can be replaced without dismantling tire.	\$14.99

Pro Park 8S PP8S



Install available

GOLD CERTIFIED
8,000 LB. CAPACITY
72" Lifting Height

F.O.B. Denver

VERSATILE TOOL FOR AUTO LIFT AND STORAGE NEEDS



Shown: PP8S

Specs	PP8S	PP8P	PP9
Capacity	8,000 lbs.	8,000 lbs.	9,000 lbs.
Lifting Height	72"	86"	85"
Overall Length w/Approach Ramps	207-1/2"	222"	221"
Overall width (with motor)	115	115	131"
Overall width (without motor)	103-1/2"	103-1/2"	121"
Overall Length without Approach Ramps	175-1/2"	190"	197"
Approach Ramps	36-3/4"	37"	36-3/4"
Runway Width	18-1/2"	18-1/2"	20"
Runway Length	166"	180"	188"
Runway Thickness	4-1/2"	5"	4-3/4"
Outside of tire to outside of tire	80-1/2"	80-1/2"	97"
Height of Columns	83"	95-3/4"	97"
Clearance Between Columns	94"	94"	109-1/2"
Clearance Between Runways	38"	38"	39"
Outside Runway to Outside Runway	74-3/4"	75"	79"
Clearance Under Runways	68"	81"	80"
Motor	110 V, 1HP	110 V, 1HP	110 V, 1HP
Shipping Weight	1,820 lbs.	1,920 lbs.	2,350 lbs.

Make sure your lift is Gold Certified!

Direct-Lift's Pro Park series four-post lifts are now ALI Certified. It takes a combination of the design, engineering excellence and quality manufacturing to earn this certification. It is extra assurance for you that your lift meets the highest industry safety and performance standards. Look for the Gold label.



DL9
9,000 LB. CAPACITY

Find the right fit:



Specs	DL9
Capacity	9,000 lbs
Lift Type	Overhead
Overall Height	143" (11'11")
Overall Width	132" (11')
Width Between Columns	109" (9'1")
Max Lift Height*	76" (6'4")
Shipping Weight	1450 lbs
Truck Adapters	Included

- Padded shut off bar
- Powder coat finish
- Adapters and bracket included
- Self-setting locks
- Symmetric 2-post lift with asymmetric arm design

AFF210 3-ton Aluminum Light Weight Jack

- This professional grade service jack combines the strength of steel with the lightweight benefits of an anodized aluminum frame; The polished plunger pistons provide a smooth surface for a longer seal life
- 57 lbs!



AFF210 - \$475.00

Jack Rod \$79.99

Turn any jack into a stand!



See it in action:



8 Gallon Oil Lift Drain

- Reinforced base will not warp with hot oil
- Wide working range from 36.5-74"
- Low center of gravity for increased stability
- 4 swiveling, easy roll wheels
- Heavy adjustment clamp with large handle and large pour threaded spout.
- Built-in strainer with funnel



3-Ton Jack Stands

30263030
\$39.99

More info on page 20

Now with double lock safety pin for added security

CPH001 LED Rechargeable Headlamp \$24.99

- Hands free on/off of main light
- ABS silicone band (lightweight)
- COB high, low, and flashing with 3W Led High/low spot
- USB charging 3-4 hrs with working time 3-8hrs
- Waterproof and shockproof



COB Rechargeable Work Light TWL3007E - \$19.99



Magnetic Swivel Bottom

105D2 CP 1/4" Dr Air Ratchet

\$49.99! While supplies last!

The 105 Series air ratchets are small, durable, and easy to handle for vehicle repair technicians. The low profile forward/reverse control has a wide diameter for easy gripping and increased control in confined spaces.



18241 Blow Gun Deluxe Kit \$35.99

- While supplies last Blow Gun Kit and Air Hose!
- Specially designed hose that has been developed to cater to today's high demand conditions and use
- Stays flexible in the cold and does not kink in the heat
- Full airflow in all weather conditions
- 300 psi working pressure
- 1/4" male fittings
- 3/8" X 32' Air Hose



2V41C60VC compressor

- 5 hp
- 60 gallon
- 230V 1ph

\$1649.99



Tire Bags, Seat Protectors, Steering Wheel Covers, Paper Floor Mats, Parts Bags

Dispensing Racks

Centralize your cleanliness products for the professional image your business needs and the convenience your employees deserve. The top tray holds paper floor mats and elastic band steering wheel covers. Rollers are for seat covers, tire bags, and parts bags.

Order No.	Description	Ship Wt. Lbs.
PSC	Seat Protectors - Roll of 500	20
SWC	Car Steering Wheel Covers - 500 pkg	10
HDTB	Large Tire Bag for SUV - Roll of 250	30
FPFM	Heavy Duty Paper Floor Mat - Box of 500	32
WPB	Parts Bags, 12" x 20" - Roll of 500	15
DR	Dispenser Stand Only	25
41110	Large Tire Bag - Roll of 100	13



#DR



#SWC
500 ea



#PSC



#WPB



250 Bags! - HDTB



#FPFM

Why pay for propellant?

Sure-Shot Sprayer

Great way to dispense brake cleaner and other chemicals. To operate, load liquid and pressurize with air chuck. Easy!

Ascot #	McGee #	Description	Price
632-01002	2000	1 Qt Rust Resistant Black Plated Brass Tank	\$69.99
	KM10	Repair Kit for 2000	\$34.71



M2400S
\$116.99

Brake lathes and parts available

Static Cling Printer

Full feature Reminder Sticker Solution takes professionalism to a new level

- Godex Printer pre-programmed to work out of the box
- 1 year parts and labor warranty (6 months on print head)
- Includes 1 ribbon



399-11111

Static Cling Reminder Stickers

Excellent item to promote repeat business

- Keeps your name, the service to be done and the time to do it in constant view of the customer
- More effective than a door jam sticker
- Static cling vinyl will cling to almost any smooth surface
- No adhesive residue and they can be removed for cleaning and replacing
- Silk screen printing process for a high quality image and a writing strip that won't allow the ink to fade
- Generic design stickers as well as personalized stickers
- RL/500



ORS

McGee Power Scrub

MPS 2.5L Ind Hand Cleaner.

This heavy duty, solvent free, walnut shell based cleaner does it all. It cleans the toughest soils, greases, inks, paints, and almost anything else. Fortified with a new generation emollient package that leaves your hands feeling great. The concentrated one soap that does it all.

Purchase a case of four and get a FREE* dispenser

*Valid for first case \$79.96 purchase



MPS wall dispenser
DSP1JT25

Super Tough Hand Scrub



395-00640 TS64 64 oz. tub **\$17.99**
"The best hand cleaner available"

- Leaves hands soft and chap free.
- Removes dirt and grease quickly.



Now! Tuff Scrub Cleaner in a liquid

TS1GAL

Easy to use pump style - **\$23.95**

GTJ01 - TIRE TRAC Jack leverage tool

- Heavy-duty welded steel construction offers extreme durability
- Steel base roller offers tire support and rolling convenience











GTJ01
\$144.99











GTJ01 -
In Use



Passenger Tape-on Weights Including Cold Weather Weights

	200576FE	.25 oz.	Low Profile Coated	3 oz./strip	48 strips/box	Width: 3/4" Depth: 1/8"	Steel 576 pcs	\$34.89
	200576FER Roll	.25 oz.	Low Profile Coated	Roll		Width: 3/4" Depth: 1/8"	Steel 700 pcs	\$47.89
 Black	200576FEBLK	.25 oz.	Low Profile Premium Tape	3 oz./strip	48 strips/box	Width: 3/4" Depth: 1/8"	Steel 576 Seg/box	\$59.95
	FSF101CP	.25 oz.	Low Profile Economy Tape	3 oz./strip	48 strips/box	Width: 3/4" Depth: 1/8"	Steel 576 pcs	\$29.95
	145KG	.25 oz.	Low Profile Coated Steel	Roll	White Tape	Width: 3/4" Depth: 1/8"	Steel 700 pcs	\$65.95
	320FE	.25 oz.	Premium Coated Steel	Roll	Double Tape	Width: 3/4" Depth: 1/8"	Steel 1272	\$108.30
 Plombco Style	WR31252CW	.25 oz.	Cold Weather Tape	3 oz./strip	52 strips/box	Width: 3/4" Depth: 1/8"	Lead 624 pcs	\$99.95
 Plombco Style	312FE52CW	.25 oz.	Cold Weather Tape	3 oz./strip	52 strips/box	Width: 3/4" Depth: 1/8"	Steel 624 pcs	\$54.69
 Plombco Style	WR41230CW	.50 oz.	Cold Weather Tape	3 oz./strip	30 strips/box	Width: 3/4"	Lead 360 pcs	\$112.67

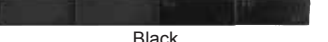
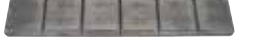
Truck Tape-On Weights

	300360	.50 oz.	Standard Profile Quick Tab with Premium Tape		30 strips/box	Width: 1"	Lead 360 pcs	\$99.95
	300224FE	.50 oz.	Standard Profile Quick Tab with Premium Tape		24 strips/box	Width: 1"	Steel 224 pcs	\$44.16
 Black	300224FE BLK	.50 oz.	Standard Profile Quick Tab with Premium Tape		24 strips/box	Width: 1"	Steel 224 pcs	\$56.95
	420FE	.50 oz.	Standard Profile		Roll	Width: 1"	Steel 640 pcs	\$129.95
	CL6	1 oz.	Standard Profile Quick Tab with Premium Tape		30 strips/box	Width 3/4"	Lead 180 pcs	\$108.71
	1184	1 oz.	Standard Profile with Premium Tape		18 strips	Width 3/4"	Steel 72 pcs	\$39.90
	48410300	1 oz.	Standard Profile with Economy Plastic Tape		36 strips	Width 3/4"	Steel 144 pcs	\$34.99
 Black	48410301	1 oz.	Standard Profile with Economy Plastic Tape		36 strips	Width 3/4"	Steel 144 pcs	\$38.90
	CL12	2 oz.	Standard Profile Quick Tab with Premium Tape		8 strips/box	Width 1-1/4"	Lead 48 pcs	\$64.95
	FSF104C	2 oz.	Standard Profile with Plastic Tape		18 strips	Width 1-1/4"	Steel 54 pcs	\$33.61

Wheel Cleaner

Stop Using Expensive Wheel Cleaning Solutions

Ascot No.	Description	Price
48675032	Wheel Cleaner 32 Oz. Spray Bottle	\$8.75
48675017	Wheel Cleaner 1 Gallon Bottle	\$14.95

A clean wheel is critical to good stick-on wheel weight adhesive.

- Water-Based
- Biodegradable
- Non-Petroleum
- Non-Toxic



A Note About Today's Wheels

For environmental reasons the car manufacturers recently started using water-based paint on wheels. Unfortunately, those paints have an adverse effect on the adherence of wheel weights. The special formulation assures optimal adherence even on surfaces coated with water-based paint.

MC Series fits more U.S. vehicles than any other weight!

"MCN" Series- Wheel Protectors® Coated

The "MCN" series is the recommended weight for all applications shown below. The "MCN" meets all OEM quality specifications.

"MC" Series-Uncoated

Fits most Chrysler, GM, Ford since 1990, Fiat

We recommend that coated weights be used on all vehicles having alloy wheels.

"MCN" Coated—25 pc. box. "MC" Uncoated—50 pc. box

AUDI	LAND ROVER
BMW	MINI
CATERA	MITSUBISHI (see chart)
GEO	SMART CAR
HYUNDAI	SUBARU
JAGUAR	SUZUKI
KIA	VOLVO

AUDI	From 1997
HONDA	
& ACURA	All from 1980 to 1989
MERCEDES	
VW	

Also used on many aftermarket alloy wheels with thin rim flanges

"I7" Series

BTLM = I7

Most popular weight for the medium-duty truck. Used on most trucks with tube type tires. 25 per box except 10 & 12 oz.; 20/box & 14 & 16 oz.; 10/box.

Part. No.	Weight	Part. No.	Weight
I71	1.0 oz.	I78	8.0 oz.
I72	2.0 oz.	I710	10.0 oz.
I73	3.0 oz.	I712	12.0 oz.
I74	4.0 oz.	I714	14.0 oz.
I75	5.0 oz.	I716	16.0 oz.
I76	6.0 oz.		

CT

BTLT + I9 = CT

Used on "section" type, straight flange, tubeless wheels, Goodyear Super Single; Budd 7.50" and 8.25" wheels with Firestone or Goodyear discs. Uncoated.

Part. No.	Weight	Part. No.	Weight
CT2	2.0 oz.	CT10	10.0 oz.
CT3	3.0 oz.	CT12	12.0 oz.
CT4	4.0 oz.	CT14	14.0 oz.
CT6	6.0 oz.	CT16	16.0 oz.
CT8	8.0 oz.		

LEAD, STEEL, AND PLASTEEL WEIGHT OPTIONS AVAILABLE!

Adhesive Wheel Weight Rolls

- Oversized white paper tape - easy peel
- Easy to tear by hand
- Available in grey steel or black steel
- 3 rolls per case
- WWR4 recommended stand for AVL
- Cold weather tape available



Ascot No.	McGee No.	Description	Case Price
484-51500	AVL315FeB	Black Steel Adhesive Roll: 1/4 oz. Segments (2880 Segments per case)	\$152.99
484-51501	AVL315FeS	Grey Steel Adhesive Roll: 1/4 oz. (2880 Segments per case)	\$149.99
484-61500	AVL415FeB	Black Steel Adhesive Roll: 1/2 oz. (1440 Segments per case)	\$152.99
484-61501	AVL415FeS	Grey Steel Adhesive Roll: 1/2 oz. (1440 Segments per case)	\$149.99

MC

ACURA	Most since 1990
DAEWOO	All since 1999
HONDA	All since 1989
INFINITI	All since 1990
ISUZU	All since 1997
LEXUS	All since 1990
MAZDA	Many since 1990
NISSAN	All since 1990
TOYOTA	All since 1990



FN



5 to 70 g

See chart for exceptions



3358HD
486-33581



Scraper 71510
486-071510

486-71510	71510 Adhesive Wheel Weight Super Scraper Removes emblems, body side moldings and stick-on wheel weights.	\$9.90
486-33581	3358 KD Heavy Duty Weight Tool - Ideal for all weights, including coated.	\$28.95

Wheel Weight Adhesive Removal Tool

A143252 - \$69.95

Replacement pad - A1432526 only - \$8.99



- Lock-off trigger for added safety
- High torque motor to cut through stubborn wheel weight adhesive, body pinstripes, etc.
- Rubber-insulated housing for comfort
- High RPM to prevent pad from bogging down; 3,700 RPM free speed

"TS" Series

CHEVROLET GMC - Use on full size pickup, Suburban, Yukon, Tahoe from 2000. Denali & Escalade use MCS for 2000

FORD - Expeditions from 1997 - F-100, F-150 from 1997

LINCOLN - Navigator from 1998

We recommend the use of TS series weights on all full size pickup trucks and vans equipped with steel wheels. The use of "REG" series passenger weights on thicker truck rims may cause over-stressing of clips resulting in weight failures.

Part. No.	Weight	Part. No.	Weight	Part. No.	Weight
TS025	.25 oz	TS175	1.75 oz	TS325	3.25 oz
TS050	.5 oz	TS200	2 oz	TS350	3.5 oz
TS075	.75 oz	TS225	2.25 oz	TS375	3.75 oz
TS100	1 oz	TS250	2.5 oz	TS400	4 oz
TS125	1.25 oz	TS275	2.75 oz	TS450	4.5 oz
TS150	1.5 oz	TS300	3 oz	TS500	5 oz

"TAL" Series Wheel Protectors® Coated Wheel Weights

A new special weight for all Alcoa and Accuride (from 1983) aluminum tubeless heavy truck wheels. The weights will fit both sides of the wheel. These new weights replace the "OS-TAL" and "DS-TAL" series. Use rim gauge RGT2 to verify correct application (either OS-TAL or DS-TAL slot).

"TAL" Coated



Part. No.	Weight	Part. No.	Weight
TAL030	3.0 oz.	TAL060	6.0 oz.
TAL040	4.0 oz.	TAL080	8.0 oz.

Adhesive Wheel Weight Roll Stand

- All-metal construction
- Accommodates three rolls
- Floor mount
- Easy to assemble

486-31281 **\$159.95**
Adhesive Wheel Weight Roll Stand



Ascot No.	McGee No.	Description
486-31281	WWR3	Adhesive Wheel Weight Roll Stand

Eco Balance Drop In Bags!

Eco Balance Beads are made of reusable and recyclable 99.9% tempered glass spheres. Our balancing beads are installed inside the tire, where they won't get knocked off and contaminate the environment like lead weights can.



10 oz. bag **As low as \$6.56**

10 oz. McGee 45101210



Scan QR code or visit www.counteractbalancing.com to find our application charts.



Counteract Balancing Beads

Every bag includes:

- Measured bag of Balancing Beads
- Filtered vortex valve core
- Counteract valve cap
- 8oz bags and up include flow-thru cap.



Counteract Balancing Beads is an easy to use, proven balancing method ensuring you have the smoothest ride possible. One bag of Counteract will keep your tire and complete wheel-end assembly balanced for the life of the tire. Counteracts testing has proven an increase in tire life, reduced maintenance costs, and a proven fuel savings of at least 2.2% with TMC RP-1102 Type II Fuel testing. Simply open the bag and remove the contents, place the clear throw-in bag in the tire and mount the tire. Upon the vehicles motion, the bag will break and the beads will continuously balance the entire wheel-end.

How It Works

The balancing beads will be distributed around the tire as it begins to roll through centrifugal force. As the centrifugal force of the balance (heavy spot) increases and pulls up and down on the suspension, the beads will start to move in the opposite direction of the downward and upward through inertia. The beads continue to travel until the complete wheel assembly is balanced.



Balancing the wheels of transportation



- Easy to use throw-in bag method
- Proven to increase fuel economy
- Color coded application chart
- Life time balance
- Balance whole wheel-end assembly not just tire and wheel
- Can be injected through valve stem
- Proven to extend tire life
- Flow-thru cap provided in 8oz bags and up
- TPMS friendly
- Download app to find tire size

Product	Description - Case Quantity Discounts	CASE QTY
45100013	INJECTOR PUMP FOR COUNTERACT	1
TIB4	4 OZ TOSS-IN BAG	92
TIB6	6 OZ TOSS-IN BAG	64
TIB8	8 OZ TOSS-IN BAG	52
TIB10	10 OZ TOSS IN BAG	40
TIB12	12 OZ TOSS IN BAG	36



IMI FLEXX MORE MILES. LESS FUEL.



FLEXX
MORE MILES. LESS FUEL.

BETTER FOR YOUR SHOP

Fast and Easy Installation

Take an unmounted tire, drop in the new EQUAL FLEXX bag and mount the tire. The bag breaks apart inside the tire for a clean application.



Safer Shop Floors

EQUAL FLEXX is a soft, flexible compound that is not slippery under foot, eliminating any bead-related risk of an accidental slip and fall in your shop.



BETTER BALANCE FOR YOUR CUSTOMERS

EQUAL FLEXX is the only internal, ADAPTIVE wheel-end balancer that can dynamically balance while responding to load, speed, and road forces by distributing weight at the foot-print immediately for the life of the tire.



400SS 4 Ton HD Floor Jack

\$409.99

- Twin hydraulic system for fast and efficient lifting
- Heavy duty pump, ram, and cylinders are precision machined and inspected to ensure long service life
- High grade U-cups seals and high-pressure plunger for maximum performance
- Rear mounted swivel casters for easy maneuverability
- Universal joint technology provides a more controlled descent
- Pinned and padded saddle for extra vehicle protection
- Flanged side plates for increased stability
- Integrated parts tray keeps small components from getting lost



Ask us about our
MOORE SAFE
options

G432020 - Jack Bottle

Air Hyd 20 Ton Gaither \$334.99

- This 20-Ton Capacity jack is one of the toughest in the market
- Each unit comes equipped with an air regulator, a chrome ram and welded base so that it will keep on working no matter the job
- Each unit is hand-tested before shipping to guarantee maximum reliability
- Min Height 10", Max 18.5" EXT Screw 3-1/4"

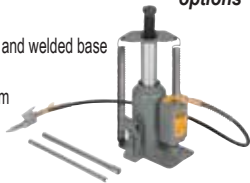

3-1/2 Ton Professional Heavy Duty Double-Pumper Floor Jack

Model 350SS - \$429.99

This unit offers all the features of our model 350GT with additional speed and efficiency thanks to AFF's double-pumper advantage for quicker lifting.

- Lifts from 4" to 19-1/2"
- Pinned steel saddle (1-1/8" stud) with rubber pad for added vehicle protection
- Rear-mounted 2-3/4" swivel casters for ease of maneuverability
- One-piece 50-1/4" padded handle parks upright
- Ship weight 119 lbs.



Replacement Power unit **350SSKHU - \$119.99**

20 Ton Capacity Air/Hydraulic Super Duty Bottle Jack

- AFF's most innovative and robust air/hydraulic bottle jack to date
- Redesigned air motor
- Super thick base to increase stability on every surface
- High-strength Steel Ram and cylinder with long ram guide for greater safety in off-center load conditions
- Welded Tank (threaded and screwed to the base) endures the rigors of in-service conditions and reduces risk of tilting out of the oil reservoir

Low	10.375
High	20.625

Lift	6.375
Base	5.75 x 9

Ship weight 45 lbs.



5620SD	20-ton standard	\$359.99
5621SD	Low profile design	\$349.99
5630SD	30-ton super duty	\$439.99
76320B	20-ton Norco	\$399.99



Jack Oil
HF100
\$8.98 Qt.

*PRICING SUBJECT TO CHANGE DUE TO STEEL SURCHARGES

25-Ton Blackhawk Platinum Air/Hydraulic Jack

- Chrome-plated ram
- Improved bearing surfaces
- High cycle durability
- Long life seals
- High/low temp functionality
- 5 year warranty with electronic registration
- Made in Taiwan

302-00225 **\$899.99**

Ascot No.	McGee No.	Capacity	Min. Height	Max. Height	Saddle Extensions
302-00225	BP225	25 Tons	9-5/32"	22" w/ext.	1", 2.5", 6", & 7"



Bottle Jacks



- Extension screw on some models
- Rust protection covering
- Uniweld construction
- 50% overload factor
- Fewer moving parts

ZN12	Jack Bottle Standard 12-Ton	\$138.99
ZNB22	Jack Bottle Standard 22-Ton	\$219.99
ZNB12	Jack Bottle Low Profile 12 Ton	\$144.16
ZNB22	Jack Bottle Low Profile Screw Out Ext 22 Ton	\$222.40

20-Ton 72090A \$759.99

INTENDED USE: Heavy duty truck, agricultural and heavy construction equipment. Ideal for loaded truck and trailer roadside service calls.

- Its light weight makes it perfect for mobile repair service.
- Long handle with 36-1/2" reach helps in positioning jack under vehicles with low overhang.
- Parkerized coating on pump piston, extension screw and extension adapters and chrome coated ram offer protection against rust.
- Removable extension screw with two 4" extension adapters (included) for added height.
- Self-retracting ram eliminates manual lowering.
- 5 1/4" diameter high impact composite wheels make maneuverability easy.
- Fast efficient air pump reduces lifting time and has a built-in relief mechanism which prevents the jack from being used beyond its maximum allowable capacity.
- Convenient push button air valve connected to an in-line filter prohibits contaminants from entering the air/hydraulic system.



Please call for pricing and availability

Low Lift Height	8.625"	Base Size	9.25" x 17.25"
High Lift Height	22.75"	P.S.I. Range	100-130
Stroke	4.125"	Shipping Weight	63 lbs.
Screw Extension	2"		

22 Ton Air/Hyd Axle Jack with 3pc Ext Kit

New 565F1 from AFF - Now with reinforced frame

Call for availability and pricing

72200D from Norco - \$919.99

565F1 \$699.99

- Specially engineered air motor delivers fast and efficient operation
- Long t-handle design allows easy access to vehicles with long overhangs
- Large 8 inch diameter rubber wheels provide effortless travel in the shop or roadside
- Fully welded hydraulic pump and cylinder delivers maximum strength and leak free operation
- Heavy duty wiper seals protect the system from contaminants and ensures long service life
- Overload safety valve provides added operator safety



Capacity	Ram Lift	Low Height	High Height w/extensions	Length	Front Width	Rear Width
22 tons	4-3/4"	8-1/4"	21-1/2"	20-1/4"	6-15/16"	12-13/16"

Truck Wheel Dolly



BJT300A for 19.5-24.5" Wheels

- Easily handles new super wide tires that are becoming prevalent in the trucking industry.
- Provides technician with the leverage needed to handle the removal and installation of large tires
- Heavy duty tubular steel construction
- Bent handle design improves leverage and reduces user strain
- 14" rollers turn and pivot for accurate & efficient alignment of mounted truck tires with hub stud
- 26" wide carriage handles tire diameters 36"- 48"; 450 lb. capacity

Ascot No.	McGee No.	Description	Price
407-70130	AFF3591	Truck	\$135.99

Ask us about our no mar jack options!

Replacement
Parts
Available

20-Ton Air/Hydraulic Bottle Jacks

- Thick jack base provides exceptional support and stability in severe conditions
- Quick-connect feature on air valve allows easy disconnect and connection of air hose & more compact storage

22-Ton Air/Hydraulic Truck Jack

- Large air motor provides an exceptional quick lifting experience
- Narrow chassis fits between tandem truck wheels
- Comes with three adapters in different sizes that cater to different working requirements



Floor Jacks

- Double pump design for quick lifting and improved efficiency
- Heavy steel construction for maximum durability
- Equipped with a foot pedal to allow for hands free positioning
- 2-Ton, 2-1/2-Ton, 3-Ton, 3-1/2-Ton & 4-Ton capacity



1 Year Warranty
on Ascot Jacks

Ascot No.	McGee No.	Description	Min. Hgt.	Max. Hgt..	Hyd. Lift Range	Exten. Screw	Chassis Size	Saddle Size	Handle Length	Ship Wt. (LBS)	Price
301-20221	AS2022S	20-Ton Short Air/Hydraulic Bottle Jack	7"	12-5/8"	3-3/8"	2-3/9"	N/A	N/A	9-3/8"	30.6	\$249.99
302-19150	AS1915	22-Ton Air/Hydraulic Truck Jack	10-1/2"	21-1/8"	6-1/8"	4-1/2"	N/A	N/A	45-1/4"	101.9	\$479.23
302-05605	AS5605	Ascot 3-1/2-Ton Floor Jack	3-3/4"	20-1/2"	16-3/4"	N/A	27.2" x 14.25"	4-1/4"	47-7/8"	100	\$289.99
302-05614	AS5614	Ascot 4-Ton Floor Jack	4-3/8"	20-1/4"	16"	N/A	27.7" x 14.4"	4-1/4"	47-7/8"	102.5	\$379.99

30251005 10-Ton High Jack Stands (pair)

- Pin-style stands with supporting range from 27.95" to 47.56" suitable for high-height applications
- HD tubular steel design provides stability and rigidity
- Multiple pin holes to allow easy adjustments
- Saddle with lugs for easy positioning of the load

\$399.99



3-Ton Jack Stands

- Ratchet height adjustment built within column
- Multi-level ductile iron ratchet bar adds strength and durability
- Sold in set of two

3-Ton – 30263030 **\$39.99**

6-Ton – 30263060 **\$79.99**



Universal Handle Protector - GHP01 **\$11.99**

Made of a durable synthetic rubber

- Unique design ensures a tight fit on jack/tool handle without slippage
- Protects vehicles from scratches or dents caused by falling jack handles and unstable tools in the shop
- Keeps water/debris out of handle



22-Ton Jack Stands

- Sturdy, welded steel construction for exceptional safety and strength
- Heavy gauge steel helps prevent distortion or twisting
- Multi-position column bar for convenient height adjustment
- Sold in set of two

30263220 **\$259.99**



Accessories for Ascot Grey Service Jacks



Ascot No.	Mfg. No.	Description	Applicable Models
302-60129	AS5601-29-a-FH	Spring	2-Ton/3-Ton/4-Ton
302-61301	AS5613-01	Fixed Wheel Assy.	3-Ton
302-61401	AS5614-01	Seal Kit for Pump	3-Ton/4-Ton
302-61402	AS5614-02	Fixed Wheel Assy.	4-Ton
302-61403	AS5614-03	Pump	3-Ton/4-Ton
302-61404	AS5614-04	Caster	4-Ton

Why Use Jack Stands?

- OSHA Regulation – 1910.244(a)(2)(iii) mandates that once a load is elevated, it must be immediately stabilized with cribbing, blocking, or other securing methods.
- Using a stand merely as a backup beneath the axle or frame in case the jack gives way isn't the right application of the stand.
- Jack stands aren't built to handle abrupt or sudden weights.
- Jacks aren't intended to sustain a vehicle's weight for prolonged periods.
- During maintenance, it's imperative to utilize jack stands to bear the entire weight of vehicles.

2-Ton Service Jack

- True "low-profile" design with deep reach and minimum 2.75" height for low clearance vehicles
- Universal joint mechanism
- Foam handle for vehicle protection
- Industrial grade casters for easy transport
- Safety bypass system for cylinder protection
- 24" max height for increased work space

30262021 **\$299.99**

Low profile design!



ASK US ABOUT OUR
TRANSMISSION AND UNDER
HOIST JACKS TODAY!

1-800-525-8888

286922HD - IMPACT WRENCH SD EXT ANVIL CORDLESS 1" DR \$1,299.99*

- POWERSTATTM Brushless Motor delivers up to 2,000 ft.-lbs of nut-busting torque & 1,900 ft.-lbs of fastening torque
- Install up to 200 1-1/4" bolts on a single battery
- M18TM REDLITHIUMTM Battery Packs are compatible with all M18TM tools
- The ONE-KEYTM Technology allows you to customize, track, and manage the impact wrench with the ability to set a repeatable torque output for maximum control
- Kit Includes:
 - M18 FUELTM 1" D-Handle High Torque Impact Wrench w/ ONE-KEYTM (2868-20)
 - M18 REDLITHIUMTM HIGH OUTPUTTM HD12.0 Battery Pack (48-11-1812)
 - M18TM & M12TM Rapid Charger (48-59-1808)
 - Contractor Bag



276922 - IMPACT WRENCH SD 2" EXTD ANVIL CORDLESS 1/2" DR \$579.99 *

- 4CUSTOMIZABLE MODES: Provides multiple fastening torque outputs designed for sedans, light trucks and box trucks
- POWERSTATTM BRUSHLESS MOTOR: Delivers up to 750 ft./lb. of fastening torque & 1,100 ft./lb. of nut-busting torque
- LONGMOTORLIFE: POWERSTATTM Brushless Motor delivers maximum power and long motor life
- Includes extra battery, case and charger.



With FREE 1/2" drill driver while supplies last.

**All prices subject to change.*

*Stubby and bare tool available as well.

Protect your investment with a boot. Ask your rep for the right size.



1" Heavy Duty Air Impact Wrench

- Combines exceptional power, durability, and operator convenience
- Delivers 1450 ft./lbs. of maximum torque, with a 5000 RPM free speed and four-position power regulator 360° swivel inlet
- Available in 6" extended anvil and 6" extended #5 spline drive anvil for high production truck tire changing



155-02856

Ascot No.	McGee No.	Description	Price
155-28560	IR285B	Standard Anvil	\$739.99
155-02856	IR285B6	6" Extended Anvil	\$649.99
156-28566	IR285BS6	#5 Spline Super Duty Anvil	\$779.99

3/4" Maximum Power Impact Air Wrench

- 3/4" Maximum Power Impact Air Wrench
- 1350 ft./lbs. maximum reverse torque from a tool that weighs just 7.4 lbs. and is compact enough to access tight spaces
- Built to last and designed to withstand tough use in rugged environments
- An air motor that's 16% more efficient than its predecessor and an easy-to-clean inlet screen means less down time, better tool performance, and less money spent on compressed air
- Torque Range: 200-900 ft./lbs.



Ascot No.	McGee No.	Description	Price
154-12145	2145QiMAX	Standard Anvil	\$589.99
154-22145	2145QiMAX3	3" Extended Anvil	\$679.99
154-32145	2145QiMax6	6" Extended Anvil	\$729.99
154-00261	IR261	HD 3/4" SD Wrench 1100 Ft/Lb Torq	\$549.88
154-02616	2616	3/4" Super Duty Air Impact w/6" Ext. Anvil	\$579.99

CP7748TL2 Torque Limited 1/2" Drive



- Limited 1/2" Drive
- "Best Practice Tool" bubble on side
- The CP7748TL series is intended to be used as a "snugging" tool prior to final tightening with a calibrated torque wrench to reach the specified torque rating
- Torque limited in forward: 60/70 ft. Lbs. - 90/100 Nm, Full in reverse
- Insulation & Comfort: Contoured comfort grip handle instead of TPR injected in handle
- Low sound level suited for all light vehicle tire changing applications
- 360° swivel air inlet



BLOWOUT SPECIAL!

ASCOT	MCGEE NO.	PRICE
153-77483	CP7748TL2	\$185.99 while they last!

1/2" CP77482 - Extreme Torque & Durability

- Most powerful 1/2" air wrench in its class
- Twin hammer grease clutch
- Ergonomic rubber handle
- Reinforced nose wings and back housing cap for longer durability
- Max Torque 1200 ft. lbs.
- 922 ft. lbs. Working Torque



CP77482
\$209.99

CP77412

\$159.99

- 10,000 RPM free speed
- 715 Ft/lbs max torque
- Super durable but 15% lighter than CP77362



1" Heavy Duty Air Impact Wrench

2140 ft.lbs 2900 Nm of maximum torque in reverse

- Pinless closed reinforced rocking dog impact mechanism
- Socket retainer ring combined with hole retainer
- Ergonomic side handle
- Full teasing trigger
- Regulator with integrated forward/reverse with 3-position power settings in both directions



155-77826
1" Heavy Duty Air Impact Wrench

ASCOT NO.	McGEE NO.	PRICE
155-77826	CP77826	\$649.99
155-17782	CP7782SP6	\$699.99
	CP77786	\$749.99

CP77786 \$749.99

- The Classic CP77786 for HD applications
- integrated forward/reverse 3-position power settings regulator and directional control.



CP77786

153-02312 IR Ingersoll Rand. 231XP2 with free air hose, while supplies last

1/2" Super Duty Extended Anvil Air Impact Wrench

This new model redefines the standards set by the classic IR231 model, with an enhanced Twin Hammer impact mechanism for more power and in-handle exhaust to direct air away from the operator and the work area.



2235TIMAX2

Ascot No.	McGee No.	Description	Price
153-00231	IR231	Air Wrench 1/2" Dr Short Anvil	\$159.99
	2235TIMAX2	Air Wrench 1/2" Long Anvil Titanium	\$379.99
	2235QTIMAX2	1/2" Dr Quiet Air Wrench Long Anvil	\$389.99
	2235TIMAX	Air Wrench 1/2" Dr Short Anvil Titanium	\$374.99

Kilfroast

Winter is here!

K16 Kilfroast Pneumatic Tool

Anti-Freeze Lubricant, 16 Oz. bottle - 18184581 - **\$9.99**

- Prevents the freezing of pneumatic equipment caused by the formation of ice in and around exhaust ports and valves. Kilfroast absorbs the water in the airline. Is a semi-synthetic lubricant which has none of the drawbacks associated with normal oils.





JB04Blue
\$8.95



175-10029
Set of 6 Rotor Blades

175-13457
Hammer Tune-Up Kit

Marvel Air Tool Oil

085 Marvel Air Tool Oil 32 Oz
18100085 - **\$8.99**

- Prevents rust formation while providing positive lubrication for smooth starting and long tool life
- Assures maximum performance by dissolving gum and sludge that cut down tool speed and reduce power output



085

8 oz. MM80R Available

Blaster 16ATC - Air Tool Conditioner

- Restores & prolongs tool life - 11 oz.
- Provides a coating & lubrication for tools while in use
- Inhibits rust, increases RPMGS for normal maintenance

16ATC
181-00404



\$7.99
(Case price available)

Super Red Pneumatic Air Tool Lubricant

- Dissolves gum and & varnish formation
- Ensures smoother starts
- Special rust & oxidation inhibitor
- Clean and free running
- 12 bottles per case
- Usable on piston or rotary type air tools



Ascot #	McGee #	Price
181-00406	0406	\$7.99

- 6" extended anvil
- 3-position forward and reverse
- High efficiency 6-vane motor
- Pinless clutch mechanism
- Swoop back side handle for maneuverability/balance
- Working Torque 1,800-2,000
- Free Speed 5,000 RPM



Ascot No	McGee No	Description	Price
155-12856	A2856	1" Drive Super Duty Impact	\$399.99



Video on proper air tool maintenance; make your tools last!
(También en español)

<http://vimeo.com/212944966/>



6" EXTENDED ANVIL

1" Drive Super Duty Impact Wrench

\$409.99!



155-17786

Heavy Duty & High Torque!

- DURABLE: Steel end plates offering durability and extended life
- ADVANCED DESIGN: Proven motor and hammer technology; highly efficient air motor
- WORKING TORQUE RANGE: 370-1475 ft./lbs.
- 1 YEAR LIMITED WARRANTY on parts and workmanship
- COMPARE to CP77826

1" Drive Mini Air Impact Wrench

- 6" Extended Anvil
- Free speed: 5000 RPM
- Maximum torque: 2000 ft/lbs
- Only 20 lbs - 50% less than the market leading 1" product, smallest and lightest 1" in the tire service industry
- Twin hammer clutch



155-26464

\$539.99

Ascot No.	McGee No.	Description
155-26464	15526464	1" Drive Mini Air Impact Wrench - 6" Extended Anvil

1/2" Drive Super Duty Air Impact Wrench

- 2" extended anvil
- Handle exhaust
- Free speed: 8000 RPM
- Maximum torque: 600 ft./lbs.
- Proven design and the most popular configuration in the tire service industry
- Powered by the durable and high performing twin hammer mechanism
- Net weight: 5.6 lbs.

\$129.99



153-23120

Protect your investment with bootie JB04BLUE.

Ascot No.	McGee No.	Description
153-23120	A2312	1/2" Drive Air Impact Wrench - 2" Extended Anvil

1/2" Drive Composite Impact Wrench

- Convenient one-hand operated forward/reverse push button
- Four-setting torque adjustment switch
- 685 ft./lbs., 8000 RPM, 4.2 lbs
- Twin hammer mechanism provides smooth balance
- Energy efficient motor for maximum performance with precise speed control
- Swivel air inlet prevents hose from twisting

Now with forward/reverse button!



153-12260

Ascot No.	McGee No.	Description	Price
153-12260	A21312COM	1/2" Drive Composite Impact Wrench 2" Extended Anvil	\$149.99

MA2312G

- McGee 1/2" Drive rubber grip 2" extended anvil impact wrench.
- 8,000 RPM
- 600 ft/lbs torque
- Twin handle mechanism



\$109.95



ALIGNMENT SOLUTIONS

Tandem Truck Shims



36000

\$679.99

Tandem Alignment Set A great starter set!

These alignment angle shims are available in a heavy-duty metal box to help you organize all of your shims. Packaged with a large variety of shims (listed below and on pages 142 and 144) and an organization chart inside the lid to make reordering and organization of shims quick and easy. Don't be caught without the shim you need while you have the tractor in your shop!



Part #	Application	Qty	Part #	Application	Qty	Part #	Application	Qty
35001	Kenworth Airglide space 1/32"	6	35010	Peterbilt Air Leaf Shim 1/32"	6	35061	Freightliner Airliner Susp 1/16"	6
35002	Kenworth Airglide space 1/16"	6	35011	Peterbilt Air Leaf Shim 1/16"	6	35062	Freightliner Airliner Susp 1/8"	6
35003	Kenworth Airglide space 1/8"	6	35012	Peterbilt Air Leaf Shim 1/8"	6	36020	Navistar Corp. 6x4 Air Susp. 1/32"	6
35004	Kenworth Airglide space 1/4"	6	35040	Navistar IHC Torque Arm 1/32"	6	36021	Navistar Corp. 6x4 Air Susp. 1/16"	6
35005	Kenworth Airglide space 1/2"	6	35041	Navistar IHC Torque Arm 1/16"	6	36022	Navistar Corp. 6x4 Air Susp. 1/32"	6
35006	Kenworth Airglide space 3/4"	6	35042	Navistar IHC Torque Arm 1/8"	6	36087	Hendrickson Rear Tandem Walking Beam	10
35007	Kenworth Airglide space 1"	6	35060	Freightliner Airliner Susp 1/32"	6			

Truck Axle Shims

As Low as \$7.29 each

Ordering one Part# supplies **SIX SHIMS** in a box. When placing order spring pad length and width is needed.

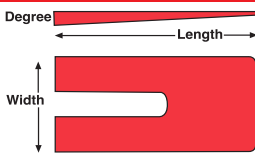

	COST	COMPRESSION STRENGTH	HARDNESS
ALUMINUM ALLOY	\$\$	★★★	★★★
ZINC ALLOY	\$\$\$	★★★★	★★★★★
MANGANESE BRONZE ALLOY	\$\$\$\$\$	★★★★★	★★★★★

Specialty Products carries Truck Axle Caster Shims in three different alloys, giving the technician the opportunity to match price point and mechanical requirements to meet their customer's needs. **Choose from Aluminum, ZINC and Manganese Bronze Shims.**

Truck Axle Shims

ALUMINUM ALLOY HD SHIMS These economical over-the-road heavy duty truck axle shims are our lowest cost option. With average compression strength and hardness these shims are available in a large variety of sizes and offer the technician a cost effective means to correct caster on over-the-road trucks and trailers.

ZINC ALLOY HD SHIMS These over-the-road heavy duty truck axle shims are a fast and accurate means to align front or rear axles of most popular tandem trailers and trucks. Specialty Products' new Zinc Alloy shims offer another level of performance versus our traditional aluminum shims. For a small cost increase versus aluminum, you now have the hardness of our premium manganese bronze shims and a much improved compression strength as compared to aluminum shims.

MANGANESE BRONZE HD SHIMS These shims are the standard. Top of the line compression strength and hardness means that when you set your alignment - it doesn't change.

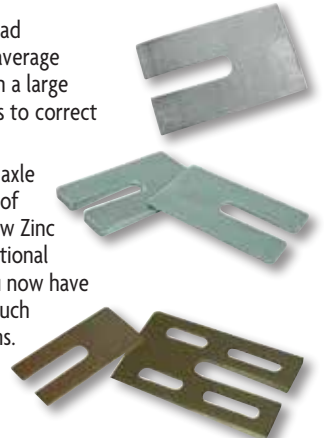

For sizes and more information go to: www.specprod.com/truckaxleshims

89199-89899

ZINC TRUCK AXLE SHIMS

Twice the coverage - half the inventory. Changes caster positive or negative from 1/2" to 4". APPLICATIONS: Any solid axle 2WD or 4WD vehicle. Note: Shims should not be stacked.



Part #	Width	Degree	Qty	Part #	Width	Degree	Qty
89199	3" - 3-1/2"	4 1/2°	6	89799	3" - 3-1/2"	4 3-1/2°	6
89299	3" - 3-1/2"	4 1°	6	89899	3" - 3-1/2"	4 4°	6
89399	3" - 3-1/2"	4 1-1/2°	6				
89499	3" - 3-1/2"	4 2°	6				
89599	3" - 3-1/2"	4 2-1/2°	6				
89699	3" - 3-1/2"	4 3°	6				

As Low As \$71.99 FOR 6

FasTrax™

36087 HENDRICKSON HD SHIMS

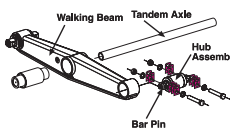

This shim kit will adjust the thrust angle on Hendrickson's 'walking beam' rear tandem axle suspension. Improve tire wear and handling by adjusting thrust angle from 0" to 3/8" in precise 1/32" increments.

REPLACES these OE kits- Euclid Nos: E-9327, E-9328, E-9329

Hendrickson Nos: 50130-000, 50131-000, 50132-000

Adj. Range: 3/8" Required: 1 set per wheel Includes: 2 (two)-five piece kits



\$25.99

NS9142 - WHEEL STUD SERVICE KIT \$349.99

- Works on most hubs for installation and removal.
- All sizes of studs.
- Installation done by pushing on the head, eliminating the need for threaded adapters
- Increases ease of use
- Remove and install 10 studs in only 10-15 minutes (compare to 20-30 minutes for more expensive competitive products)
- Can be powered with an impact wrench, no hydraulic power source required.
- No need to remove hub from vehicle.



493-91420



492-10134

492-10158

Ascot No.	Mfg. No.	Description
493-91420	NS9142	Wheel Stud Service Kit

Nut Loosener Penetrating Blaster - 16PB

A penetrating lubricant that frees everything! Displace moisture by saturating troubled area and allow to stand for a few minutes. 12.2 oz. spray.



\$16.99 ea.

#606 Oil Can \$14.99

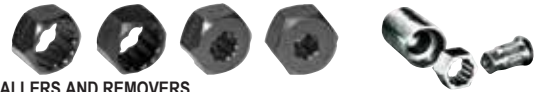

STUD INSTALLERS AND REMOVERS

Ascot No.	Mfg. No.	Description
492-10134	X10-S134Z	3/4" - 10 Stud Installer
492-10158	X10-S158Z	5/8" - 11 Stud Installer
492-10180	2415	1-1/8" (13/16") Stud Remover
492-10340	X10-SR34B	3/4" Stud Remover
492-15000	X10-NR15B	1-1/2" Hex Nut Remover Kit - 3-Piece Kit

REPLACEMENT RIB NUTS

499-10180	X10-LN18B	1-1/8" (13/16") Rib Nut
499-10341	X10-LN34B	3/4" Rib Nut

HEAVY DUTY DRIVE-ON RIB-GRIP LUG-OFF KITS

499-10200	X10-LT20B	For Removing Damaged Inner Cap Nuts (1-1/8" Diam., 13/16" Square Head). Consists of 1 Drive-On Tool and 1 Rib Nut
499-10340	X10-LT34B	For Removing Damaged 3/4" Lug Studs. Consists of 1 Drive-On Tool and 1 Rib Nut
499-10660	X10-LT66B	Triple Duty Tool for Removing Damaged Budd Wheel Inner Cap Nuts, 3/4" and 5/8" Lug Studs. Consists of 1 Drive-On Tool and 3 Rib Nuts

3-Piece Twist Socket Lug Nut Removal System

- Removal of damaged 3/4" and 19mm, 13/16" and 21mm lug nuts
- Two dual-sided twist sockets have a fluted design which gives the sockets a tight grip to remove the most difficult locking and damaged lug nuts from the socket
- Works with 1/2" impact gun or breaker bar for service calls
- Includes an extrator punch



\$59.99



1/8 - 16 Outer Cap Nut 891RZ/892LZ



995LZ/RZ 3/4 - 16 Super Single Cap Nut



269Z Flange Wheel Nuts



881M/333B Free Spinning Flange Nut 2203/2304



3/4 - 16 Outer Cap Nut 888RZ/889LZ



336RZ/337LZ - 13/16 sq. Inner Nut for Steel/Aluminum Combination Longer Version - 621RY/622LY



708RZ/709LZ Grade 8.2 Inner Nut-Aluminum Wheels



988RZ/LZ - 13/16 sq. Inner Cap Nut-Dual Aluminum Wheels

BULK DISCOUNTS AVAILABLE!

McGee No.	Mfg. No.	Similar To:	Sale Price
891RZ (RH)	GL-2001	Budd-37891/2	Euclid-5552-R/L \$1.10
892LZ (LH)	GL-2002	Nuturn-W-13/14	Batco-13-3012-R/L \$1.10
888RZ (RH)	GL-2101	Budd-37888/9	Euclid-5652-R/L \$1.88
889LZ (LH)	GL-2102	Nuturn-W-15/16	Batco-13-3013-R/L \$1.88
995LZ (LH)	GL-2103	Alcoa-5554	Euclid-5554-R/L \$5.48
995RZ (RH)	GL-2104	Budd-70613/4	\$5.48
269Z	GL-2202	GMC-3771410	\$3.59
881M	GL-2302	(1 1/2 Hex) M.W. 88881	\$4.38
333B	GL-2301	(1 1/4 Hex) Budd 106333	\$2.38
Metric Outer Nuts			
GL2009	GL-2009	Hino-9004-21112	Isuzu-1-4233-023 \$5.35
GL2010	GL-2010	(Inner Thread = M30-1.5) \$5.35	

McGee No.	Mfg. No.	Similar To:	Sale Price
336RZ (RH)	GL-1003	Budd-35336/7	Euclid-5735 R/L \$3.25
337LZ (LH)	GL-1004	Nuturn-W107/108	Batco-13-3007-R/L \$3.25
621RY (RH)	GL-1005	Budd-22621/2	Euclid-5568 R/L \$3.66
622LY (LH)	GL-1006	Nuturn-W105/106	Batco-13-3006-R/L \$3.66
988RZ (RH)	GL-1011	Alcoa-5988-R/L	Nuturn-W-486/7 \$3.99
988LZ (LH)	GL-1012	Euclid - 5988-R/L	Batco 13-3026-R/L \$3.99
Grade 8.2			
708RZ (RH)	GL-1001	Euclid-7895R/L	Budd-10708/9 \$1.90
709LZ (LH)	GL-1002	BWP-M128/9	Batco-13-3032R/L \$1.90
Metric			
GL1009 (RH)	GL-1009	Hino-9004-23101	Isuzu-1-42335-005 \$7.50
GL1010 (LH)	GL-1010	(M20 Inner & M30 Outer Threads) \$7.50	

Hub-Centric Wheel Nuts

Extended threading allowing Skirt Nut to go down into Hub-Piloted Disc Wheel an extra 3/16" (5mm) into stud hole



Ascot No.	Mfg. No.	Description	Price
491-02906	GL-2906 333SN6	Haltec 6mm Sleeve Nut • Steel Steers	\$10.49
491-02919	GL-2919 333SN19	Haltec 19mm Sleeve Nut • Aluminum Steers • Steel/Steel Drives • Steel Outer/Aluminum Inner Drives	\$10.49
491-02928	GL-2928 333SN28	Haltec 28mm Sleeve Nut • HD Aluminum • Super Single • Wide Base • Aluminum Outer/Steel Inner Drives	\$13.49
491-02939	GL-2939 333SN39	Haltec 39mm Sleeve Nut • Dual Aluminum Drive Axle	\$10.49

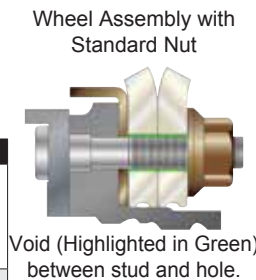

Void (Highlighted in Green) between stud and hole.

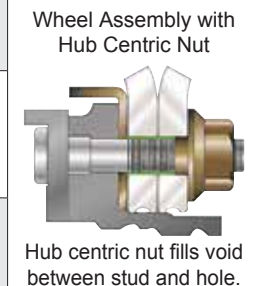

Hub centric nut fills void between stud and hole.

Ascot No.	Description	Price
491-00133	33mm Hex X 1.5mm Thread Made in USA Two Piece Elongated Neck	\$12.99
491-01133	33mm Hex Nut Replaces Standard Nuts on 11.25" Hub Piloted Wheels	\$9.49

By filling the void between the stud hole, "clocking" is eliminated, and problems caused by clocking, such as wheel offs and wheel hub vibrations, are eliminated.

- Stops rim from shifting forwards or backwards
- Eliminates "clocking" caused by standard wheel nuts not filling wheel hole completely

Split-Beam Click Torque Wrenches



- Extremely accurate: within 4% of reading from 20% of full scale to full scale
- Setting torque on adjustable wrenches is fast and easy because there is no spring tension on the adjustment knob
- Torque setting locks on adjustable wrenches for repetitive applications
- Wrench length designed to provide the leverage required for maximum torque applications. Also provides the needed reach for those hard to get at places.



EXTREMELY ACCURATE



Ascot No.	Part No.	Description	Ft./Lbs.	Price
168-03250	C3FR250F	1/2" Drive	250	\$254.99
168-05600	C5D600F	1" Drive	600	\$589.99

Flex Hinge Torque Wrench

- 168-60011 (600FHTW)
- Robust construction
- Accurate results +/- 4%
- Adjustable torque settings
- Dual scaled, Ft./Lbs. & N.m.
- Durable storage case
- Every wrench is supplied with calibration certificate
- 2 adapters included: 3/4" to 1"; 3/4 to 3/4"
- Similar to Norbar 12007 & 12007.01



\$399.95

168-60012 2-Piece Version Available



Made in Taiwan

Heavy Duty Truck Torque Wrench

168-12017 4AR1- \$579.99



- Robust construction gives accurate results to +/-4% even in arduous work conditions
- Supplied with a calibration certificate
- Break back action gives an unmistakable signal
- Break angle improves accuracy by reducing the possibility of overtorquing
- Dual scaled, Nm and ft./lbs.
- New handle - more comfortable and guides operator's hand to correct position
- Now split for ease of transportation and storage

169-03013 - 1" Female x 13" Socket Extension!

03013 - \$59.99

Micro-Adjustable Torque Wrench

Now! \$199.99

- Dual scale, calibrated dual direction
- Positive lock with spring loaded pull down lock ring
- Fast, accurate and easy to set
- Easy-to-read laser marked scale
- Ergonomic comfort-grip
- Most feature quick release buttons which provide good socket retention as well as easy socket removal
- Range: 50-250 ft./lbs.
- Accuracy: ± 4% clockwise ± 6% CCW of indicated value, CW, from 20% to 100% of full scale

DUAL SCALE



Ascot No.	Description
168-12250	1/2" Drive Micro-Adjustable Torque Wrench

CALIBRATED DUAL DIRECTION

319-00777 Mini Ductor Venom



MM99660

See them in action



Ascot No.	Mfg. No.	Description	Kit Contains	Cost
319-00777	MDV-777	Mini Ductor® Venom® - 110V	• 3 Basic Coils: (1) 7/8" Pre-Formed Coil, (1) 23" U-Form Coil, (1) 41" Bearing Buddy Coil • Rugged Plastic Carrying Case • Operator Manual • 2-year Manufacturer's Warranty	\$539.99
319-00787	MDV-787	Mini Ductor® Venom® HP - 120V	• 3 Basic Coils: (1) 7/8" Pre-Formed Coil, (1) 23" U-Form Coil, (1) 41" Bearing Buddy Coil • Rugged Plastic Carrying Case • Operator Manual • 2-year Manufacturer's Warranty	\$599.99
319-99660	MM99-660	Essential Coil Kit for Mini Ductor®	• Two 7/8" pre-formed coils (MD99-601: 5"L x 1.25"W) • Two 3/4" pre-formed coils (MD99-611: 4.5"L x 1.25"W) • One 7/8" long pre-formed coil (MD99-605: 9.5"L x 1.25"W) • One 1" pre-formed coil (MD99-610: 8.25"L x 1.75"W) • One 7/8" long pre-formed coil (LCK) (MD99-621: 13.25"L x 1.25"W) • One 1" long pre-formed coil (MD99-622: 13.25"L x 1.75"W)	

8000 ADB22X Complete Bendex® Air Disc Brake Tool Kit \$1,899.99

- These kits provide specialized tools for the replacement of Bendix® air disc brake tappet and boot assemblies, tappet inner seals, and guide pins and boots.
- No. 80000 ADB22X Complete Kit (Bendix #K029164)
- All kits (80000, 80001, 80002) compatible with Bendix's new ADB22X-LT for trailer air disc brakes.
- No. 80001 Tappet & Boot Replacement Tool Kit (Bendix #K028829)
- No. 80002 Guide Pin / Pin Boot Service Tool Kit (Bendix #K029107)
- Made in the USA!



80000

Heavy Duty Truck Lock WHEEL LOCKS FLEET OWNERS AND OPERATORS: Wheel & tire theft is one thing you can't afford

For less than the cost of one tire, you can protect a complete Tractor and Trailer and avoid:



- Increased insurance costs
- Scheduling and delivery delays
- Additional expenses for downtime
- Thousands of dollars in stolen equipment
- Loss of perishable load
- Lost business
- Possible vehicle damage

Made in USA



Part No.	Description	Contains
52003	Wheel lock set for metric hub mounted disc wheels.	10 locks & 2 keys. Application-tandem axle tractor & tandem axle trailer.
52004	Thread: 22mm x 1.5.	6 locks & 2 keys. Application-tandem axle tractor or single axle tractor and single axle trailer.

Torq-Right® Truck Tire and Wheel Mounting System

To minimize wheel-offs and other problems associated with improperly mounted tire and wheel assemblies, the Tire Industry Association and the Maintenance Council of the American Trucking Association have established recommended best practices to mount and torque tire and wheel assemblies.



SC100 Stud Cleaner



The SC100 stud cleaner quickly and easily removes rust, road grime and foreign particles from wheel studs. Three carbon steel brushes engage the full thread and provide a clean surface for the wheel retaining nut allowing an accurate final torque.



SC100KIT Wheel Prep Kit



VIDEO

Call us to arrange a visit and individualized review of your wheel mounting procedures. We can also schedule a Torq-Right® class to update your techs on TIA and ATA recommended best practices.

Inspect all Components for Wear and Damage



ATG9755 5 in 1 22x1.5mm stud and nut inspection tool. Helps check for worn and oversized wheel holes, worn studs and bell mouthed flange nuts.



2215TPG - \$10.99 22x1.5mm Thread Pitch Gauge for Uni-Mount

Pre-Torque Wheel Nuts to 65 ft lbs

Rotate Wheel Mount Pad to 12 o'clock

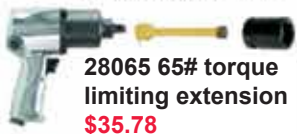

28065 65# torque limiting extension \$35.78

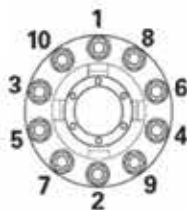

NEW OSHA 29 CFR 1910.177 wheel mounting procedure manual and charts. These are required by OSHA to be displayed in truck tire service areas or carried in road service trucks. **\$7.75 ea for OSHA24 booklet. OSHA 3400 3 Poster Set Available!**



Worn Stud

New Stud



Tighten Wheel Nuts to Final Torque



4AR1 Break Back Torque Wrench 600 Lb. Ft. Max or economy version 600FHTW - \$569.99



47501 475 ft lb Pre-Set Torque Wrench

Full RIST Procedures



Short Shank 1" dr Impact with torque limiting extensions (Extension kit KT130940)



WARNING: Wheels, studs, nuts and hubs that are not properly installed, inspected or maintained may not be safe. Failure to follow proper installation or maintenance practices may result in injury or death. Always use proper personal protection devices for safety and to avoid injury. **ALWAYS FOLLOW GUIDELINES IN OSHA 29 CFR 1910.77 FOR WHEEL MOUNTING.**

Bead Holder, Aluminum Wheel Protector, Beadkeeper

- Holds the bead in place against the wheel when mounting the tire on the wheel
- 31713 Bead Holder works on Super Singles and Super Wides

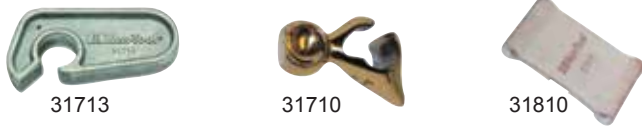

Ascot No.	Mfg. No.	Material	Stock	Weight	Price
472-31710	31710	Solid Brass	1.4 lb.	1.8 lb.	\$44.82
472-31713	31713	Aluminum Bead Holder - Works on Super Singles			\$21.85
472-31810	31810	Aluminum		12 lb.	\$25.68



Ascot No.	Mfg. No.	Description	Price
448-12894	12894C	Beadkeeper Yellow Rubber Coated Steel	\$39.99
448-32894	4483289	Beadkeeper Wide Mouth Blue Rubber Coated (for ALCOA)	\$31.99
448-22894	12894	Bead Saver System Beadkeeper	\$28.99

Universal Demount Tool Kit 20415

- Safe, simple, fast, economical, and the most universal tire demounting system on the market
- Works as a hand-held tire machine and shines where other tools fall short
- Tackles the hard 19.5 reverse hubs and grader tires and can be used on all tire sizes from 10" ATV tires and up
- Great for agricultural tires, one-piece grader, loader, forestry and backhoe tires



20408 - Tool Demount Pneutek Impact Driven (Tool Only)

Ascot No.	Mfg. No.	Description	Price
402-20415	20415	Tool Demount Pneutek Impact Driven	\$899.99

T115 Truck Tire Changing Stand **\$295.96**

Stand handles wheels or open rims 16.5" to 24". Double-slide adjustment with locking device prevents twisting so it stays aligned with the wheel or rim. Stand is the ideal height for driving off beads or demounting tires.



Golden Tool Tubeless Truck Tire Mount/Demount Tool

- Demounts/mounts 17.5" to 24.5" tires
- Use on all tubeless truck tires including super single/duplex tires, radial and bias
- Eliminates the need to lift tire and rim to remove the bottom bead, preventing possible strain or even serious injury



Ascot No.	McGee No.	Description	Price
448-00100	TNT100	Complete Tool	\$574.99
448-12320	44812320	Economy Complete Tool (AME)	\$399.99

TNT200 for super singles

T950 IronMan™ Ergonomic Wheel Lifting Bar **\$89.99**

Reduces back strain. Easily and safely lift heavy, awkward truck tire and wheel assemblies. Extremely useful in outdoor conditions – when truck tire and wheel assemblies can become wet and slippery. Standard sizes including 22.5" and 24.5" wheels, plus European (which have 1" lug holes), Super Wide and even the Super Single



Stow & Go™ 4-Way HD Lug Wrench - 35636

- The Stow & Go™ 4-Way HD Lug Wrench folds to save space in your trunk and locks into place for easy use.
- Push button in center allows wrench to fold after use.
- Sliding arms give extra leverage for removing lug nuts.
- Made of heavy duty and durable alloy steel.
- 17mm, 19mm, 21mm sockets, and 1/2" square drive adaptor to be used with other sockets.
- 16" in length.



\$25.48

Wrench Lug LT Truck 4-Way **T90 - \$49.33**

- Sockets: 7/8" deep well, 15/16", 1", & 1-1/16"
- Various 4-way wrenches available.



Lt Spare Tire Removal Tool Set

- Lower spare tire in 10 seconds
- Eliminates hunt for customer's tool
- Hanger included
- Do not use impact wrench
- 7 piece kit
- Replacement tools available



Hot Deal!
\$89.99
#96090A

Tubeless Tire Irons

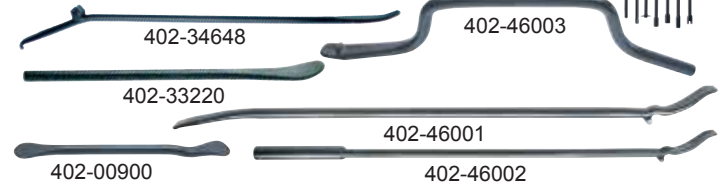

- Use C bar with the B extension bar for easier use on large, wide-base truck tires
- Use on standard and large truck tires, including industrial, farm, buses and tractors

Ascot No.	McGee No.	Description	Length	Price
402-00900	T9A	Small Tire Mount/Demount	9"	\$21.99
402-33220	T20A	Curved Tire Mount/Demount Spoon	30"	\$31.44
402-33219	T19A	Straight Spoon	30"	\$31.44
	T45A	Tubeless Mount/Demount	37"	\$65.31
402-34645	T45AC	Classic T45 Truck Tire Tubless Iron	37"	\$76.95
402-45004	T45HD	HD Truck Tire Tubless Iron	41"	\$94.72
402-46001	T46A	Med. Duty Mount/Demount Iron	36"	\$64.20
402-46002	T46B	Mount/Demount Iron	36"	\$76.08
402-46003	T46C	Offset Bar For Deep Well Tires	22"	\$52.67
402-33223	T23A	Lock Ring Tool	30"	\$30.65
402-34648	T48A	Lock Ring Tool	37"	\$65.03

Duck-Billed Bead Breaking Wedges – Fiberglass Handled



Ascot No.	McGee No.	Handle No.	Length	Weight	Price
424-35429	TG11E	TG11EH	32"	9.1 Lbs.	\$189.99

KenTool Porkchop™ Wrenches

- Holds outer cap nut on dual wheels while turning inner nut
- Lip fits in hole to secure wrench in place
- Fits standard and metric cap nuts



Ascot #	McGee #	Description	Size	Weight	Price
406-30609	TX9	SAE	1-1/2"	.4 Lbs.	\$22.99
406-30610	TX10	Metric	35 mm	.4 Lbs.	\$22.99
406-30612	TX12	Metric	41 mm	.4 Lbs.	\$22.99

28 CUSTOM INFLATION SYSTEMS & SERVICE TRUCK PACKAGES



Auto Inflators save time and money. Proper inflation creates longer tire wear and increased fuel mileage. These self-calibrating units are accurate to +/- .03 psi. Can be used as a reference point to calibrate hand held gauges. Allows remote control of the inflation process, allowing the technician to avoid the "blast zone" during inflation.

Let us design a custom installation for your shop



Single Unit Controller



89XDB2



47711624 4-way accessory block and 47747732 6-way manifold available

*Two tire inflation system includes two 10 ft. flex polyurethane inflation hoses with fittings. 89XDB4 includes two 10 ft. and two 8 ft. flex polyurethane inflation hoses with fittings.

- In-Line air filter provides clean air for long term



- durability and trouble free operation
- USA manufactured air chucks assure leak-free tire valve connection.
- Flexible, light weight polyurethane inflation hoses with swivel connections provide quick, secure inflation.

Complete Truck Service Package featuring Quincy Powered Compressor



Complete Truck Service Package

As low as \$4,399.99!

*Pricing variable due to compressor

McGee #STP10

Includes these items:

- 13HP Champion or Quincy Compressor with Honda engine - HGR73H or G413H30HCB
 - Electric Start
 - Automatic Idle
 - Fuel Pump
 - Air Gauge
 - Easy Access Tank Drain
- 10 Piece Truck Socket Set - 3190
 - 13/16" Square, 7/8" hex, 13/16" hex, 1" hex, 1-1/16" hex, 1-1/2" hex, 1-1/16" deep, 1-1/8" deep, 1-1/4" deep
 - Plus metal box
- 15517786 1" Square Drive Impact
- Dual Foot Air Chuck
- Truck Air Pressure Gauge
- 50 ft. 1/4" Air Hose
- 50 ft. 1/2" Air Hose
- Air Couplers
- 20-ton Hydraulic Jack



Steel surcharge may apply
Items may vary slightly from photos above.

Let McGee Company design the right kit for you or customize your own package from large to small OTR!



Truck Package Components



11076 - Original Maxi Bead Breaker

- Lightweight aluminum reduces weight by 40%
- Adjustable clamp allows for a perfect fit - regardless of the size of wheel
- Unit delivers 10 tons of force
- 2.75" (7 cm) stroke breaks beads often with only one "bite"
- Weight 31 lbs (14.1 kg) (Competitive to IMT1000)



Bead breaker pump chart

11076
\$1,999.99

"Combi" Tire Bead Breaker

- Works on a single, two and three-piece truck, agricultural and earthmover tire/rim
- Breaks beads in seconds using 10,000 lbs. of force
- No screws, bolts or attachments
- "Combi" bead breaker will not work on five-piece earth mover giant wheel/rim



422-11010



422-16200

The 16200 upgrade kit can be added to Combi Bead Breakers in order to convert the tool so that it can work on new 3 piece wheels.

Air Reducer with 6" Whip Hose

- Maintains tool's recommended working air pressure
- Tamper-proof preset value, 110 PSI
- Assist in lengthening the life of hydraulic pumps & lifting equipment
- Ideal for all hydraulic tools to extend their life



10601k
\$49.99

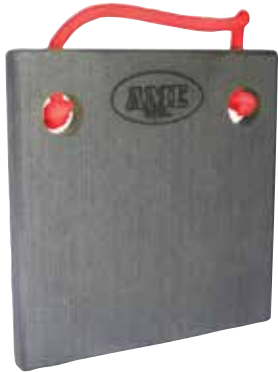

14464 12x12x1" Jack Plate
D1818 18x18x1" Jack Plate available
14464 - **\$104.99**



13000AME



AJ506B

55- and 100-Ton Aluminum Rams

Get the strength of a steel ram but with about half the weight. These single-acting, spring-return rams are easily carried around the shop, or into the field for on-the-vehicle repairs. They are ideal for truck axle correction, trailer frame straightening, general vehicle maintenance, and heavy-duty lifting.

McGee No.	Capacity	Low Ht.	Raised Ht.	Wt	Price
AJ506B (13141)	55-ton	12.25"	18.25"	29 lbs	\$1099.99 (base included)
13000AME	100-ton	11"	17.5"	53 lbs	\$1850.99 (base not included)

Hydraulic Rams

Used to push off rear rim flange and tire bead on earthmover wheels

- For all earthmover tires, trucks and perfect for construction

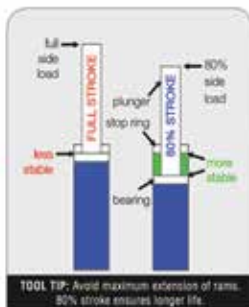
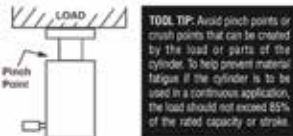

Mfg. No.	Cap. (Tons)	Collapsed Height	Stroke	Price
10301	10	4-3/4"	2-1/8"	\$249.99
10302	10	6-3/4"	4"	\$259.99
10303	10	9-3/4"	6-1/8"	\$279.99

Ascot No.	McGee No.	Description	Price
422-11010	10101	Bead Breaker	\$658.99
422-11020	11020	Modified "Combi" Tire Bead Breaker	\$999.99
422-16200	16200	Conversion Kit for Combi Bead Breaker	\$479.99

Modified "Combi" Tire Bead Breaker Kit

- Modified 11010, the most popular tool for breaking beads on all agriculture wheels
- Most affordable bead breaker for new 3 piece wheel assemblies
- Modified jaw and feet allow for larger grab on larger wheel assembly



15920

422-12020 (full kit)

Ascot No.	McGee No.	Description	Price
422-12020	12020	Bead Breaker Kit. INCLUDES: 11010 Bead Breaker, 15920 Pump and 16040 Hose Assembly	\$1499.99

Hy-Flo Hydraulic Coupler

- Lightweight yet durable - 3/8" couplers
- Includes ram and hose portions
- Interchanges with OTC, Power Team, AME & ESCO hydraulic products

10600 Set

10606 10605

AHP20H



Ascot No.	McGee No.	Description	Price
318-09795	10600	Hy-Flo Hydraulic Coupler Set (9795)	\$49.99
318-09796	10606	Ram Female Half (9796)	\$26.24
318-0978	10605	Hose Male Half (9798)	\$15.22
318-04960	AHP20H	Nylon Core Synthetic Fiber Reinforced 8ft x 3/8" & half coupler 10605	\$64.99

1005LOM - \$159.99

McGee Company has the right tools when you need them. Now stocking 1005LOM Service Truck Lockout kit to keep people safe and avoid operating vehicles when they shouldn't be.

- Durable latch case that is super small!
- Reorder parts whenever to add to or replenish.
- Safety red items in case to draw attention.
- Contains Steering wheel cover, do not operate tags, padlock, steel hasp, and glad hand lock.



Other vehicle lockout kits available

Service Truck Packages and Cribbing by Service Truck Packages



OTR Inflation/Deflation Kit



Tool Identification Chart by Rim



McGEE COMPANY RECOMMENDED RECIPROCATING COMPRESSOR MAINTENANCE

This guide is not designed to be a complete maintenance manual for all air compressors. Refer to manufacturer's manual for detailed instructions. If the unit is in an excessively dusty area, increase frequency of all checks! Always turn power off before servicing.

DAILY CARE . . .

Check for proper oil level
Drain any condensate from receiver and traps
Check for any unusual noise or vibration

WEEKLY CARE . . .

Clean air filter
Clean all external parts of compressor and driver
Safety valve should be tested manually to see that it does not stick

MONTHLY CARE . . .

Inspect entire air system for leaks
Inspect oil for contamination and change if necessary
Check belt tension and wear

EVERY SIX MONTHS . . .

Change Oil
Inspect valve assemblies

Call 800-525-8888 today for details!

Detail maintenance chart available. Preventive maintenance programs available in Colorado.

Quincy QT® Compressors "Rated #1"



Meticulously designed for maximum productivity. Completely rebuildable with stainless steel valves and heavy duty cast iron crank case and cylinders. Leading the industry with the most CFM per brake horse-power. Includes ASME receiver, enclosed belt guard, EPA high efficiency motor, and loadless auto stop/start.

Part No.	HP	Electric Spec.	ACFM at 175 PSI	Tank Size	Tank Style	Price
451CS80VCB1MAG	5	230V, 1ph	17.2	80	vert.	\$2,949
471CS80VCB1MAG	7.5	230V, 1ph	22.6	80	vert.	\$3,275
P4103DS12VCB3MAG	10	230V, 3ph	35	120	horz.	\$5,495

3-Year Warranty Program



- Quincy's True Blue 3-Year Warranty
- Register unit within 10 days after purchase to activate warranty
- Purchase and use genuine Quincy filters and lubricant during the warranty period. (Proof of purchase required)
- Receive a 3-year limited warranty on the compressor.
- Receive a 2-year limited warranty on the package.
- Motors and engines are warranted by the original manufacturer.



Vibration pads available CP3x3

Ask about our Energy Audits for rebates from energy companies

- Electric Operated Drain Valve 1/2"
- 1/4" NPT Inlet & 1/2" Female Pipe
- 300 Maximum Working Pressure
- 110 Volt w/6Ft Power Cord
- Y-Strainer & Ball Valve Included
- Adjustable Timer For Blow Down
 - » 1/2 Second - 45 Minutes Interval Time
 - » 1/2 Second - 10 Seconds Discharge Time

2523J - \$123.00



ELIMINATE WATER! Where Water Comes From

The atmospheric air entering a compressor intake contains water vapor. Because of the effects of compression, most of this water vapor turns into troublesome liquid water in your air lines.

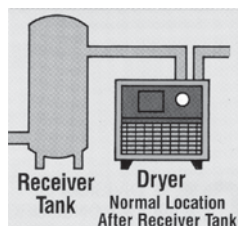

QPNC13	13 CFM 1PH 115V Refrigerated Dryer	\$1,241.00
QPNC21	21 CFM 1PH 115V Refrigerated Dryer	\$1,332.00
QPNC42	42 CFM 1PH 115V Refrigerated Dryer	\$1,615.00

Quincy Gas Powered Compressor

Now \$3,399.00! Champion version available

Heavy Duty 13HP Honda engine, 2 stage compressor, 23.6 CFM at 175 PSI!

Model G413H30HCB Quincy Gasoline Air Compressors



- Truck Bed Mountable, ideal for Field Service Applications
- Heavy Duty Two-Stage Compressors
- V-Belt Drive with Totally Enclosed Belt Guard
- Unloader for loadless start prolongs motor life
- **Each new assembled unit comes with a 3-year limited warranty**

WARRANTY INFORMATION

NO BULL



Optional NO BULL Warranty

- Pro/Pro+/Max Package with Extended Warranty Kit
- 3-Year Pump/2-Year Package Warranty
- OEM Parts/Fluids and Online Registration Required



EWK101-31/Quin-Gp D



*Must purchase associated kit at the same time as the compressor to receive warranty extension

Proper Piping for Compressed Air

- 100% aluminum for compressed air, copper ok as well.
- Aluminum offers excellent mechanical resistance to pressure and to impacts.
- The upgraded design of the new PPS1 aluminum fitting is more compact, lighter and more resistant.
- The aluminum alloy used, combined with epoxy paint on the outside and a treatment on the inside, protects the pipe against the risks of oxidation and corrosion.
- Simply insert the pipe into the fitting and then tighten the PPS1 fitting.





MCGEE COMPANY
 offers turn key solutions for your shop or dealership equipment needs, lubrication systems, and compressed air including free CAD design!
Call today for pricing
1-800-525-8888



Two-Post Lifts

- Original "Double S" single piece column design maximizing strength
- Slider block bearings of Tivar 1000 polyethylene that self-lubricate and are maintenance free
- Adjustable height options with column extensions
- Asymmetrical and symmetrical designs to suit your needs
- Trio three stage arms for asymmetrical lifts
- Shockwave and standard (10,000-20,000lbs) configuration available in two-post
- Multi-position column locks



Our experts can help you design your air piping systems, lift installations, and lubrication systems to fit your needs.

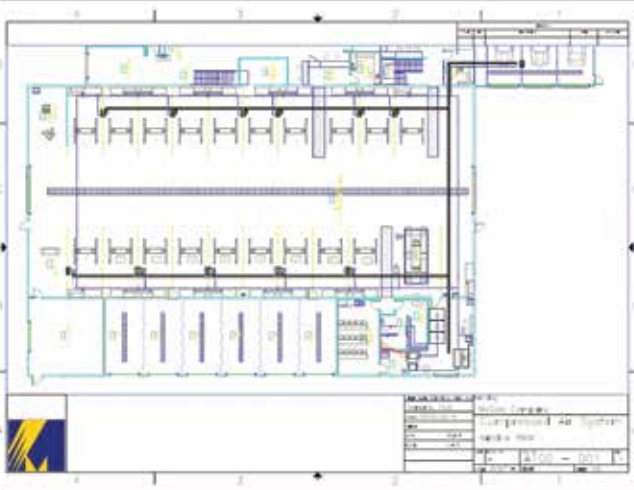

The World's Most Trusted Lift™ A DOVER COMPANY

Rotary Symmetric / Asymmetric

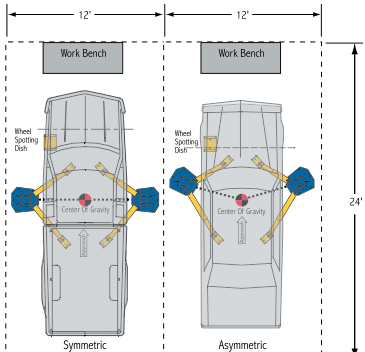

- Benefits of True Asymmetric Lifting:**
- When the lift is loaded properly, doors can be opened and the vehicle is positioned a minimum of 24" away from the nearest obstruction.
 - With true asymmetrical lifting, the columns are rotated 30° to place the approximate center of gravity of the vehicle in line with the optimum load capability of the column, reducing unnecessary wear and tear on the column, carriage and bearings.
 - Asymmetrical lifting provides more clearance at the rear of the columns (the open door contact point) approximately 117" vs. 103".

Versymmetric®* / 2-in-1 Lift

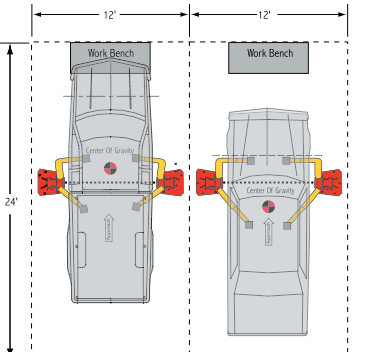

- Pitfalls of Versymmetric / 2-in-1 Lifting:**
- When the lift is loaded, long vehicles that should be loaded symmetrically extend too far forward, leaving no room for work benches or walking area. Asymmetrical lifting positions the vehicle too far back, which intrudes into the drive-through area or even an exterior bay door.
 - Versymmetric lifting places the approximate center of gravity of the vehicle in front of or behind the optimum load capacity of the lift. By doing so, wear and tear on the column, carriage and bearings is increased.
 - No spotting dish makes vehicle positioning "Guesswork".
 - The front arm is offset 5" which requires short wheelbase vehicles be pulled further forward to clear the front tire, which reduces the clearance to open doors.

SHOCKWAVE Equipped Lifts

- 2X Faster rise and descent than standard lifts
- DC powered which reduces installation/operating costs
- Two standard Group 24 batteries charged by the 110v that runs the lift removes the need for expensive 220v wiring and can operate during power loss
- Spotline motion activated laser helps spot vehicles the first time
- Available on lifts from 7,000-20,000 lbs



Inground Smartlifts

- 10,000-12,000 lbs capacity models available
- High efficiency power and air per lifting cycle, selected in key lead projects
- Reduces space usage and allows more lifts
- Trio three stage arms for pinpoint location
- Shockwave or standard available
- New wide inground (SL210W or SL212W) futureproofs your business, as they can service electrical vehicles.



Versymmetric and 2-in-1 style lifts have short arms on the front and long arms on the rear. This is done to accommodate the pick up points of vehicles that are shifted to the rear in order to improve open door clearance for the technician getting in and out of the car. In a symmetric load condition the vehicle is centered fore and aft (not shifted to the rear). The short front arms are unable to reach the pick up points in the symmetric load condition. This can be easily demonstrated by picking up an F350 as shown.

Smartlift Green Features

- Uses only 19 quarts "Bio-Fluid"
- An entirely closed system housed in a recycled polymer composite containment which protects the environment and the lift
- The Smartlift uses only .045 kWh of electricity and .01 cfm of air per lifting cycle
- Steel components and housing can be recycled again at the end of the lift's lifecycle



LIF 889_v1_v01_2006.02
 ©2006 Rotary®. Printed in U.S.A. All Rights Reserved. Unless otherwise indicated, ROTARY, DOVER and all other trademarks are property of Dover Corporation and its affiliates.

* VERSYMMETRIC is a Registered Trademark of Challenger Lifts, Inc.



Each LOCKLIGHT™ includes:

- Indicator light assembly
- Pressure switch
- Mounting Bracket
- 10' of electrical wire

- Compatible with most surface and inground lifts using electric/hydraulic power units
- Retrofits to most existing lifts
- 110v and 220v configurations

Part #FA834/110v
Part #FA835/220v



Door Defender™

Rotary's new door defender allows technicians to easily enter and exit the vehicle without damaging their customer's vehicles. The door defender is a low profile solid rubber guard designed to fit over the two-post lift carriage. The N823 door defender kit includes: 1 door defender, adhesive to attach to the lift, a Rotary decal and instructions.

Model #N823

Norco under hoist stand 3/4 ton

- Lightweight, slender design makes handling easy, even in close quarters
- Quick adjust spin handle with thrust bearing eliminates wear and provides ease of turning under load
- Extended height 81"



81033A - \$169.99

FJ6259KIT (Set of 4)



FJ6258KIT (Set of 2)

FJ6257KIT (Set of 2 for Trio)

2019 Chevy & GMC pickups require a specially designed adapter to properly and safely engage the truck's newly designed wider frame.

McGee is stocking for Rotary and Challenger.



RA, TA, and Trio adapters for Rotary and other brands available, call for pricing!



Lifting jack pads for Tesla models

TJP4 - \$24.99

- Set of four in convenient carrying case
- Protect the vehicle, battery and paint from damage
- Can be used with floor jack or 2-post lifts
- Top piece fits into designated factory lifting points



Rubber lift pad for any lift available!



Ascot No.	Mfg. No.	Description	Application
309-00003	JOK03M	Rubber Lift Pad - 5" Round	Nussbaumlifts
309-00005	JOK05M	Rubber Lift Pad - 4" x 5"	BenPearsonlifts
309-00007	JOK07M	Rubber Lift Pad - 5" x 5"	Forward,Worth,American, Gemini, Grand, Tuxedo, Eagle, & Whip lifts
309-00009	JOK090	Rubber Lift Pad - 4" x 4"	Challenger CL9 and CL10 lifts
309-00022	JOK22D	Rubber Lift Pad - 3.25" x 4"	Rotary SPO10, SPO12 lifts
309-00014	JOK140	Rubber Lift Pad - 5.25" Round	Challenger CL10, Quality lifts
309-00011	JORB-1	Rubber Block 1.5"	Rotary Airjacks and all Mid-Rise pad lifts
309-00013	JORB-3	Rubber Block 3"	Rotary Airjacks and all Mid-Rise pad lifts

Norco 1/2 ton transmission Jack

- Fully adjustable universal saddle with adjustable corner brackets and safety chain, 72" raised height
- Safety overload system prevents jack from being used beyond rated capacity
- Foot operated pump and lowering pedals
- Two-stage flash chromed rams inhibit rust from entering hydraulic system
- Wide base with polyurethane wheels to protect floors.



72500E - \$1,199.99

Wheel Arm for lifts

92100 - \$109.99

- 100 lbs Capacity
- Set of two arms
- Comes with 2 magnetic tool trays, hex key, and mounting shims

Ask us about fuel tank saddles



Wheel arms hold tires at the lift arm height – great for tire rotations and brake jobs

Air/Electric Utility Boxes

- Two 110v electric outlets and air connections mount easily to any column and provide quick access to utilities.
- The filter/regulator/lubricator extends the life of your airtools.



FA5911BK (with filter/regulator/lubricator)
FA5910BK (without filter/regulator/lubricator)

Ask us about ALLPART non-Rotary replacement power units for 2 and 4 post lifts

- 1phase
- Up to 12k lbs.



Why Coats?

All equipment installed and training by a factory tech · In stock at multiple McGee locations · Extended warranties · Building equipment since 1947 in TN · General repair to HD, AG, and Industrial options

Ask about end user rebates!

1300

- Direct drive motor with 40mm shaft
- 2D Auto data entry
- 220V 1/3ph
- 8-30" diameter wheel range with max tire diameter of 44"
- Warranty: 3 Year Parts, 6 Months Labor



1500

- Direct Drive Motor
- Laser Guided Tape-A-Weight
- Side Shadow Board with Basic Pro Kit
- Auto Start Hood
- Static-On-Screen
- New Display Mounting Bracket
- Automatic Data Entry (Distance/Diameter/Width)
- 12 o'clock Inboard Laser
- Stop, Lock & Index

Extended 3 year warranty



525 WHEEL LIFT FOR DIRECT DRIVE BALANCERS

- 160 lb capacity, Air Operated
- Mounts to Direct Drive wheel balancers: 1300 1400 1500 1600
- Hi-Visibility floor ramp for easy roll on/off
- Smooth scissor-lift action
- Sliding work platform for easy operation
- Small footprint, low center of gravity for superior stability
- Simple foot-pedal operation



COATS ALIGNMENT SYSTEMS AVAILABLE; CALL FOR DEMO!

Call today for best prices!
1-800-525-8888

MAXX50 - Good!

- Wheel Handled - Alloy, Steel for Car & Light Truck
- Rim Diameter - 6-24"
- Max Tire Diameter - 50"
- Max Rim Width - 16"
- Bead Loosening Width - Up to 22" Wide
- Wheel Clamping System - 4 Clamps, Air Cylinder Operated
- Bead Seating Air Volume - 5.4 Gallons in Tower
- Air Drive System - Up to 4 HP*
- Electric Drive System - 110V Electric Motor
- Footprint - 74"w x 81"h x 44" d
- Ship Weight - 750 lbs, Low Center of Gravity for Stability
- Warranty - 3 Years Parts, 6 Months Labor
- Part Numbers -
Electric 110V: 800MAXX50
Air: 800MAXX50A

*Max air motor HP dependent on shop air pressure



MAXX80 - Best!

- Wheel Handled - Alloy, Steel for Car & Light/Medium Truck
- Rim Diameter - 6-24"
- Max Tire Diameter - 50"
- Max Rim Width - 16"
- Bead Loosening Width - Up to 22" Wide
- Wheel Clamping System - 4 Clamps, Air Cylinder Operated
- Bead Seating Air Volume - 5.4 Gallons in Tower
- Air Drive System - Up to 4 HP*
- Electric Drive System - 220V 2 HP Electric, 110 Electric Motor
- 220V Electric Requirements - 220V, 10amps, 1PH, NEMA L6-20
- Footprint - 74"w x 86"h x 44" d
- Ship Weight - 850 lbs, Low Center of Gravity for Stability
- Warranty - 3 Years Parts, 6 Months Labor
- Part Numbers -
Electric 220V: 800MAXX80220
Electric 110V: 800MAXX80
Air: 800MAXX80A

*Max air motor HP dependent on shop air pressure

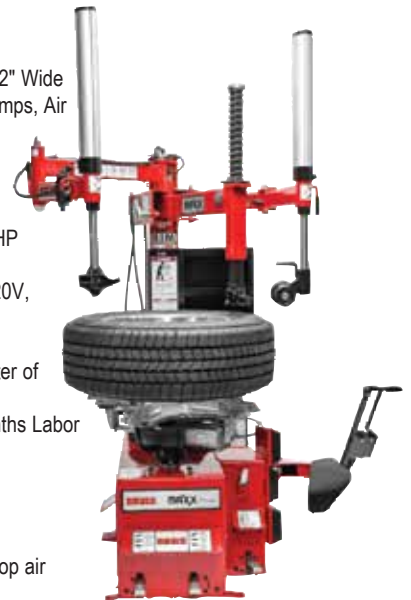

CALL FOR QUOTE ON BRAKE LATHES

Tire Changer Duckhead Specials!

Hybrid Duckhead Mount/Demount Tool

85608959 **\$198.36**

Replacement tail
85608961



For 50X, 60X, 70X

Coats Leverless DuckHead®

Coats Leverless DuckHead® hook and tail booties provide the proper rim protection for all leverless DuckHead® systems - Proguard

89233409 6 hooks, 2 tails **\$119.99**

Pictured: PN 89233409



For Coats 50X and 70X

Part # 182788



\$117.95

Grey Plastic High Spoke Mount/Demount Duckhead® Tool

For Coats 50X and 70X machines

Part #184432



\$34.99

183606 - Sock Bead Loosener Shoe 2/PKG



\$38.75

Plastic Duckhead Kit

Part #183061
444-01220



Special \$31.99

Head, Mount/Demount, Polymer Red

Hunter TC3250/3500 (1 ea.) Part #2216752



\$23.99 ea.



Hunter TC500 Series

Part #RP118314813



\$32.99 ea.

Hunter TCX Series "Wing" Duckhead

RP11811400327



\$47.97

85607787 Grip Max Plus Laminated Clamps (4) 6"-24"



\$899.99

Plastic Handled Brass Sidewall Brush

- Densely packed brass bristles
- Great for cleaning white sidewall tires



99593

Wooden Handled Wire Brush with Metal Scraper



Ascot No.	McGee No.	Description	Price
395-13124	99593	8" Plastic Handled Brass Sidewall Brush	\$8.99
535-00150	25150	14" Wooden Handled Wire Brush	\$3.35

5500 Low Profile Bead Lever Tool **Now \$49.95**

Designed by technicians to assist with hard to change low profile tires. The easy grip ergonomically designed handle allows the user needed leverage for the toughest of sidewalls while remaining a safe distance from the face of the wheel.



For All Rim Clamp Tire Changers

Part # 181354 **\$36.49**
444-81354



Slide Cover for Bead Lifting Tool

Protects custom rims.

85000783 - Slide Cover for Top of Bead Coats Lifting Tool - 10 pk - Coats **\$49.99**

RP11811400098 - 4 pk for Hunter tire machines

Lever sleeve protector, Hunter **\$40.64**



85000783



Coats Replacement Tire Changer Air Hose - 5 ft.

Coats Replacement Tire Changer Air Hose with Euro Chuck

Part # W44RJ5

\$13.92



RP11811400325 Leverless Mount Head Insert Kit TCX V3 **\$56.99**

RP11811100303S

Protector Plastic for Old TCX Steel Mount Head **\$1.78**

Plastic Inserts for 182788 Metal Mount/Demount Head (Pkg of 2) 50X, 60X, 70X Model 182961

\$7.99



Plastic Inserts for 182788 Metal Mount/Demount Head (Pkg. of 12) Model 182963 444-82963 **\$26.99**

183604 Quilted Clamp

Socks (10 pk) for series machine - 50X, 60X, 70X



\$49.99

8560716108 Replacement black grip for new style Grip Max Plus



\$68.34
(8 each)

High Grip Jaw Protectors

Polymer jaw covers prevent metal-to-metal contact when performing external clamping. - TCX500 Series Machine

RP11811100358 - 8 ea. **\$109.99**



COATS

85610104 ADJUSTABLE PIN PLATES SET OF 3 FOR LUGS 3,4,& 5 \$2,699.99

- Works on any 40 mm balancer
- Adjustable design provides fast and easy clamping
- Lug clamping and centering prevents damage to alloy wheels
- 85609688-5 lug, 85609689-4 lug, 85609690-3 lug



85607503 - SLIDE NUT PREMIUM 2 JAW 40MM \$349.99

- Solid metal body lasts longer and won't shatter, if dropped.
- Binary Thread Engagement stays fully open during installation, eliminating wear from dragging the teeth across the balancer's threaded shaft.
- Fits coats 40mm shafts
- 85608312- No mar ring & 8112106 Pressure cup



8111935 - SPACER LT TRK BACK CONE \$329.99

- For use on certain deep offset applications.
- Can be used on any 40mm wheel balancer.



Steel ProGrip Quick Nut with Handles and Pressure Cup



483-40806

HW124408006 - \$299.99

Cemb 41FF83148 - \$289.99

Quick release wingnut with reverse mounting cup & no-mar ring, not for use with HD Truck balancers

Creates pressure necessary for Road Force balancers.

HUNTER, COATS

All Hunter Models exc 700 and DSP9500 90-92; All Coats Models Quick Nut Only

Coats Models 700, 775, 800, 825, 850, 875, 925, 950, 1000, 1025, 1030, 1035, 1175, 1250, 1255 (40mm shaft upgrade), 6275HS

\$779.99



483-40110 ProCollet Kit 40mm

9 pc.
2.07" to 4.76"

The Low-Taper Collets are superior to standard cones because they have more contact area and engage the wheel at a better angle; they are also necessary for Clad Wheels because they are shorter and only contact the metal part of the wheel. They can be used for "standard" wheels as a replacement for the cones.

In Stock — Call for best price!

HUNTER

2027651 - BULLSEYE COLLET KIT GEN \$999

Kit includes:

- A. 175-392-1 6 in. clamping cup
- B. 46-653-2 Performance wheel & light truck spacer
- C. 14-1470-005 Cone carrier bracket support
- D. 56-70-2 Front balancer cone carrier
- E. 20-2683-1 Passenger to 3/4 ton dual-taper collet kit
- F. 106-157-2 Protector sleeve



2033581 - COLLET KIT ECONOMY MD \$1,199

- Does not handle the large 8 lug/8.7" bore found on some medium duty trucks. 20-3155-1 covers that application and includes 20-3116-1. Includes application chart.



2036981 - FLANGE PLATE AND STUD KIT ADJUSTABLE \$1,399

- This durable aluminum design can adjust from 98 to 210mm bolt patterns and covers almost all wheels in this range. It comes with (3) three sets of (5) five pins each to handle any application. These pins are 2, 2.5 and 3.25" long with diameters of 1 to .75" respectively.



Light Truck Cone Kit

\$399.99

HW150280091 28mm

Allows balancing truck wheels with center holes from 4^{13/16}" to 6^{7/8}". Used on rims with an alignment pin on the back. Double-sided cone fits all Coats balancers

40mm - 48340091 (113277) **\$249.99**



\$39.99



Model #61123 Balancer Calipers
482-89011

Works on any passenger balancer. Equal to Coats 61123 or 309011 or Cemb 46FC77653

\$279.99



Part #85009998 08 40mm I.D. - Shaft, Hubnuts, & Press Drum
Nut-Slide, 2 Jaw, 40mm w/drum, for use on 700-1250 Coats models or Cemb with 40mm shaft
28mm version 85009996

\$139.23



Model #112103

40mm I.D. - Shaft, Hubnuts, & Press Drum

Hub Nut, Handle, Solid, 45mm for standard thread pitch (not for XR-Series) 28mm - 110543

\$279.20



8500920401 Balancer Shaft 40mm Balancer Shaft for 850, 950, 1050, 1055, 1250, XR, & 1150 Models

AutoSock has the OE Approvals!



AutoSock is mentioned by name in the above OE manuals.

AutoSock is approved by leading international car manufacturers.

Why sell or use **AutoSock**.

- ⊕ OE trusted & approved by name
- ⊕ The original ATD pioneered by textile scientists
- ⊕ Fewer SKUs than the competition with better coverage with 300 more tire sizes!
*Comparison as of 6/15/23
- ⊕ Faster/easier to put on than chains
- ⊕ Multilayered design for durability & wear indications
- ⊕ Approval all the way through six axel vehicles throughout the US

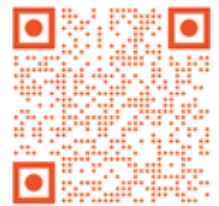

www.AutoSock.us



Not all Traction Devices are Created Equal!

	AutoSock	Competition
Made In	India	China
Passenger Number of SKUs	10	16
Meets EU Winter Traction Standard	Yes	No
3rd Party Testing	Yes	No
Wear Indicators	Black innerlayer showing	Tearing
Max Speed	30 mph	25 mph
OE Approvals**	Yes***	No
Side Webbing	Yes	No
Designed to Fal Away From Vehicle	Yes	No
Durability	Two Layers	One Layer
Truck Approval up to 6 Axel & Below	Yes	No



*Comparison data 6/15/2023

**19 OEs as of 6/15/23 with AutoSock mentioned by name. Most up to date info at www.AutoSock.us

***Only DOT approved ATD product up to six axel vehicles in WA



- ⊕ **Less weight than chains**
- ⊕ **No damage to vehicle**
- ⊕ **No climbing under vehicles to grab broken chains**
- ⊕ **Great for low wheel clearance vehicles**
- ⊕ **Faster to put on, less than 5 minutes!**

Showroom displays for the floor or counter available!

DISTRIBUTORS WANTED



A specially designed surface pattern that makes the total contact area exposed to dry friction as large as possible.

AutoSock® gets fuzzy "hairs" between and at the contact areas in order to increase the friction on snow and ice.

Mesh keeps snow out of the tread and wheel well while the orange straps help with centering and easy removal.



Colorado DOT demonstration

AutoSock for Passenger Cars - Max. Traction Force on Snow

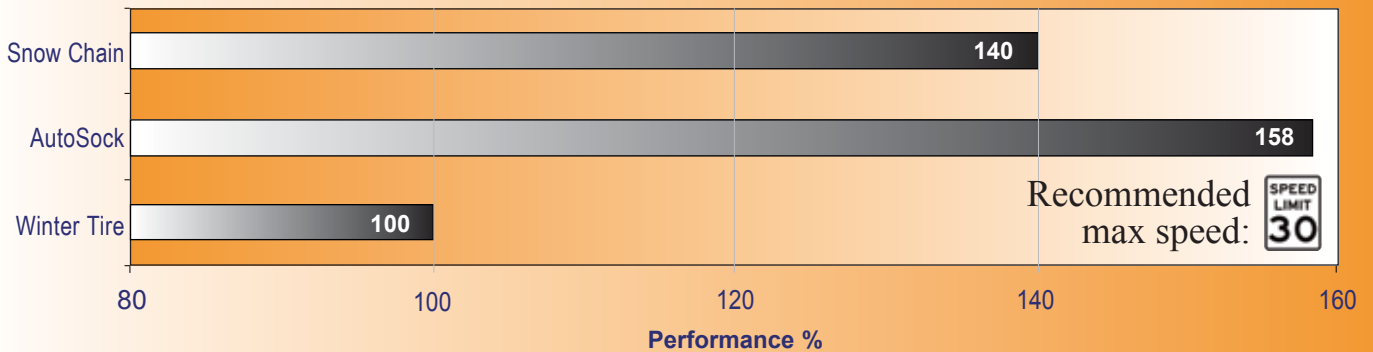

DATE: Dec 06 2007	AIR TEMP.: -7°C/25°F	TIRE SIZE: 205/55 R16	INFLATION FA: 3.0 bar	TEST VEHICLE: Pontiac FWD
LOCATION: Loveland Pass	CONDIT.: Dry snow, cloudy	ABS: on	INFLATION RA: 3.0 bar	TEST SURFACE: Packed Snow

AutoSock for Truck - Max. Traction Force on Snow

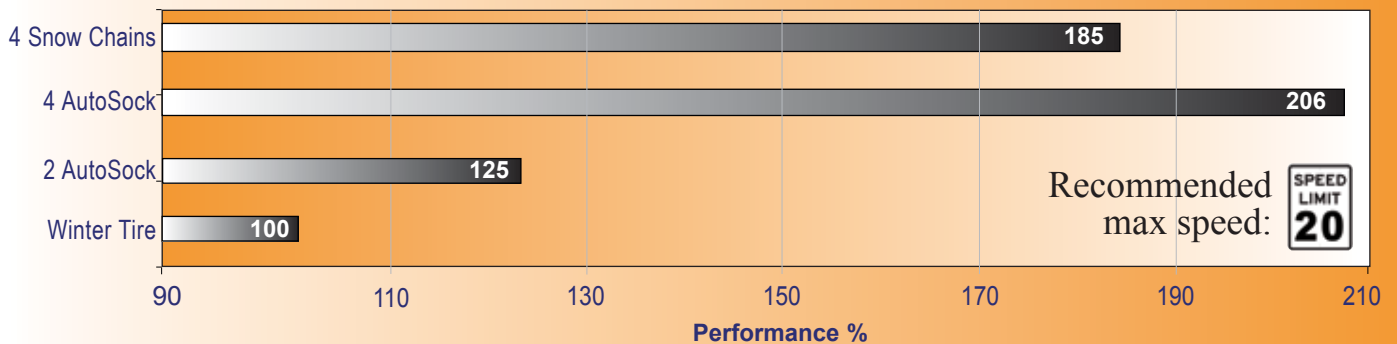

DATE: Dec 06 2007	AIR TEMP.: -7°C/25°F	TIRE SIZE: 295/70 R22.5	INFLATION FA: 8.0 bar	TEST VEHICLE: Peterbilt
LOCATION: Loveland Pass	CONDIT.: Dry snow, cloudy	ABS: on	INFLATION RA: 8.0 bar	TEST SURFACE: Packed Snow

TIRE CHAINS



Laclede™ Wide Base Truck Chains

Tire Sizes			Non-Cam Stock No.	Cam Stock No.
8.25-15LT	275/70R16LT	235/75R17.5	3210R	3210CAM
10-15LT	285/65R16	245/70R17.5		
265/70R15LT	295/50R16LT	245/75R17.5		
265/75R15LT	235/80R17	255/65R18		
305/50R15	245/75R17LT	P255/70R18		
31X10.50-15LT	255/60R17	P265/65R18		
33X10.50-15	P255/70R17	255/70R18		
P265/70R16	P265/65R17	275/55R18		
P265/75R16	P265/70R17	265/50R19		
245/85R16LT	265/60R17	275/55R19		
265/70R16LT	265/70R17LT	225/70R19.5		
265/75R16LT	265/75R17	245/60R20		
265/80R16LT	275/65R17	265/60R20		
PR78-15	275/65R16LT	305/45R17	3227R	3227CAM
11-15LT	285/60R16LT	P265/60R18		
31X11.50-15LT	32X11.50-16LT	285/60R18		
32X11.50-15LT	33X13.50-16	285/65R18LT		
33X9.50-15LT	34X9-16	285/45R19		
33X13.50-15	12-16.5LT	275/60R20		
34X9.50-15LT	31X10.50-16.5LT	P285/50R20		
PR78-16	285/60R17			
P285/60R16	285/70R17			
275/75R16	265/70R18	275/50R20	3228R	3228CAM
285/75R16LT	P275/60R18	275/45R21		
31X12.50-16	275/65R18			
12-15LT	35X12.5-16	295/70R18LT	3229R	3229CAM
P315/70R15	35X13.5-16	325/60R18		
325/60R15	36X13-16	33X12.5-18		
31X13.5-15	32X12.50-16.5LT	33X13-18		
32X12.50-15	33X12.5-16.5	275/65R20LT		
33X12.50R15	33X15.5-16.5	285/55R20LT		
33X14-15	275/70R17	285/60R20		
33X14.50-15	285/75R17LT	295/55R20		
35X12.50-15	295/70R17LT	305/50R20		
35X14.5-15	305/65R17	305/55R20		
11L16	305/70R17	32X11.50-20		
285/70R16LT	33X12.50-17	33X12.5-20		
295/75R16LT	10.50/80R18	285/50R22		
305/70R16LT	275/70R18LT	33X11.5-22		
305/85R16LT	285/75R18LT			
QR78-15	315/70R17LT	35X12.5-18	3231R	3231CAM
35X13.5-15	325/70R17	285/65R20		
37X13-15	345/55R17	295/65R20		
315/75R16LT	35X12.50-17	325/60R20		
345/55R16LT	37X12.50-17	35X12.50-20		
37X12.50-16	305/60R18	325/50R22LT		
38X13-16	305/70R18LT	35X12.5-22		
38X12.50-16.5	325/65R18	295/60R22.5		

Tractor Chains

Tire Sizes					Stock No.
9.5-24	9.5-28	11.2-24			DUO214
9.5-32	11.2-28	230/95R32	355/80R20		DUO226
10.5/80-18	12-16.5	280/70R20	300/70R20	315/75D15	DUO225
12.4-24					DUO229
9.5-36	9.5-38	11.2-32	12.4-28		DUO218
13.9-36	320/85R34				DUO242
13.6-24	13.6-26	14.9-24			DUO240
14.9-26					DUO250
14.9-28	14.9-30				DUO252
13.6-28	16.9-24	320/85R38	340/85R28	380/85R34	DUO260
14.9-38	15.5-38	320/90R46			DUO254
17.5-24	17.5L-24				DUO263
16.9-26	16.9-28	420/85R28			DUO262
18.4-16.1	21.5L-16.1				DUO264
18.4-24	19.5L-24				DUO268
16.9-30	18.4-26	18.4-28	18.4-30	540/65R30	DUO271
550/65R25	600/65R28				
18.4-34	480/85R34	600/65R25			DUO273
16.9-38	18.4-38	20.8-34	420/80R46	460/85R34	DUO272
480/80R38					
18.4-42	18.4-46	380/90R54	480/80R46		DUO277
20.8-38					DUO276
24.5-32	23.1-34	28.1-34	620/70R42	650/75R32	DUO282



Laclede Snow Blower & Garden Tractor Chains

Tire Sizes		Stock No.
4.00/4.80 x 8		1301G
16 x 6.50 x 8	15 x 6.00 x 6	3300G
18 x 8.50 x 8		3307G
20 x 10 x 8	20 x 10 x 10	7145G
20 x 8.00 x 10	20 x 8 x 8	1308G
23 x 9.50 x 12	23 x 10.50 x 12	5307G

Other sizes available - call for details.

Laclede Forklift Chains

Square link alloy cross chains

Tire Sizes				Stock No.
6.50-10				2108FL
7.50-10	7.00-12	25 x 8.50-14		2110FL
7.00 x 15	28 x 9-15	29 x 8-15	8.15-15	2116FL
27 x 8.50-15	28 x 9.50-15			
7.50-15				2121FL
250-15	27 x 10.50-15			2129FL
8.25-15				2128FL
300-15	28 x 12.50-15			3129FL

Laclede ATV/UTV Chains

- Reinforced cross chain for increased wear and traction
- Two link spacing cross chain

Tire Sizes					Stock No.
24 x 9 x 11	24 x 11 x 11	25 x 10 x 11	25 x 11 x 12	26 x 10 x 12	618
24 x 11 x 9	24 x 11 x 12	25 x 10 x 12	26 x 9 x 12	26 x 10 x 14	
24 x 11 x 10	25 x 8 x 12	25 x 11 x 9	26 x 9 x 14		

Tire Chain Adjusters

Passenger Car No. 29110 Trucks Nos 29925 & 29229

Truck No. 6032

Grader No. 6304

Truck No. 0218

Passenger Car No. 39110 Trucks Nos 39925 & 39229

Ascot No.	Mfg. No.	Description	Qty.
458-29110	29110	Passenger Car - Rubber	2 per bag
458-29225	29225	Light Truck - Rubber	2 per bag
458-29229	29229	Heavy Truck - Rubber	2 per bag
	0218	Spider Truck	2 per bag
458-06302	6302	Light Truck - Spring	1 pair per container
458-06304	6304	Tractor/Grader - Spring	1 pair per container
	39110	Passenger Car - Rubber Arm Blue	2 per bag
	39225	Light Truck - Rubber Arm Grey	2 per bag
	39229	Heavy Truck - Rubber Arm Green	2 per bag

Online Size Lookup



LG Cam Series Available



Grader Chains

Tire Sizes			Tire Chain Stock No.
13.00-24/25	14.00-20/21	15.5-25	2612
14.00-24	14.00-25	400/75R28	2615
16.00-20/21	17.5-25		2624
16.00-24	16.00-25		2627
20.5-25			2633
18.00-25	18.00-24	18.00-26	2636
23.5-25			2645
26.5-25	755/70R25	30.5R32	2657
710/70R38		800/65R32	

Laclede Single Truck Chains

Recommended for highway use • Available in R — regular side chain • Available with cam side chain

Tire Sizes				Non-Cam Stock No.	Cam Stock No.	Weight Per Pair	Cross Chains Per 1/2 Pair	Replacement Cross Chain
10-15TR	11R17.5	9-22.5	275/70R22.5	N/A	2239CAM	44	13	6251
QR78-16	8.25-20	245/75R22.5						
9.00-20	10-22.5	255/80R22.5	265/75R22.5		2241R	46	14	6251
10.00-20	11-22.5	275/80R22.5			2245R	49	15	6251
285/75R22.5	295/75R22.5	305/70R22.5	275/80R24.5	285/75R24.5	2247R	48	14	6253
10.00-22	11-24.5				2249R	53	15	6253
11.00-15TR	11.00-20	12-22.5	12.5-22.5	295/80R22.5	2251R	62	14	6260
12.00-20	13/80R20	11.00-22	315/80R22.5	12-24.5	2255R	67	14	6263

Why studded tires are the best choice for winter driving!

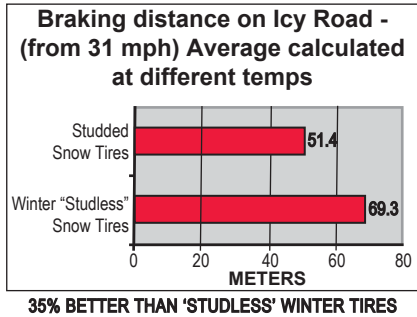

35% BETTER THAN 'STUDLESS' WINTER TIRES

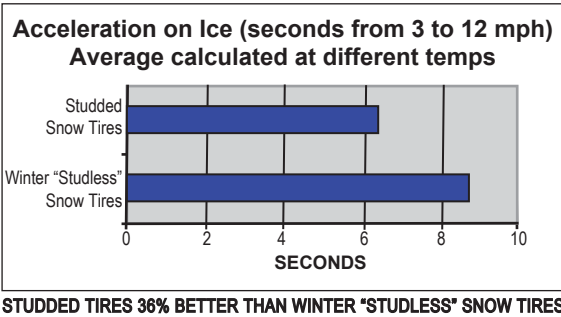

STUDDED TIRES 36% BETTER THAN WINTER 'STUDLESS' SNOW TIRES

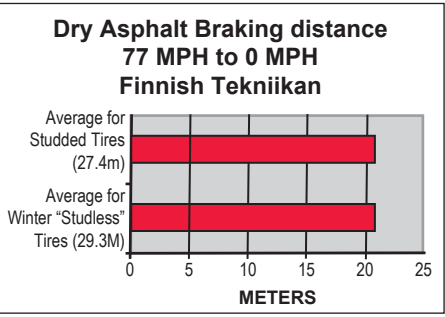

Stud Gun, Studding Equipment

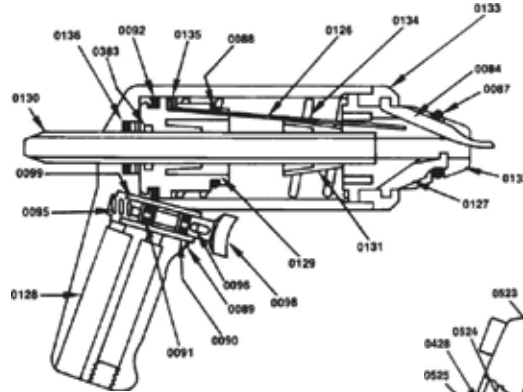

Parts Breakdown



ASCOT NO.	MFG. NO.	DESCRIPTION
458-00010	10G	Stud Gun. Standard of the Industry. Automatic. Light weight.
458-00002	KFP2	Stud Feeder. Fully automatic with 110 Volt motor, fast loading. Provides positive stud orientation. Feeds up to 225 studs per minute.
458-04048	4048	Feederboy Stud Gun. Designed for fast feeding studs of the AS-9 Gun. Attaches with screw clamp. Operates by manually turning the feeder cap.
458-00005	K5	Stud Stand. Saddle, extension for feeder & tray. Welded steel construction. K5M doesn't have tall post.
458-00500	K500	Studding Equipment Kit. INCLUDES: K-5 stand, AS-9 gun, KFP2 automatic stud feeder.

STUD GUN PARTS (AS-9 MODEL)

Part No.	Description
0084	External Finger
0087	O-Ring
0088	O-Ring
0089	O-Ring
0090	O-Ring
0091	O-Ring
0092	Piston Cup
0095	Trigger Spring
0096	Trigger Pin
0098	Trigger
0099	Trigger Sleeve
0126	Pressing Spring
0127	Internal Finger
0128	Handle Body
0129	Piston
0130	Feed Tube
0131	Tapered Sleeve
0132	Head (Steel)
0133	Ring Nut
0134	Compression Spring
0135	Ring
0136	O-Ring
0383	Piston Cup

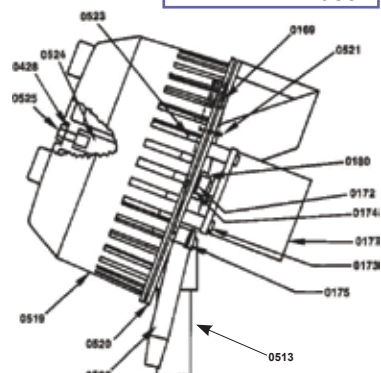

STUD FEEDER PARTS (KFP2 MODEL)

Part No.	Description
0169	Deflector Spring
0172	Snap Ring
0173	Screw
0174	Washer
0175	Clamp
0177	Motor
0180	Drive Shaft Pin
0428	Washer
0513	Clear Tube
0519	Feed Wheel
0520	Base Plate
0521	Retaining Ring
0522	Feed Tube
0523	Screw
0524	Shaft
0525	Hex Bolt

Ugigrip®, Self-Adjusting Carbide Tire Stud

- Delivers full-time traction, increases the safety, convenience and security.
- To order studs to best fit your customers' tire, use the TSMI number recommended by the tire manufacturer



SINGLE FLANGE STUDS:

TSMI Size	11	12	13	15	16	17	19
Overall Length	.345"	.375"	.470"	.520"	.585"	.615"	.635"
Jacket Dia.	.197"	.197"	.197"	.197"	.197"	.197"	.250"
Bottom Dia	.354"	.354"	.354"	.354"	.354"	.354"	.435"
Nearest 32" to Hole Depth	11/32"	12/32"	13/32"	15/32"	16/32"	17/32"	19/32"

Stud Gun Repair & Conversion Kits

ASCOT NO.	GUN	USE WITH STUDS NUMBERED
458-03810	0381	Tire Stud Mini Repair Kit. INCLUDES: (3) 0084 External Fingers; (1) 0087 O-ring; (1) 0088 O-ring; (3) 0126 Pressing Springs
458-03820	0382	Tire Stud Gun Large Repair Kit. INCLUDES: (6) 0126 Pressing Springs; (3) 0084 External Fingers; (2) 0087 O-ring; (2) 0088 O-ring; (1) 0092 Piston Cup; (1) 0136 O-ring
458-00911	0911	AS-9 to AS-11 Conversion Kit. Converts AS-9 Gun to AS-11 Truck model. Includes (1) 0401 Truck Feded Tube, (1) 0400 Truck Stud Gun Head, (3) 0127 Truck Stud Gun Internal Fingers



McGee Company
 1140 South Jason Street
 Denver CO 80223

PRSR STD
 U.S. POSTAGE
PAID
 DENVER, CO
 PERMIT NO 1772

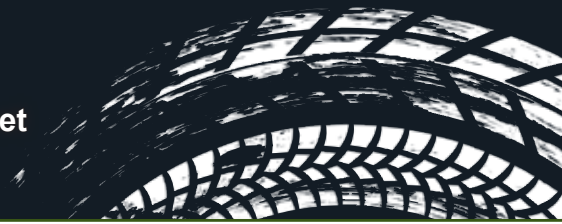

ATTN: ROUTE TO SERVICE DEPARTMENT

©2023 McGee Company, Denver, Colorado

McGeeCompany.com • 1-800-525-8888

C-Series Low Pressure Hose Reels

- Reels ideally suited for plant maintenance, service trucks or other industrial functions
- Standard hose for air and water
- Single set screw to access spring casing
- Drive spring mechanism lubricated for life
- One piece combination latch, spring arbor, main bearing and spool support for fewer moving parts
- Brass swivel reduces corrosion potential
- Durable powder coated finish



HOSETRACT



Made in the USA

Ascot No.	McGee No.	Operating Pressure	Hose ID	Hose Length	Ship Weight	Price
125-35000	LC350	300 psi	3/8"	50'	54 Lbs.	\$342.86
125-55000	LC550	300 psi	1/2"	50'	60 Lbs.	\$385.71

How much are you leaving on the table by not doing service kits and TPMS?

→ MOST ARE MADE IN THE USA ←



More TPMS info on pages 2-4

CALCULATE YOUR PROFIT



Graco Oil King

- Large 25 gallon capacity with sight gauge
- Convenient tool trays and filter areas
- Large offset collection pan with screen
- Oversized tires to get over hose and rough floors



238866 — Now! \$655*
 *Valid until 1/1/24

Splatter pads available!

GRACO QUALITY!

Rhino Tuff Tanks

- Fluid Dispenser Compatible
- Stackable
- Caged Options



**Are you ready?
 EV Chargers Available by Autel**

Ask about our other EV related TPMS, Lifts, and Diagnostic tools.

