

Why studded tires are the best choice for winter driving!

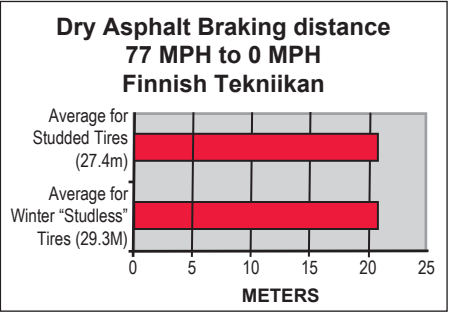

Stud Gun, Studding Equipment

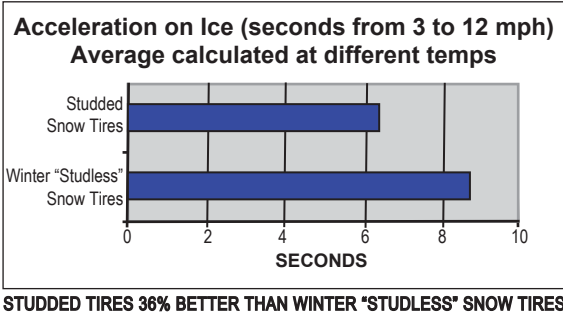
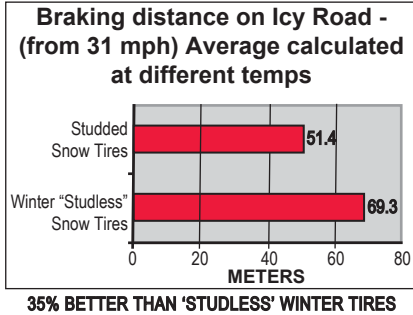
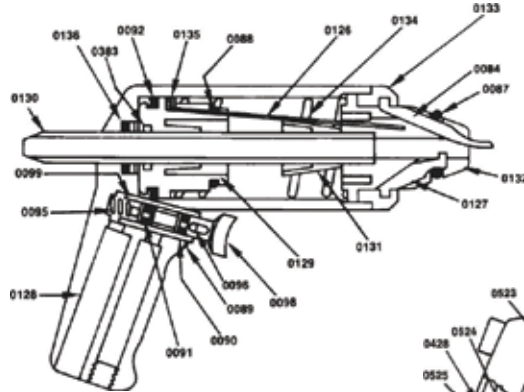

Parts Breakdown



ASCOT NO.	MFG. NO.	DESCRIPTION
458-00010	10G	Stud Gun. Standard of the Industry. Automatic. Light weight.
458-00002	KFP2	Stud Feeder. Fully automatic with 110 Volt motor, fast loading. Provides positive stud orientation. Feeds up to 225 studs per minute.
458-04048	4048	Feederboy Stud Gun. Designed for fast feeding studs of the AS-9 Gun. Attaches with screw clamp. Operates by manually turning the feeder cap.
458-00005	K5	Stud Stand. Saddle, extension for feeder & tray. Welded steel construction. K5M doesn't have tall post.
458-00500	K500	Studding Equipment Kit. INCLUDES: K-5 stand, AS-9 gun, KFP2 automatic stud feeder.

STUD GUN PARTS (AS-9 MODEL)

Part No.	Description
0084	External Finger
0087	O-Ring
0088	O-Ring
0089	O-Ring
0090	O-Ring
0091	O-Ring
0092	Piston Cup
0095	Trigger Spring
0096	Trigger Pin
0098	Trigger
0099	Trigger Sleeve
0126	Pressing Spring
0127	Internal Finger
0128	Handle Body
0129	Piston
0130	Feed Tube
0131	Tapered Sleeve
0132	Head (Steel)
0133	Ring Nut
0134	Compression Spring
0135	Ring
0136	O-Ring
0383	Piston Cup

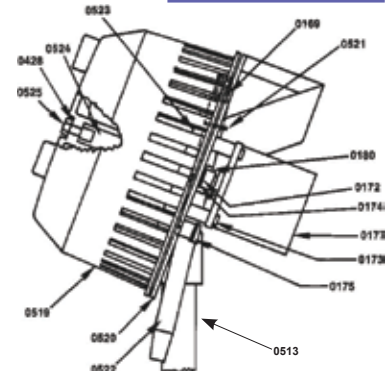

STUD FEEDER PARTS (KFP2 MODEL)

Part No.	Description
0169	Deflector Spring
0172	Snap Ring
0173	Screw
0174	Washer
0175	Clamp
0177	Motor
0180	Drive Shaft Pin
0428	Washer
0513	Clear Tube
0519	Feed Wheel
0520	Base Plate
0521	Retaining Ring
0522	Feed Tube
0523	Screw
0524	Shaft
0525	Hex Bolt

Ugigrip®, Self-Adjusting Carbide Tire Stud

- Delivers full-time traction, increases the safety, convenience and security.
- To order studs to best fit your customers' tire, use the TSMI number recommended by the tire manufacturer



SINGLE FLANGE STUDS:

TSMI Size	11	12	13	15	16	17	19
Overall Length	.345"	.375"	.470"	.520"	.585"	.615"	.635"
Jacket Dia.	.197"	.197"	.197"	.197"	.197"	.197"	.250"
Bottom Dia	.354"	.354"	.354"	.354"	.354"	.354"	.435"
Nearest 32" to Hole Depth	11/32"	12/32"	13/32"	15/32"	16/32"	17/32"	19/32"

Stud Gun Repair & Conversion Kits

ASCOT NO.	GUN	USE WITH STUDS NUMBERED
458-03810	0381	Tire Stud Mini Repair Kit. INCLUDES: (3) 0084 External Fingers; (1) 0087 O-ring; (1) 0088 O-ring; (3) 0126 Pressing Springs
458-03820	0382	Tire Stud Gun Large Repair Kit. INCLUDES: (6) 0126 Pressing Springs; (3) 0084 External Fingers; (2) 0087 O-ring; (2) 0088 O-ring; (1) 0092 Piston Cup; (1) 0136 O-ring
458-00911	0911	AS-9 to AS-11 Conversion Kit. Converts AS-9 Gun to AS-11 Truck model. Includes (1) 0401 Truck Feded Tube, (1) 0400 Truck Stud Gun Head, (3) 0127 Truck Stud Gun Internal Fingers

MADE IN FRANCE FOR OVER 50 YEARS!