



Cylinder and Seal Kit Replacement Guide

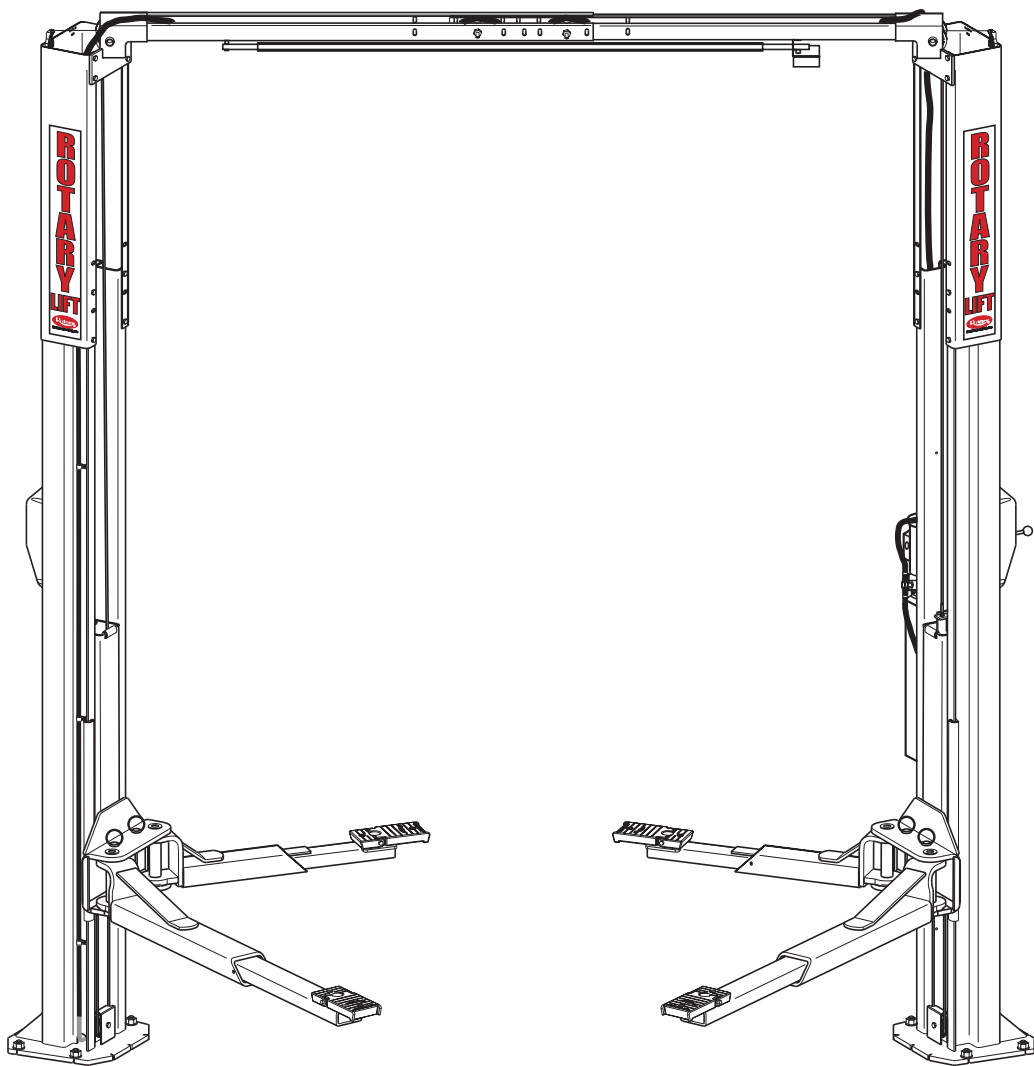

TABLE OF CONTENTS

*Cylinder Trouble Shooting on "SP" Series Lifts	3
*Assembly Instructions For Kit #FJ7375	5
*FJ592 Cylinder Bleeder Replacement Kit	6
*Exploded View of Cylinder (Sample)	7
*2-Post Cylinder Manufacturers Guide	7
2-Post Cylinder Guide	8
4-Post Cylinder Guide	12
Low/Mid Rise Cylinder Guide	17
Rolling Jack Cylinder Guide	20
* NOTE: Pages 3-7 describe 2-Post cylinders but may be applied to other cylinder types shown in booklet.	

Cylinder Trouble Shooting On "SP" Series Lifts

- 1) Customer complaint: Fluid leaking and/or accumulating around base of lift.
- 2) Possible causes:
 - A) Oil on floor due to causes other than leaks at lift.
 - B) Fitting at base of cylinder leaking.
 - C) Manual bleeder leaking.
 - D) Cylinder leaking from seal.
 - E) Leaks oil from breather.
 - F) Hose leaking or weeping.

How to Check Hydraulic System

- 1) Clean all oil points.
- 2) Raise lift all the way up and hold it under pressure for 10 seconds.
- 3) Relieve pressure at lowering valve.
- 4) Check all possible leak points.
- 5) If leaks are found, determine the extent of repair needed.

If The Cylinder Is leaking From Seal

*****Before removing cylinder make sure you have the correct seal kit.*****

Double "S" Formed Column Lifts.

Cylinder Removal Procedure

- 1) Loosen the equalizer cable on the opposite carriage.
- 2) Raise the lift to the top and rest the carriage on the top latch position.
- 3) Check to make sure the carriage is secure on latches.
- 4) Make sure the pressure has been relieved from the system.
- 5) Follow the proper LOCKOUT/TAGOUT procedures for disconnecting power to lift.
- 6) Remove the lower sheave cover at base of column.
- 7) With lowering valve depressed, manually pull cylinder down out of carriage.
- 8) Disconnect the swivel hose fitting at base of cylinder.
- 9) Cap hose ends and cylinder adapter to prevent fluid loss.
- 10) Carefully remove cylinder from column.

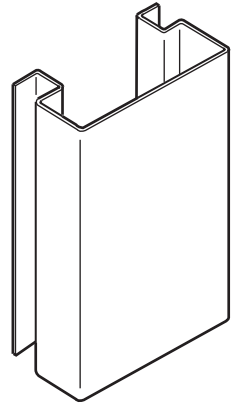

Cylinder Rebuilding

*****Kit has only enough parts for (1) cylinder.*****

- 1) Remove manual bleeder and extend plunger from casing.
- 2) Remove piston retaining ring or clip.
- 3) Remove plunger from casing.
- 4) Clean inside of casing, making sure all debris is removed with mineral spirits.
- 5) Inspect seal for damage.
- 6) Replace seal and all other components (wiper, wear ring, etc.).
- 7) Coat seal with oil or white grease.
- 8) Reinstall plunger, retaining ring, and manual bleeder being careful not to scratch or dent plunger surface.

Cylinder Replacement

- 1) Reinstall cylinder and reconnect hose fitting.
- 2) Reconnect power source.
- 3) Install lower sheave cover.
- 4) Raise cylinder in column through the carriage lifting plate and cylinder centering bar.
- 5) Lower both carriages.
- 6) Adjust equalizer cables.
- 7) Carefully raise carriages about two feet. Bleed air from both cylinders.
- 8) Fully lower lift.
- 9) Check and add fluid as necessary.
- 10) Raise lift to full rise and check for leaks.
- 11) Tag lift back in service.

SP84, SPOA84, SP94, Series Lifts

Cylinder Removal Procedure

- 1) Raise the lift about 2'-0". Open manual bleeder in top of both cylinders to bleed off any air pockets. Close bleeder when fluid appears. Lower lift.
- 2) Remove arm pins and swing arms.
- 3) Disconnect both cables at upper tie-off.
- 4) Manually lift carriage to its top locking position. Let carriage rest on latch. Place a suitable support under carriage.
- 5) Remove the upper cable sheave bracket. (Also column extensions on SPO models.)
- 6) Disconnect hydraulic line and unscrew adapter at the cylinder base.
- 7) Remove 1/4" x 4-1/2" HHCS at base of cylinder.
- 8) Manually lift carriage until upper rollers or slider blocks start to protrude above column.
- 9) Angle cylinder out of column through front opening and lower carriage back in top latch position.

Cylinder Rebuilding

- 1) Using a spanner wrench or other suitable tool, turn cylinder casing clockwise, until straight end of retainer ring is located in the mill slot on the cylinder casing.
- 2) Insert screwdriver under beveled edge of retainer ring.
- 3) Turn casing head counterclockwise until retainer ring is removed.
Note: If cylinder is laying horizontally, place oil pan under cylinder head area before casing head is removed.
- 4) Remove casing head.
- 5) Open manual bleeder vent at top of cylinder and remove entire plunger from cylinder casing and inspect for nicks, scratches, etc.
- 6) Install new seal kit.
- 7) Apply a generous coating of Dexron III ATF on new seal kit components.
- 8) Insert plunger in cylinder, being careful not to scratch finish.
- 9) Insert cylinder casing head and line up retainer ring slot with mill slot in cylinder casing.
- 10) Insert bent end of retainer ring into slot.
- 11) Turn casing head clockwise until retainer ring is completely inside casing.
- 12) Close the manual bleeder valve.

Cylinder Replacement

- 1) Install hex adapter on new cylinder.
- 2) Again, manually lift the carriage and insert cylinder in the column.
- 3) Lower carriage to top locking latch position.
- 4) Secure cylinder in column and replace 1/4" bolt.
- 5) Reinstall upper sheave bracket.
- 6) Reconnect hydraulic line.
- 7) Lift carriage off locking latch and position latch arm to disengage the latch.
- 8) Lower carriage to floor.
- 9) Reconnect cable to upper cable tie-off. BE SURE cables are roped through sheave rollers.
- 10) Raise lift about 2'-0" and open manual bleeder in top of cylinder. Close when fluid appears.
- 11) Remove filler breather cap from power unit and refill reservoir with Dexron III, ATF.
- 12) Raise lift to full travel and adjust tension on cables. Grasp cables between thumb and forefinger. With about 15lbs. tension, you should just pull the cables together.
- 13) Tighten cable jam nut on upper cable tie-off stud.
- 14) Lower lift and reassemble arms and pins.
- 15) Raise lift to full travel and check pipe joints for leaks.
- 16) The lift should now be ready for use.

Revolution Lifts RTP10

Cylinder Removal Procedure

- 1) With lift in the fully lowered position raise lift to first locking position.
- 2) Lower lift to first locking position
- 3) Remove 1 1/8" cylinder jam nut and retaining nut from the bottom of the carriage.
- 4) Cut and remove plastic hose ties from cylinder.
- 5) Disconnect hydraulic hose from elbow at cylinder
- 6) Cap off cylinder elbow with 9/16 JIC cap and Hose with 9/16 JIC plug.
- 7) Remove nut and bolt from overhead side of cylinder * Note when this bolt is removed, nothing will be holding the cylinder*
- 8) Remove hydraulic cylinder from column.

Cylinder Reinstallation

- 1) Inspect cylinder to insure C-clip is installed at rod end of cylinder
- 2) Place cylinder in column and reinstall overhead cylinder bolt and nut.
- 3) Manually pull chrome plunger rod down into the carriage placing the threaded end into hole at the base of the carriage.
- 4) Reinstall 1 1/8 cylinder retaining nut and jam nut on cylinder rod at underside of the carriage.
- 5) Raise lift off locks using lifts power unit.
- 6) Lower lift to floor level
- 7) Check hydraulic oil level at power unit reservoir and add fluid as needed.
- 8) Cycle lift several times to bleed air from lift cylinders
- 9) With lift in lowered position, check oil level and add fluid as needed.

Assembly Instructions For Kit #FJ7375 (To replace FJ783 Cylinder)

1. Lubricate "O" Rings on Reducer and expander fittings and install reducer into supplied cylinder FJ7211. (Fig. 2)
2. Install expander into reducer. (Fig. 2)
3. Clean supplied adapter FJ7353-2. Back nut away from groove in fitting. Push washer back to end of groove.
4. Push "O" ring back to washer. Lubricate "O" ring.
5. Screw fitting into expander until the washer contacts fitting. (Fig. 2)
6. Turn fitting counter clockwise less than one turn to lineup 1/4" pipe port (Fig 1). Hold fitting and tighten nut to 35-40 foot-pounds torque.
7. There is a mix of restricted and nonrestricted cylinders serviced by kit #FJ7375. Lift performance can be affected when nonrestricted and restricted cylinders are utilized on opposite sides of a lift. This kit contains adapters which have a restrictive feature built in to equalize cylinder rate of travel. Identification of cylinders are found as shown in figure 3. All FJ783 cylinders require restricted adapter FJ7757. All FJ7211 cylinders supplied by Texas Hydraulics with a date code prior to 168 Require a FJ7755 adapter. All FJ7211 cylinders supplied by Pacoma with a code prior to 3401529M96 require a FJ7755 adapter. Check the code on all cylinders and assemble appropriate adapter into the cylinder not being replaced to insure all cylinders are restricted.

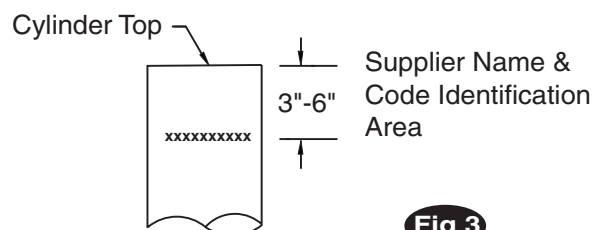
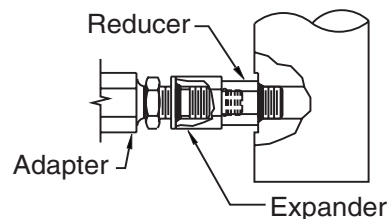
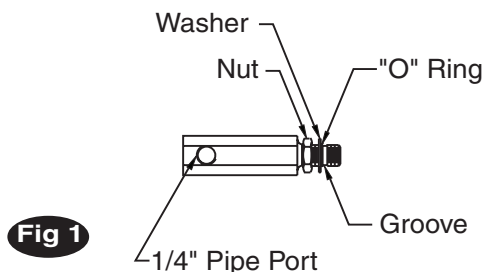

FJ592 Cylinder Bleeder Replacement Kit Installation Instructions

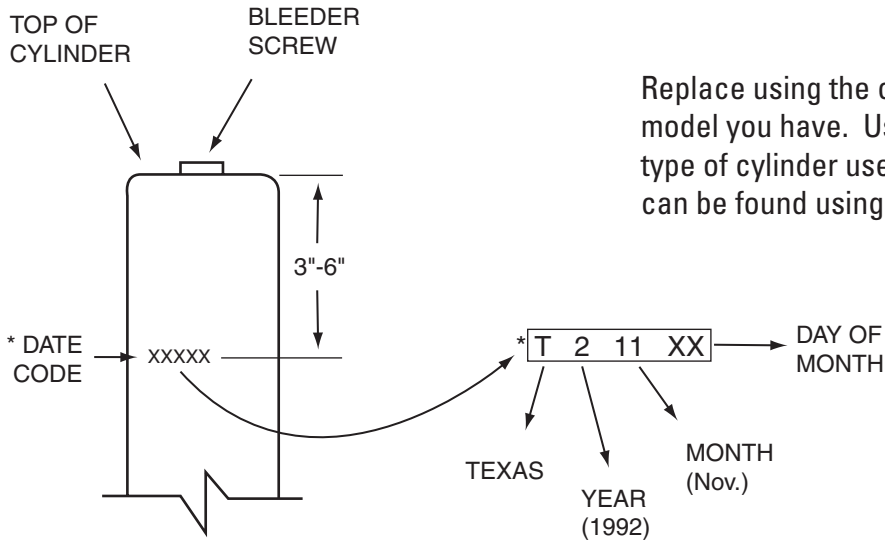

Bleeder Screws For Texas Hydraulics Cylinders

Part No#. 32516 - Date code T211XX & after (Nov. 92)
 Consists of: Part No# 32326 Screw & Part No# 14525 O-Ring Washer

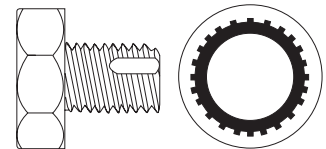

Bleeder Screws For Pacoma Cylinders

Part No#. 3443881 MI - All cylinders used the same screw.

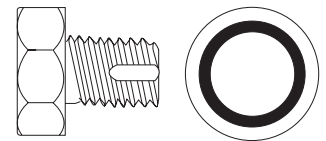

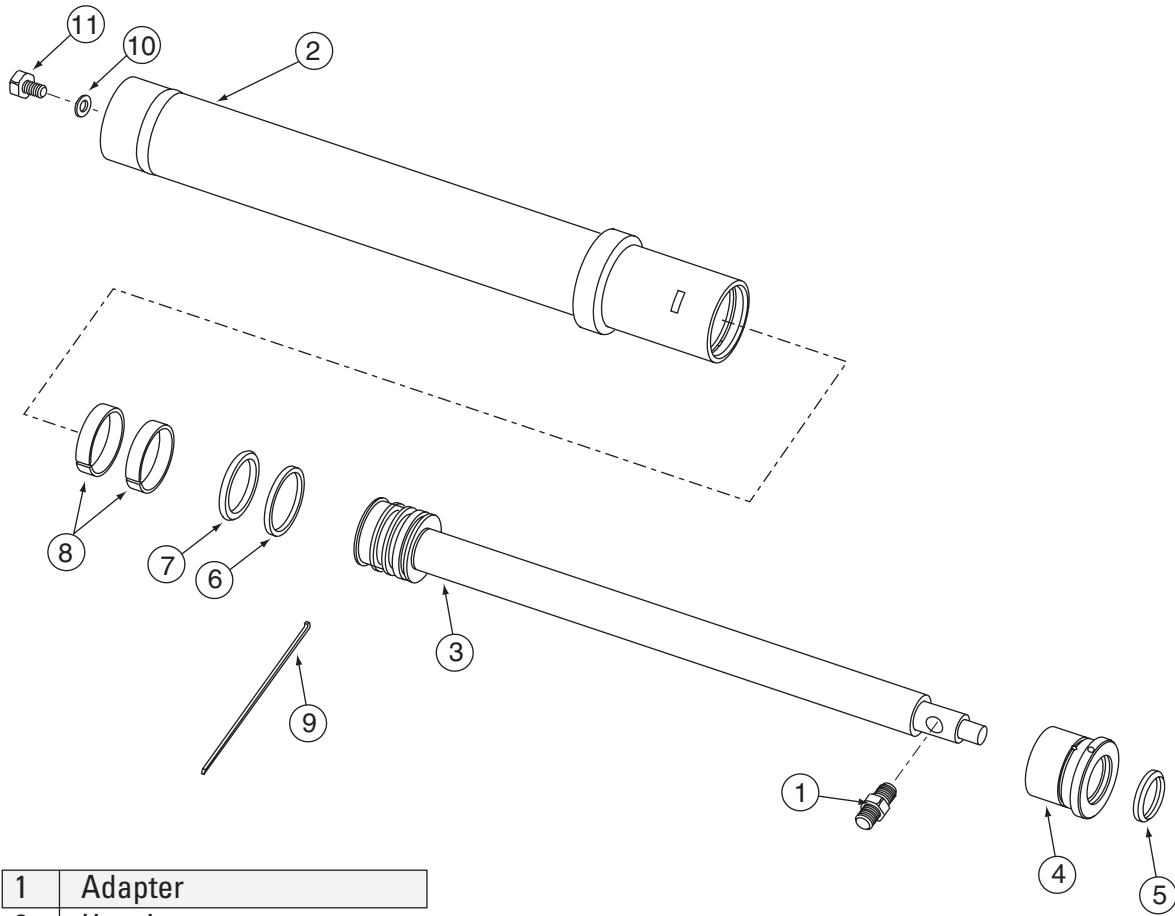

1	Adapter
2	Housing
3	Piston Rod
4	Bushing Guide
5	Felt Wiper
6	Felt Ring
7	Seal
8	Guide Ring
9	Retainer Wire
10	Seal
11	Bleeder Plug



World Leader in Lift Systems

2-Post Cylinder Guide

PB 10-4-1

Cylinder Kit Identification Table 2-Post Surface and Inground Lifts (SL Models)

Lift Model	Original Cylinder	Replacement Cylinder	Seal kit
SP70, SP74	FJ76	N/A	FJ76-12
SP80 Thru -3 SP84 Thru -7	FJ720	N/A	FJ720-12 *FJ720-30
SP55, SP80-4, SP80-5, SP84-8 Thru 11, SP84-16, SPO84, SPOA84, AR94, ARO94, SP94, SPO94,	FJ7211 FJ783	FJ7375	**FJ783-12TH **FJ783-12MF ***FJ783-12UK
SP88, SPO88,SPOA88, SP98, SPO98, SPOA98, DCOA7, SPO82, AR98, ARO98	FJ7311	FJ7311	**FJ783-12TH **FJ783-12MF ***FJ783-12UK
WOA83, SP7, SP9, SP07, SP09 Thru -200, SPOA7 Thru -200, SPOA9 Thru -200, TLO7 Thru -200	FJ7664	FJ7664	**FJ783-12TH **FJ783-12MF ***FJ783-12UK
SPA7LC, SPOA7LC	FJ7606	FJ7606	FJ7606-12TH
SPOA7LC-300	N352	N353	N352-12MF
SPOA7LC-400, SPOA10-500, SPO10-500	N353	N353	**N342-12 (Pacoma) **N342-13 (Panni)
SPOA7-300 Thru -400, SPOA9-300 Thru -700, SPO9-300 Thru -700, SPOA10-300 Thru -700, TLO7-300 Thru -500 SPO12-310 Thru -710	N342	N380	**N342-12 (Pacoma) **N342-13 (Panni)
SPOA7-300 Thru -700, SPOA9-300 Thru -700, SPO9-300 Thru -700, SPOA10-300 Thru -700, TLO7-300 Thru -500, SPO12-310 Thru -710 Extended rise 71" rise	N382 N343	N347	**N342-12 (Pacoma) **N342-13 (Panni)
SPO10-400 Thru -500, SPOA10-400 Thru -500.	N346	N346	**N342-12 (Pacoma) **N342-13 (Panni)
SPO10-500 Thru -700, SPOA10-500 Thru -700.	N380 N380Y	N380E N380Y	**N342-12 (Pacoma) **N342-13 (Panni) **N380Y-9180 (United Hyd)
SPO12, SPO15, SPO18	FJ7604	FJ7604	**FJ7604-12TH **FJ7604-12HP
SPO12-10	N310	****N310KIT	**FJ783-12TH **FJ783-12MF

* FJ720-30 for both Best & Texas Hyd Cylinders

** Rotary Lift had different cylinder suppliers for these cylinders. To identify the correct seal kit, observe to markings in the casing aprox. 6" from the bleeder screw. The word Pacoma indicates MF seal kit. The letters T, TX, TXT or no marking indicates the TH seal kit or United Hydraulics

*** Kit contains both FJ783-12TH & FJ783-12MF seal kits

**** N310 is an FJ7664 with adapters and flow control

FJ720 Cylinder

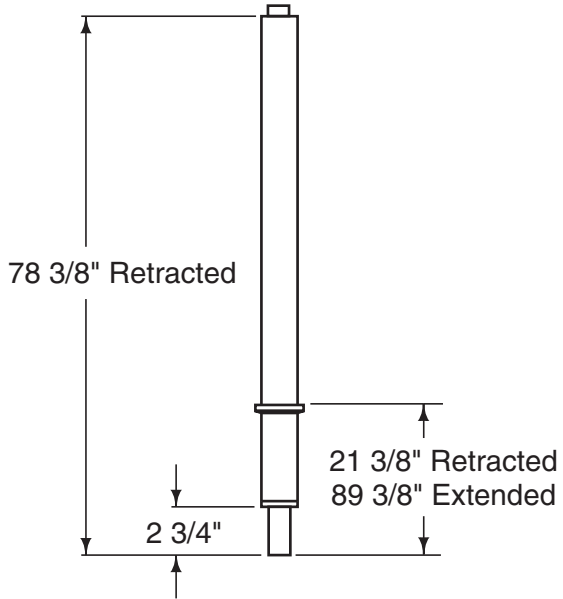

FJ7375 Kit/FJ7211 Cylinder

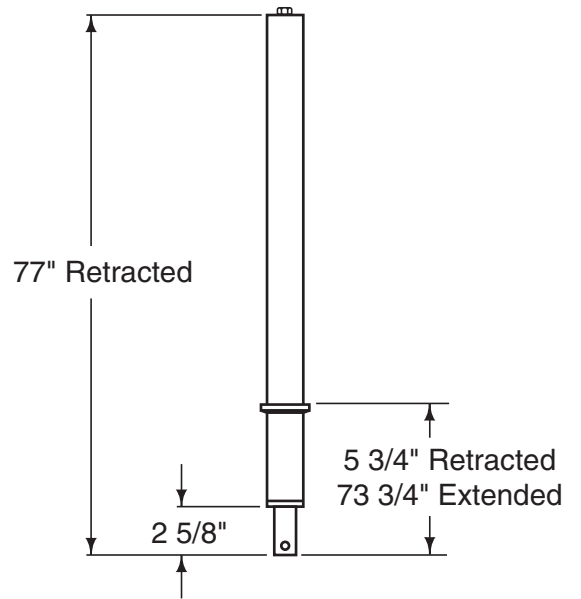

FJ7311 Cylinder

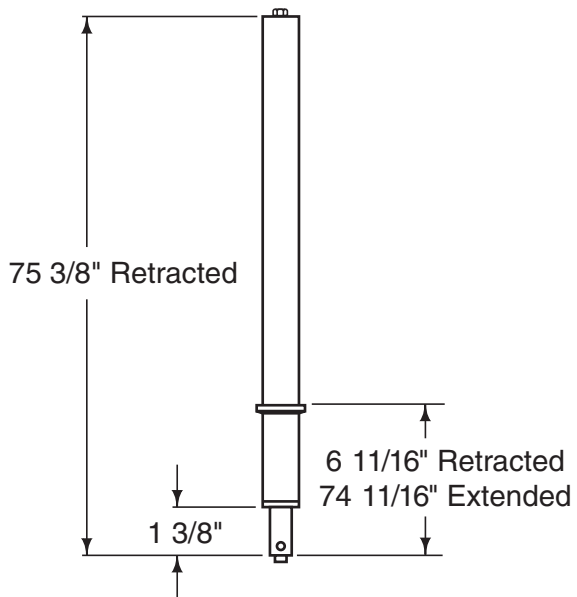

FJ7604 Cylinder

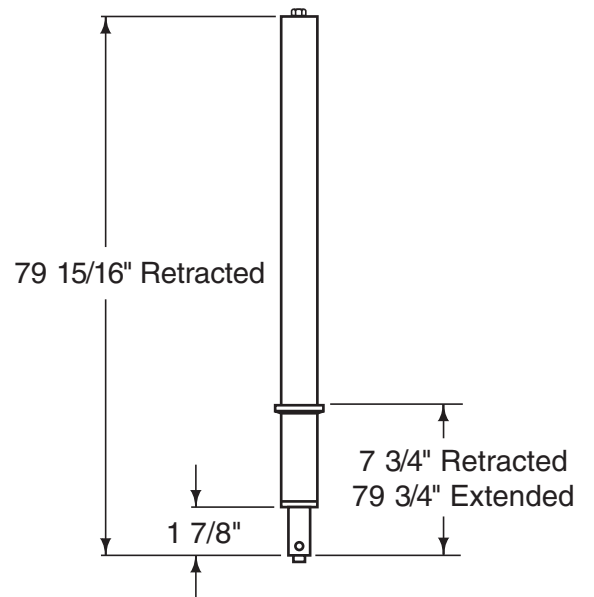

FJ7606 Cylinder

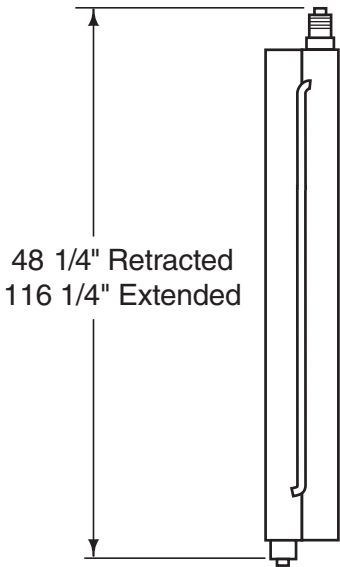

FJ7664/N310 Cylinder

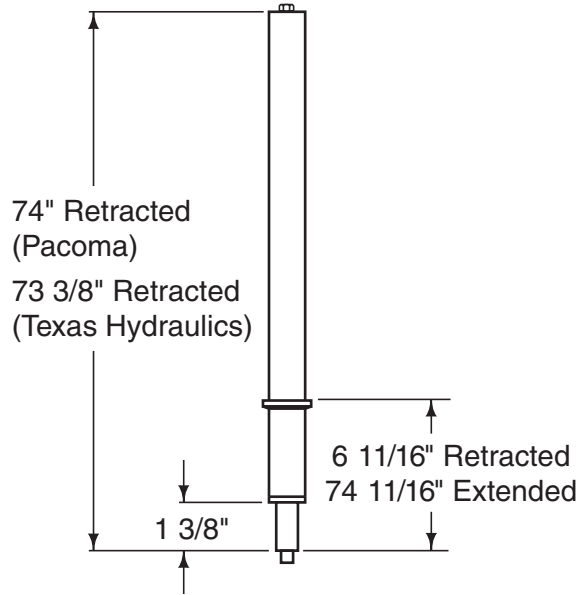

N380e Cylinder

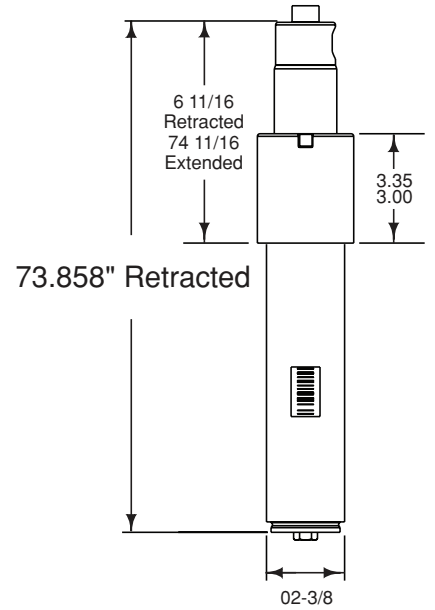

FJ783 Cylinder

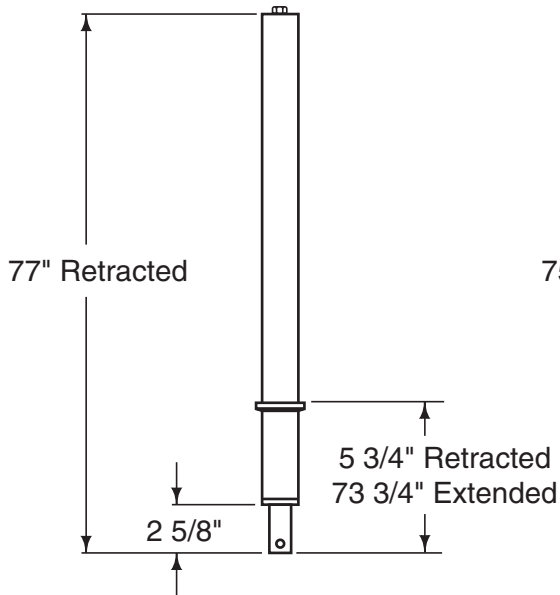

FJ76 Cylinder

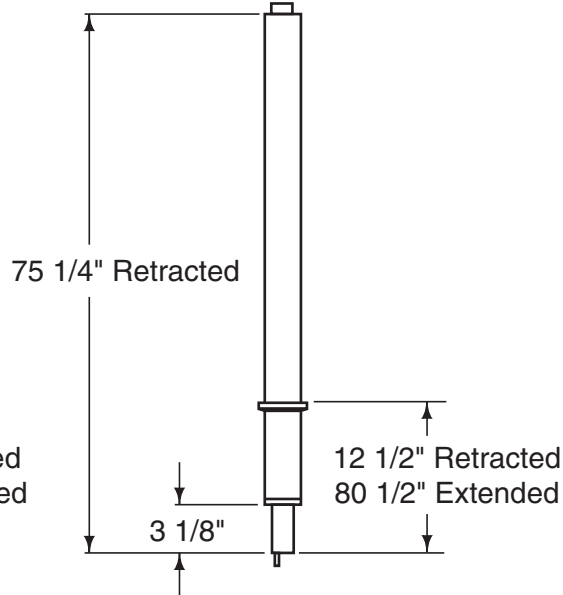

N380y Cylinder

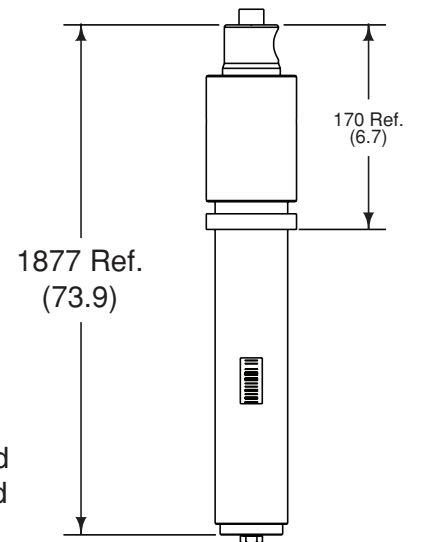



World Leader in Lift Systems

4-Post Cylinder Guide

PB 10-4-2

Cylinder Kit Identification Table

4-Post Lifts

Lift Model	992304	Replacement Cylinder	Seal kit
SM7	S130093 (94" Stroke) S130095 (77" Stroke)	S130093 S130095	S130093-12
SM90, AR90, CWA90, SM91, AR91	FC5343 (Clevis) FC537 (Bracket)	NLA FC537KIT	*FC537-12T *FC537-12MF
SM101	FC5342	FC5797-1	*FC542-12TH *FC542-12MF
SM120, AR120, CWA120, SM121, AR121, QL4P, QLHV	FC5342 (Clevis) FC542 (Bracket)	FC5797-1 FC542-KIT	*FC542-12TH *FC542-12MF
SM122, AR122, SMO123, ARO122, QL4P-100 QLHV-100, SM101-100	FC5797 FC5342	FC5797-1 FC5797-1	FC5797-TH-UNI *FC542-12TH *FC542-12MF
SM123, AR123, SMO123, ARO123, SM12, AR12, QL4P- 200, QL12	S130002	S130002	FC5797-TH-UNI **S130002-12HY **S130002-12PC
SM14, AR14,	S130002	S130002	FC5797-TH-UNI **S130002-12HY **S130002-12PC
SMO14, ARO14	S130156	S130156	**S130002-12HY **S130002-12PC
SM180, SM181, SM18	FC5810-38	FC5810-38	FC5810-38-12TH
SM300, SM250, SM270, FLS25	FC5225-15	FC5225-15	FC5225-70
SM300, SM500, SM600	FC5761	FC5761	FC5761-12TH
FLS12, FLS15	FC5155	FC5155	FC5155-10
12000LRT (Mez)	992302	992302	992302SKAA
40000HDL, 50000HDL	992304	992304	992304SKAA
60000HDL	992326	992326	
Scissor / Parallelogram (Light Duty)			
ARP70	FC86	NLA	FC86-12TH
GLP35-100	40-0604 (P1 Cyl.) 40-0605 (P2 Cyl.)	40-0604 (P1 Cyl.) 40-0605 (P2 Cyl.)	04L7173 (P1) 04L7173 (P2)
SC9i	XS130008	XS130008	XS130138
YA12	Z140039Y	Z140039Y	Z140039Y-12
Parking Lift			
VSS7-000 & -010	PS130004	PS130004	*PS100008TH *PS100008MF
VSS7-001 & -011	PS130004	PS130004	*PS100008TH *PS100008MF

* Rotary Lift had different cylinder suppliers for these cylinders. To identify the correct seal kit, observe to markings in the casing. The word Pacoma indicates MF seal kit. The letters T, TX, TXT or no marking indicates the TH seal kit.

**Hyko Cylinder

How To Determine Cylinder Manufacturer:

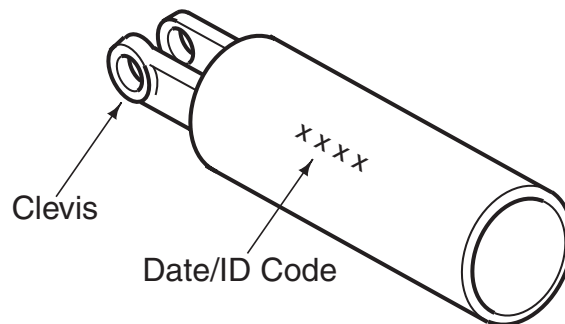

Notes:

- Look all the way around the cylinder tube on the clevis or pressure port end for markings.
- Texas Hydraulic cylinders will be identified by a "TX" followed by a four digit date code stamped on the cylinder. In some cases the Rotary part number will be stamped above the date code.
- Pacoma cylinders will have "Pacoma" stamped on them.

FC5343 Cylinder

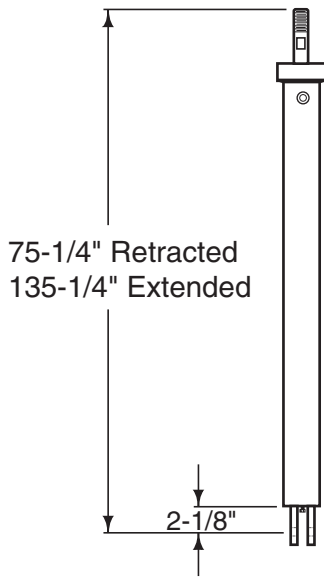

FC537 Cylinder

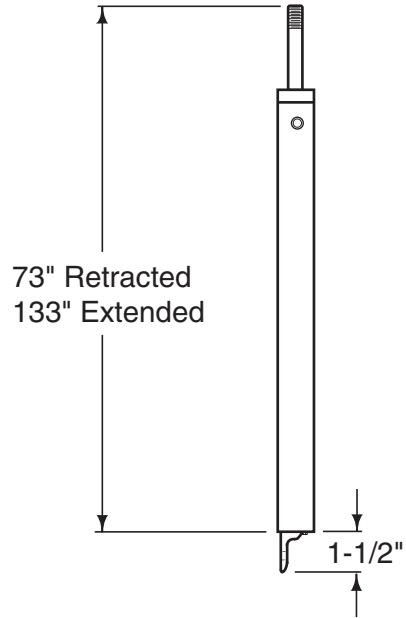

FC5797 Cylinder

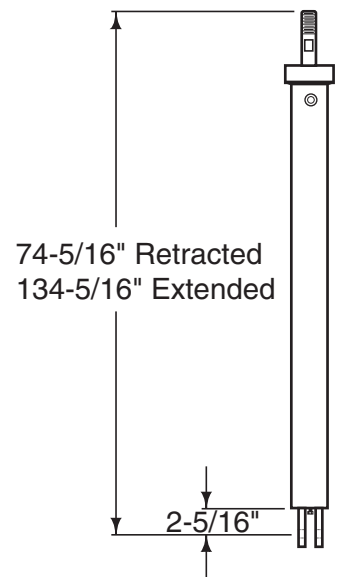

FC5155 Cylinder

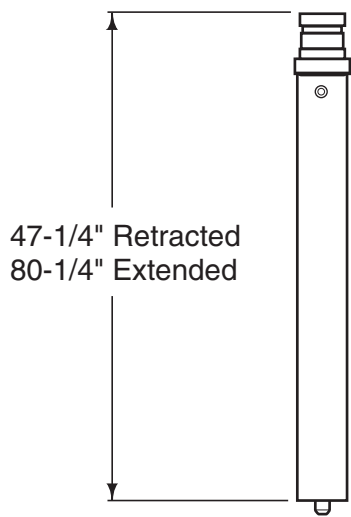

FC5761 Cylinder

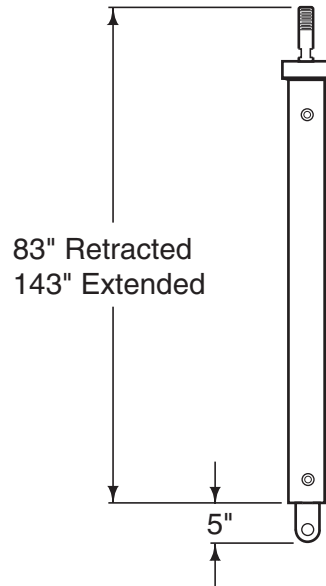

FC5225-15 Cylinder

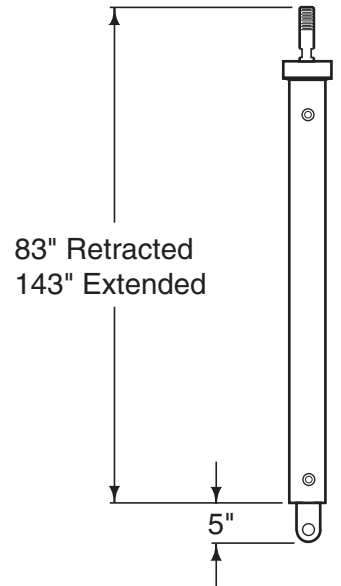

FC5810-38 Cylinder

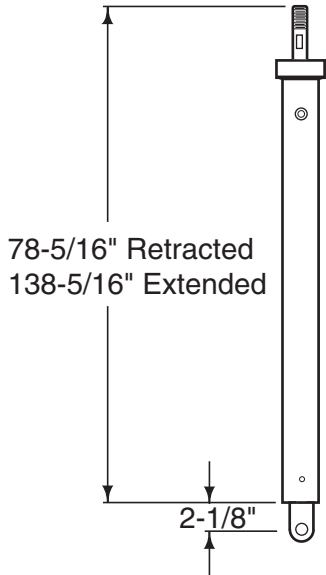

S130156 Cylinder

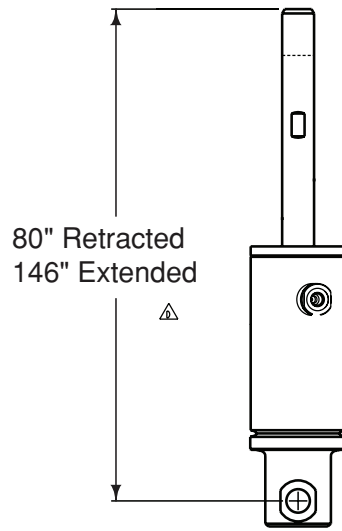

992326 Cylinder

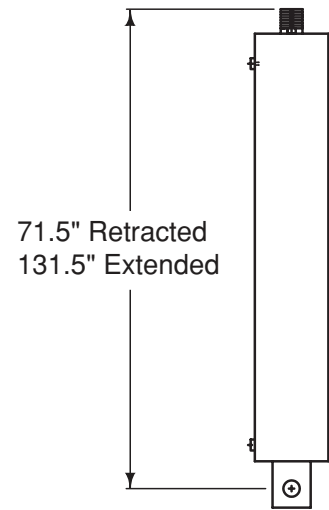

992302 Cylinder

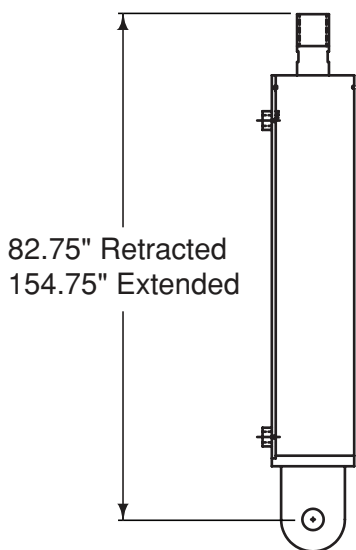

PS130004 Cylinder

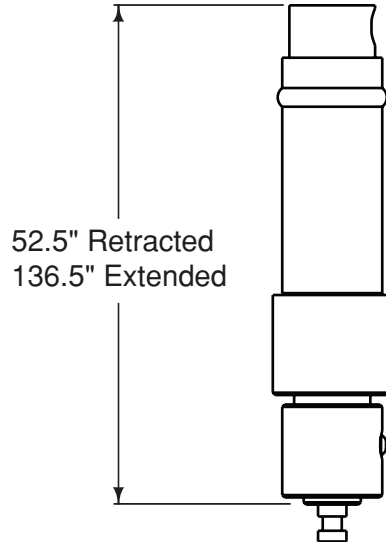

S130002 Cylinder

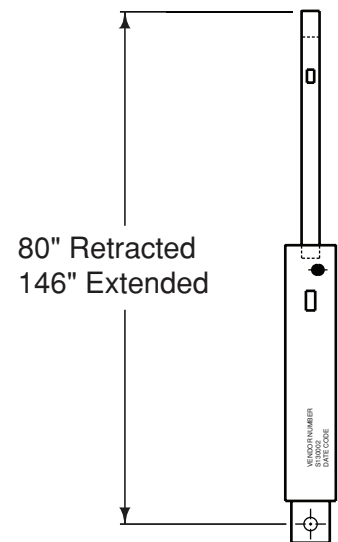



World Leader in Lift Systems

***Low/Mid Rise
Cylinder
Guide***

PB 10-4-3

Cylinder Kit Identification Table

Low/Mid Rise

Lift Model	Original Cylinder	Replacement Cylinder	Seal kit
PAL4, PAL5E	FJ253-3	NLA	NLA
PAL-5E	FJ294-3	NLA	FJ294-3-12MF
PAL7, PFX, MPFX, PSL6, VLX6, VLXS6, VL6, VLS6, VLD6	FJ2248	FJ2248	*FJ2248-12TH *FJ294-3-12MF
PFX-1, PAL6	FJ2173	NLA	*FJ2248-12TH *FJ294-3-12MF
MPAL8	FJ2263	FJ2263	*FJ2248-12TH *FJ294-3-12MF
MR6, VM6, VMP6, VMP6A, VMR6	FJ860	FJ860	FJ860-12TH
VLXS7, VLXS10	992305	992305	**991513 (Texas) **992305SKAA (Arlington) **YG42-9180

* Rotary Lift had different cylinder suppliers for these cylinders. To identify the correct seal kit, observe to markings in the casing. The word Pacoma indicates MF seal kit. The letters T, TX, TXT or no marking indicates the TH seal kit.

**Used three different cylinder Mfg. Look for markings on the cylinder. If no markings use YG642-9180 seal kit.

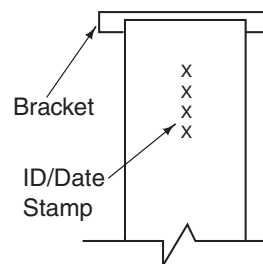

How To Determine Cylinder Manufacturer:

- Look all the way around the cylinder tube on the clevis or pressure port end for markings.
- Texas Hydraulic cylinders will be identified by a "TX" followed by a four digit date code stamped on the cylinder. In some cases the Rotary part number will be stamped above the date code.
- Pacoma cylinders will have "Pacoma" stamped on them.
- North Carolina cylinders are stamped "North Carolina".
- Duke cylinders have a snap ring at the rod end.

Seal Replacement:

When replacing seals on lift models PAL4 and PAL5 use only seal kit FJ2248-12. All later PAL, MPAL, MPFX, and PFX models can use either seal kit FJ2248-12 or FJ294-3-12.

FJ2248 Cylinder

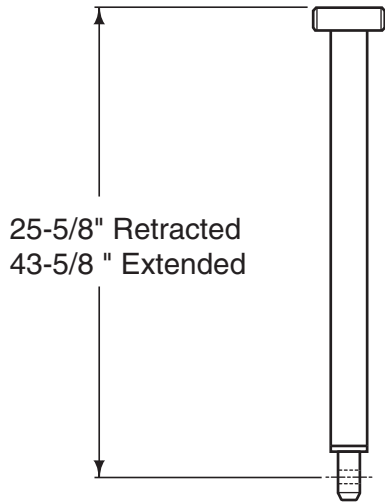

FJ860 Cylinder

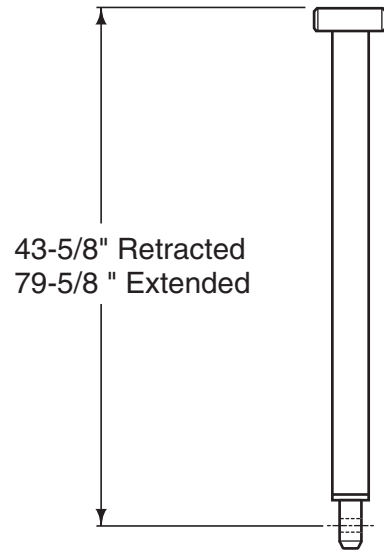

FJ2263 Cylinder

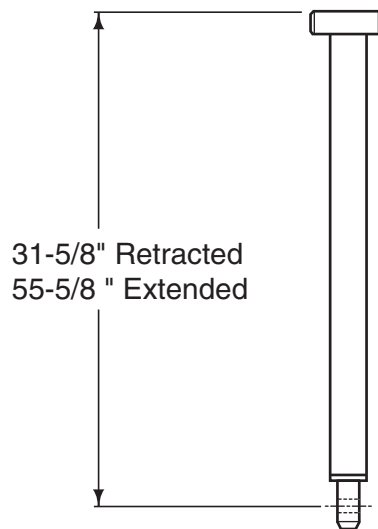



World Leader in Lift Systems

Smart Lift Cylinder Guide

Lift Model	Original Cylinder	Replacement Cylinder	Seal kit
SL19	FJ7604	FJ7604	**FJ7604-12TH **FJ7604-12HP
SL28, SL9, SL29 Thru -200	FJ7664	FJ7664	**FJ783-12TH **FJ783-12MF
SL29-300	N342 N380	N380 N380	**N342-12 (Pacoma) **N342-13 (Panni)
SL29-400 Thru -800 SL212-400 Thru 1000	N367	N367	N342-12
** Need to ID cylinder for correct kit			

FJ7604 Cylinder

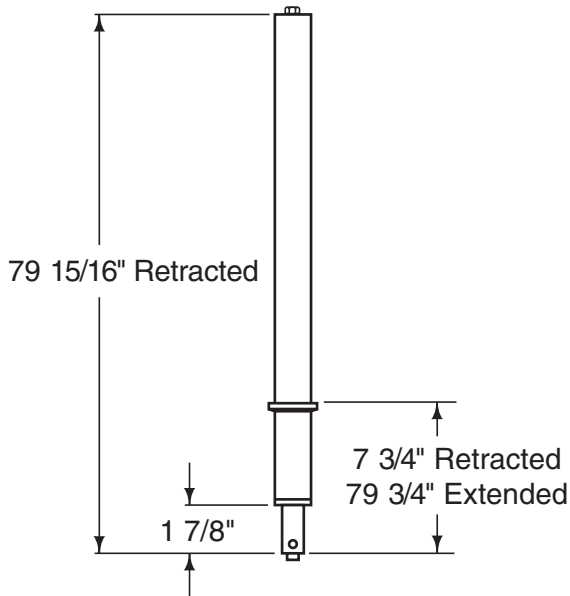

FJ7664/N310 Cylinder

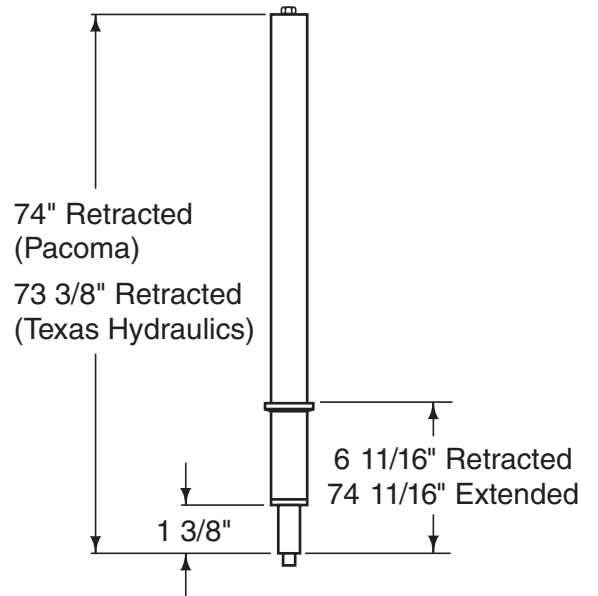

N380e Cylinder

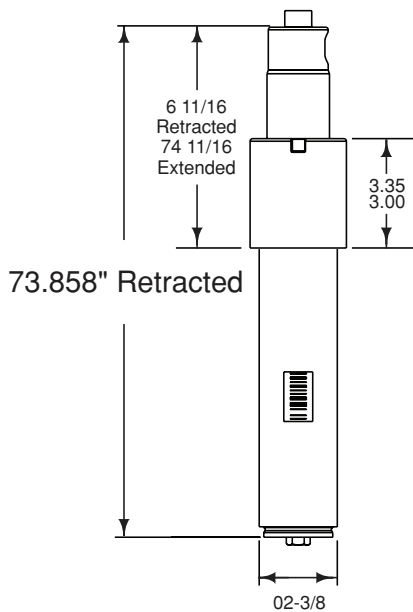

N380y Cylinder

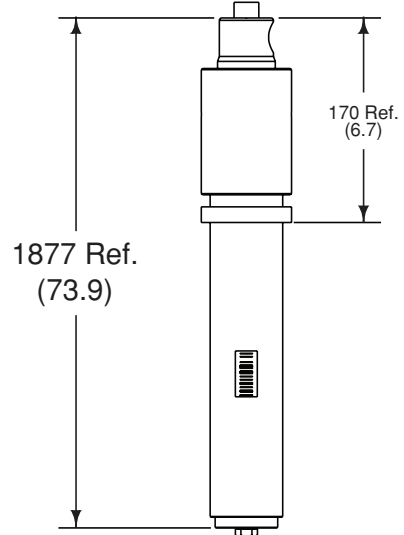



World Leader in Lift Systems

Revolution Cylinder Guide

Lift Model	Original Cylinder	Replacement Cylinder	Seal kit
Low Rise			
VMR6	FJ860	FJ860	FJ860-12TH
RMR6,	YG03-9100	YG03-9100	YG03-9180
MCY	MCY1-11	MCY1-11	N/A
MCY-S, RXLDT	YG09-9100	YG09-9100	YG09-9180
RLR6A, RLR6F, RLR6P,	FJ2248	FJ2248	FJ2248-12TH
2-Post			
RTP9	YG07-9100G1	YG07-9100G1	YG07-9180
RTP10	992317	992317	YG32-9180
4-Post			
RFP7P, RFP7N	S130093 (94" Stroke) S130095 (77" Stroke)	S130093 S130095	S130093-12
RFP9	YG36-9100G2	YG36-9100G2	YG36-9180
RFP14	YG18-9100G2	YG18-9100G2	YG18-9180



World Leader in Lift Systems

Rolling Jack Cylinder Guide

Cylinder Kit Identification Table

Rolling Jack

Bridge Model	Capacity	Original Cylinder	Replacement Cylinder	Seal kit
FC5124	3,000	FC570-2	FC570-2	FC570-2-12TH FC5409
FC5269	3,500	FC5185-20	FC5185-20	FC5410
FC5279	3,500	FC5185-20	FC5185-20	FC5410
FC5655	3,500	FC5642	FC5642	FC5642-12TH
FC5655-50	3,500	FC5642	FC5642	FC5642-12TH
FC5277	4,500	FC5185-20	FC5185-20	FC5410
FC5656	4,500	FC5642	FC5642	FC5642-12TH
FC5656-50	4,500	FC5642	FC5642	FC5642-12TH
RJ4500	4,500	FC5642	FC5642	FC5642-12TH
RJ4500Z	4,500	SB700027	SB700027	SB100032
SJ4500	4,500	N/A	N/A	SJ100001
FC5278	6,000	FC5185-20	FC5185-20	FC5410
FC5657	6,000	FC5642	FC5642	FC5642-12TH
FC5657-50	6,000	FC5642	FC5642	FC5642-12TH
RJ6000	6,000	FC5642	FC5642	FC5642-12TH
RJ6000Z	6,000	SB700027	SB700027	SB100032
SJ6000	6,000	N/A	N/A	SJ100002
RJ7000	7,000	SB700027	SB700027	SB100032
RJ7000Z	7,000	SB700027	SB700027	SB100032
FC5818	9,000	FC5818-18	FC5818-18	FC5818-18-12TH
RJ9000	9,000	FC5818-18	FC5818-18	FC5818-18-12TH
FC5341	15,000	FC5341-1	NLA	10649
FC5710	15,000	FC5711-1	FC5711-1	FC5711-1-12TH
RJ25	25,000	AB300006	AB300006	AP01514
RJ50	50,000	AB300007	AB300007	AP01515

FC5818-18 Cylinder

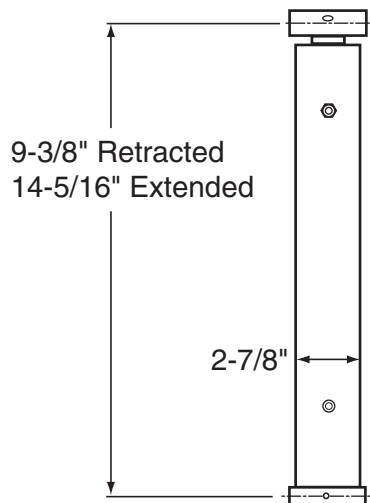

FC5642 Cylinder

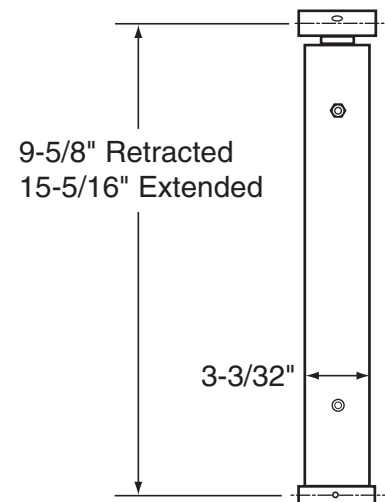

FC570-2 Cylinder

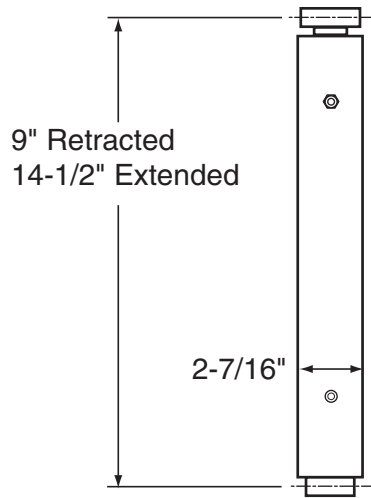

FC5711-1 Cylinder

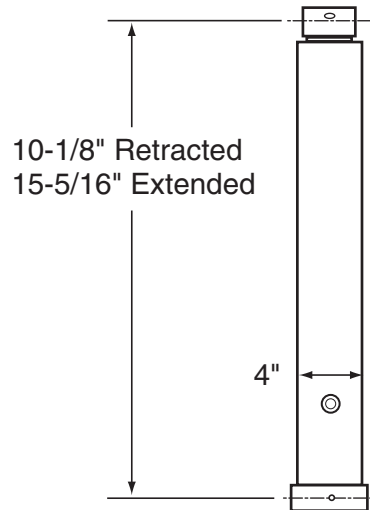

FC5185-20 Cylinder

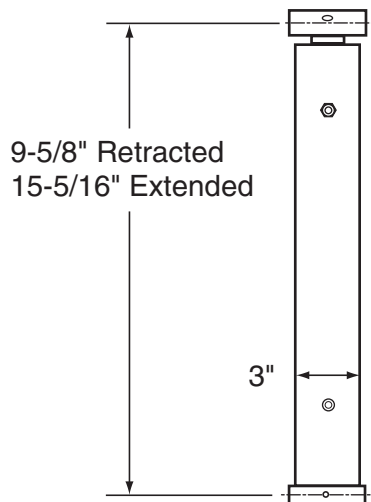

FC5341-1 Cylinder

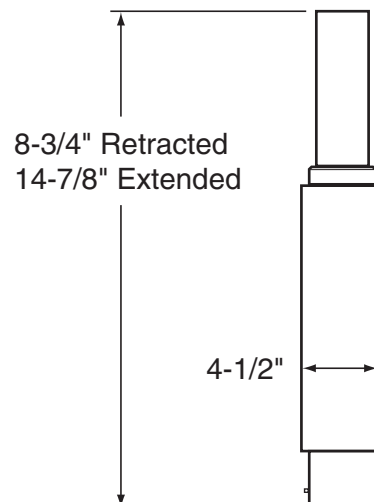



World Leader in Lift Systems

Accessories

Lift Model	Original Cylinder	Replacement Cylinder	Seal kit
Portable Productivity Jacks			
GUWSFF5, GUWSFF5-1			101151
GUWSFF5-100			112206
GUWSFF20			101152
Floor Running Pit Lift			
GHUSSFFT20-14			3720999
Suspended Pit Lift			
GHUSLP20			3720999
Volkswagen Lift Table			
VAS6131A	S2685-ZY1	S2685-ZY1	N/A



World Leader in Lift Systems

In-Ground Cylinder Guide

PB 10-4-8

Model	Plunder Diameter	Jack Serial #	Gasket Part #		Packing Gland #		Packing / Seal #	
			Original	Replacement	Original	Replacement	Original	Replacement
85, 86, 87, 88, 88B, 7, 7A	10 1/2	8000 Thru 8810 H011 Thru H4276	JK31	NLA	NLA	NLA	JK218	NLA
K8, K9, K10	9 1/2	K0001 Thru K2736	JH31	NLA	NLA	NLA	JK218	NLA
FH10G, RH10G, RH20G, 610G, 620G	10 5/8	G1139 Thru G1294 01 Thru 1138	Non Required	Non Required	NLA	NLA	JK218	NLA
805	8 1/2	B1 Thru B2690	JG31	NLA	NLA	NLA	JK219	NLA
905, 912, 915	9 1/2	B1 Thru B2690	JH31	NLA	NLA	NLA	JK219	NLA
1005, 1012, 1015	10 5/8	B1 Thru B2690	JK31	NLA	NLA	NLA	JK219	NLA
508	8 1/2	C100 Thru C4241 M1 Thru M2468	JG31	NLA	NLA	NLA	JK220	JK220KIT
419, 509, 619, 916, 1209, 1509	9 1/2	C100 Thru C4241 M1 Thru M2468	JH31	NLA	JH62	NLA	JK220	JK220KIT
420, 510, 620, 1016, 1210, 1510	10 5/8	C100 Thru C4241 M1 Thru M2468	JK31	NLA	JK62	NLA	JK220	JK220KIT
FA9, FH9, RA9, RA19, RH9, RH19, FU9, FU19, RU19, FC9	9 1/2	Ending in T1 Thru T9526	JH31	NLA	JH62	NLA	JK220	JK220KIT
FA10, FA20, FH10, FH20, FC10, RA10, RA20, RH10, RH10, RH20, T110, T210, T1012 (Front jack only)	10 5/8	Ending in T1 Thru T9526	JK31	NLA	JK62	NLA	JK220	JK220KIT
10FA, 10FH, 20RH, 20RA, T110, T210, T1012 (Front jack only)	10 5/8	Ending in V3 Thru V2880	JK32	NLA	JK610	NLA	JK220	JK220KIT
T112, T212, T1012 (Rear only)	12 5/8	Preceded by T or V	JL31	NLA	NLA	NLA	JL214	NLA

T112, T212, T212DS, T212LS, T1012, AT1012, AT1012DSE (Rear only)	12 5/8	Preceded by W or ending in W5, W6, W7	Non Required	Non Required	J167	J117	JL215	NLA
	12 5/8	Ending in W8, JL123, JL124	Non Required	Non Required	JL69	J117	JL215	NLA
	12 5/8	Ending in JL128 Thru JL133	Non Required	Non Required	JL610	J117	JL217	J117
	12 5/8	Ending in JL134 and above (except JL153)	Non Required	Non Required	JL612	JL612	JL220	JL220KIT
10AF & HF, 20AR & HR, 31AR & HR, 35AR & HR, T110A & H, 210A & H, T210DS, T210LS, T1010, FP10A & H, FP11A & H, FP45A, & H, FP12A & H, FP46A & H, FP36, VW5A & H, VF5A & H, DY10A & H, DRT10A & H, WABU10A & H, PF10A & H, PFV10A & H, AT70H & E, AT703E, AT704E, AT10210E, AT10210DSE, Rear jack only of AC60H & E, 810ML, 810MLS, 811ML, 710MLS, Front jack only of AT1012E, AT1012DSE	10 5/8	Preceded by W or ending in W5, W6, W7	Non Required	Non Required	JK69	NLA	JK221	NLA

		Ending in W8, JK123, JK124	Non Required	Non Required	JK69	NLA	JK221	NLA
		Ending in JK135 Thru JK157	Non Required	Non Required	JK69	J134	JK223	J134
		Ending in JK158 Thru JK1112	Non Required	Non Required	JK69	J134	JK225	J134
		Ending in JK1113 Thru JK1269	Non Required	Non Required	JK69	JK622	JK227	JK227KIT
FP46A & H, 70C,P & Q, 10210C,P & Q, R70C,P & Q, R10210C,P & Q, 703C, P & Q, R703C,P & Q, RU70C,P & Q, RU10210C,P & Q, RU703C,P & Q, 70HC, 60HC, 52HC	10 5/8	Ending in JK1303, JK1400 and above	JK238	JK238	Non Required	Non Required	JK238	JK238KIT
28ML & MLS, SE8, 29ML & MLS, 811ML, 78SF & ML	8 1/2	Ending in JG118 Thru JG127	Non Required	Non Required	JG67	J136	JK223	J136
FP8, VW4A & H, FP6, FP28A & H, FP7A & 5A, AP50H & E, AC60H & E Front jack only	8 1/2	Ending in JG128 Thru JG148	Non Required	Non Required	JG68	J139KIT	JG218	J139KIT
29ML, FP28H, DT028H, P20H, DTRP28H, WABU28H, WRP90,	8 1/2	Ending in JG149 Thru JG187 & JG190	Non Required	Non Required	JG620	JG620	JG220	JG220KIT
DT028H, WABU28H, PT20H, DTRP28H, RBU68H, AP50H & E, AC60H & E, 52HC, 52C, 52P, 710MLS (Front Jack)	8 1/2	Ending in JG188, JG189, JG191 and above	JG37 O-Ring	JG37 O-Ring	Non Required	Non Required	JG227	JG227KIT

94, 948, 96	8 1/2	90001 - 9999 1001-1999 X001-X999 A001-A773	JG31	NLA	NLA	NLA	JG216	NLA
27SL, 27ML, 78SF, 78ML	7 1/2	Ending in Y1 Thru Y5	Non Re- quired	Non Re- quired	NLA	NLA	JG216	NLA
FP27	7 1/2	Ending in JF15	Non Re- quired	Non Re- quired	JF64	NLA	JF214	NLA
FP28H, DT028H, PT20H, 710MLS (Front jack only)	7 1/2	Ending in JF19 Thru JF122	JF34 O-Ring	JF34 O-Ring	JF611	JF611	JF218	JF218
R12, FM12, FMRT12	12 5/8	JL1400 Thru JL1402	NLA	NLA	NLA	NLA	JL230	JL230KIT
MOD30	Multi-Stage	JT11	Non Re- quired	Non Re- quired	Non Re- quired	J156	J156-1 Lower J156-2 Lower	J157 (Com- plete) J157-1 Up- per J157-2 Lower
MOD30	Multi-Stage	JT14	Non Re- quired	Non Re- quired	Non Re- quired	J154	J154	J154

J134 is a seal and gland assembly consisting of JK227 seal, JK622 gland, JX207 bleeder and new hard wear.
This kit can be used to upgrade the JK225 and JK223 seals to the JK227 seal. This is required for a replacement of these older seals.
J136 seal and gland assembly consists of JG220 seal, JG620 gland, JX207 bleeder and hardware
J139 seal and gland assembly consists of JG220 seal, JG620 gland, JG36 spacer ring, JX207 bleeder and hardware
J117 seal and gland assembly consists of JF220 seal, JF612 gland, JX207 bleeder and hardware
J150 seal and gland assembly consists of JF218 seal, JF611 gland, JF34 o-ring, JX207 bleeder and hardware
J156 seal and gland assembly for a JT11 jack, consisting of a J156-1 upper seal and gland assy, J156-2 lower seal and gland assy.
J148 seal and gland assembly for High Pressure 10 5/8 Or Wash Bay

Bearing and Gland Replacement Kits

JG118 thru JG187 and JG190 use the JG629 bearing and gland replacement kit. It is required to use a JG230 mandrel for installation.
The mandrel is reusable
JK1113 thru JK1299 and use the JK629 bearing and gland replacement kit. It is required to use a Jk244 mandrel for installation.
The mandrel is reusable

TOOLS

JK244 10 5/8" mandrel
JG230 8 1/2" mandrel
PR810134 12 1/2" mandrel
IR06200010BK MOD30 JT14 clamp ring tool kit jack
PR080191BK MOD30 JT11 Spanner wrench



World Leader in Lift Systems

HD Surface

Lift Model	Original Cylinder	Replacement Cylinder	Seal kit
Movable Column			
HP413	HP13-48	HP13-48	HP13-124
MACH4	M130001	M130001	M130033
Parallelogram			
Classic			
34/27F (6" Cyl.Flush)	AP00741	AP00741	AP00704
45/35S (6" Cyl.Surface)	AP00642	AP00642	AP00704
50/25F (7" Cyl.Flush)	AP00742	AP00742	AP00696
50/25S (7" Cyl.Surface)	AP00643	AP00643	AP00696
50/26S (7" Cyl.Surface)	AP00643	AP00643	AP00696
50/32S (6" Cyl.Surface)	AP00642	AP00642	AP00704
50/48S (7" Cyl.Surface)	AP00950	AP00950	AP00696
Gen 2			
1995- 2001(April)			
5 1/2" Cyl. Surface	610-307-00	591-01-1580	AP01808
6" Cyl. Surface/Flush	AP01397	AP01397	AP00704
7" Cyl. Surface	AP01398	AP01398	AP00696
7" Cyl. Flush	705-305-00	591-01-1630	AP00696
Gen 3			
2001(May)-2008			
5 1/2" Cyl. Surface	AP02668	AP02668	AP01808
6" Cyl. Surface	AP02626	2005-13-312-00	AP02746
6" Cyl. Flush	AP02650	2005-14-312-00	AP02746
7" Cyl. Surface in Res.	AP01398	AP01398	AP00696
7" Cyl. Surface	AP02598	2005-17-312-00	AP00696
7" Cyl. Flush	AP02682	2005-18-312-00	AP00696
Gen 4			
2009-Current			
5 1/2" Cyl. Surface	AP02668	AP02668	AP01808
6" Cyl. Surface	AP02626	2005-13-312-00	AP02746
6" Cyl. Flush	AP02650	2005-14-312-00	AP02746
7" Cyl. Surface	AP02598	2005-17-312-00	AP00696
7" Cyl. Flush	AP02682	2005-18-312-00	AP00696

Rotary World Headquarters

2700 Lanier Drive
Madison, IN 47250, USA
www.rotarylif.com

North America Contact Information

Tech. Support: p 800.445.5438
f 800.578.5438
e userlink@rotarylif.com
Sales: p 800.640.5438
f 800.578.5438
e userlink@rotarylif.com

World Wide Contact Information

World Headquarters/USA: 1.812.273.1622
Canada: 1.905.812.9920
European Headquarters/Germany: +49.771.9233.0
United Kingdom: +44.178.747.7711
Australasia: +60.3.7660.0285
Latin America / Caribbean: +54.3488.431.608
Middle East / Northern Africa: +49.771.9233.0

© Rotary®, Printed in U.S.A., All Rights Reserved. Unless otherwise indicated, ROTARY, DOVER and all other trademarks are property of Dover Corporation and its affiliates.



A **DOVER** COMPANY

