

*World Leader in Lift Systems*

***2-Post  
Cylinder  
Guide***

## ***TABLE OF CONTENTS***

Cylinder Trouble Shooting on “SP” Series Lifts .....	3
Assembly Instructions For Kit #FJ7375 .....	5
FJ592 Cylinder Bleeder Replacement Kit .....	6
Exploded View of Cylinder (Sample) .....	7
2-Post Cylinder Manufacturers Guide .....	7
2-Post Cylinder Identification Table .....	8



## ***Cylinder Trouble Shooting On "SP" Series Lifts***

- 1) Customer complaint: Fluid leaking and/or accumulating around base of lift.
- 2) Possible causes:
  - A) Oil on floor due to causes other than leaks at lift.
  - B) Fitting at base of cylinder leaking.
  - C) Manual bleeder leaking.
  - D) Cylinder leaking from seal.
  - E) Leaks oil from breather.
  - F) Hose leaking or weeping.

### ***How to Check Hydraulic System***

- 1) Clean all oil points.
- 2) Raise lift all the way up and hold it under pressure for 10 seconds.
- 3) Relieve pressure at lowering valve.
- 4) Check all possible leak points.
- 5) If leaks are found, determine the extent of repair needed.

### ***If The Cylinder Is leaking From Seal***

**\*\*\*Before removing cylinder make sure you have the correct seal kit.\*\*\***

### **Double "S" Formed Column Lifts.**

#### ***Cylinder Removal Procedure***

- 1) Loosen the equalizer cable on the opposite carriage.
- 2) Raise the lift to the top and rest the carriage on the top latch position.
- 3) Check to make sure the carriage is secure on latches.
- 4) Make sure the pressure has been relieved from the system.
- 5) Follow the proper LOCKOUT/TAGOUT procedures for disconnecting power to lift.
- 6) Remove the lower sheave cover at base of column.
- 7) With lowering valve depressed, manually pull cylinder down out of carriage.
- 8) Disconnect the swivel hose fitting at base of cylinder.
- 9) Cap hose ends and cylinder adapter to prevent fluid loss.
- 10) Carefully remove cylinder from column.

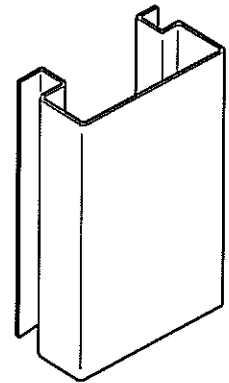

#### ***Cylinder Rebuilding***

**\*\*\*Kit has only enough parts for (1) cylinder.\*\*\***

- 1) Remove manual bleeder and extend plunger from casing.
- 2) Remove piston retaining ring or clip.
- 3) Remove plunger from casing.
- 4) Clean inside of casing, making sure all debris is removed with mineral spirits.
- 5) Inspect seal for damage.
- 6) Replace seal and all other components (wiper, wear ring, etc.).
- 7) Coat seal with oil or white grease.
- 8) Reinstall plunger, retaining ring, and manual bleeder being careful not to scratch or dent plunger surface.

#### ***Cylinder Replacement***

- 1) Reinstall cylinder and reconnect hose fitting.
- 2) Reconnect power source.
- 3) Install lower sheave cover.
- 4) Raise cylinder in column through the carriage lifting plate and cylinder centering bar.
- 5) Lower both carriages.
- 6) Adjust equalizer cables.
- 7) Carefully raise carriages about two feet. Bleed air from both cylinders.
- 8) Fully lower lift.
- 9) Check and add fluid as necessary.
- 10) Raise lift to full rise and check for leaks.
- 11) Tag lift back in service.

## SP84, SPOA84, SP94, Series Lifts

### ***Cylinder Removal Procedure***

- 1) Raise the lift about 2'-0". Open manual bleeder in top of both cylinders to bleed off any air pockets. Close bleeder when fluid appears. Lower lift.
- 2) Remove arm pins and swing arms.
- 3) Disconnect both cables at upper tie-off.
- 4) Manually lift carriage to its top locking position. Let carriage rest on latch. Place a suitable support under carriage.
- 5) Remove the upper cable sheave bracket. (Also column extensions on SPO models.)
- 6) Disconnect hydraulic line and unscrew adapter at the cylinder base.
- 7) Remove 1/4" x 4-1/2" HHCS at base of cylinder.
- 8) Manually lift carriage until upper rollers or slider blocks start to protrude above column.
- 9) Angle cylinder out of column through front opening and lower carriage back in top latch position.

### ***Cylinder Rebuilding***

- 1) Using a spanner wrench or other suitable tool, turn cylinder casing clockwise, until straight end of retainer ring is located in the mill slot on the cylinder casing.
- 2) Insert screwdriver under beveled edge of retainer ring.
- 3) Turn casing head counterclockwise until retainer ring is removed.  
*Note: If cylinder is laying horizontally, place oil pan under cylinder head area before casing head is removed.*
- 4) Remove casing head.
- 5) Open manual bleeder vent at top of cylinder and remove entire plunger from cylinder casing and inspect for nicks, scratches, etc.
- 6) Install new seal kit.
- 7) Apply a generous coating of Dexron III ATF on new seal kit components.
- 8) Insert plunger in cylinder, being careful not to scratch finish.
- 9) Insert cylinder casing head and line up retainer ring slot with mill slot in cylinder casing.
- 10) Insert bent end of retainer ring into slot.
- 11) Turn casing head clockwise until retainer ring is completely inside casing.
- 12) Close the manual bleeder valve.

### ***Cylinder Replacement***

- 1) Install hex adapter on new cylinder.
- 2) Again, manually lift the carriage and insert cylinder in the column.
- 3) Lower carriage to top locking latch position.
- 4) Secure cylinder in column and replace 1/4" bolt.
- 5) Reinstall upper sheave bracket.
- 6) Reconnect hydraulic line.
- 7) Lift carriage off locking latch and position latch arm to disengage the latch.
- 8) Lower carriage to floor.
- 9) Reconnect cable to upper cable tie-off. BE SURE cables are roped through sheave rollers.
- 10) Raise lift about 2'-0" and open manual bleeder in top of cylinder. Close when fluid appears.
- 11) Remove filler breather cap from power unit and refill reservoir with Dexron III, ATF.
- 12) Raise lift to full travel and adjust tension on cables. Grasp cables between thumb and forefinger. With about 15lbs. tension, you should just pull the cables together.
- 13) Tighten cable jam nut on upper cable tie-off stud.
- 14) Lower lift and reassemble arms and pins.
- 15) Raise lift to full travel and check pipe joints for leaks.
- 16) The lift should now be ready for use.



# Assembly Instructions For Kit #FJ7375 (To replace FJ783 Cylinder)

1. Lubricate "O" Rings on Reducer and expander fittings and install reducer into supplied cylinder FJ7211. (Fig. 2)
2. Install expander into reducer. (Fig. 2)
3. Clean supplied adapter FJ7353-2. Back nut away from groove in fitting. Push washer back to end of groove.
4. Push "O" ring back to washer. Lubricate "O" ring.
5. Screw fitting into expander until the washer contacts fitting. (Fig. 2)
6. Turn fitting counter clockwise less than one turn to lineup 1/4" pipe port (Fig 1). Hold fitting and tighten nut to 35-40 foot-pounds torque.
7. There is a mix of restricted and nonrestricted cylinders serviced by kit #FJ7375. Lift performance can be affected when nonrestricted and restricted cylinders are utilized on opposite sides of a lift. This kit contains adapters which have a restrictive feature built in to equalize cylinder rate of travel. Identification of cylinders are found as shown in figure 3. All FJ783 cylinders require restricted adapter FJ7757. All FJ7211 cylinders supplied by Texas Hydraulics with a date code prior to 168 Require a FJ7755 adapter. All FJ7211 cylinders supplied by Pacoma with a code prior to 3401529M96 require a FJ7755 adapter. Check the code on all cylinders and assemble appropriate adapter into the cylinder not being replaced to insure all cylinders are restricted.

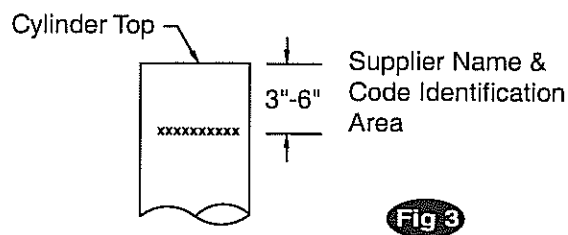
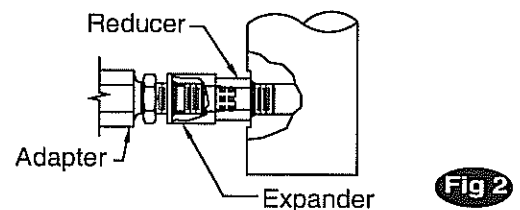
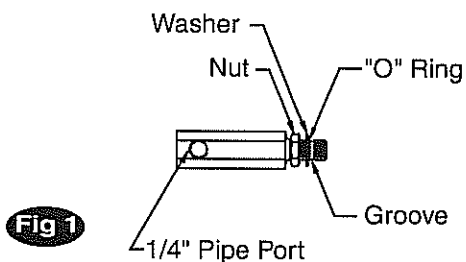

# FJ592 Cylinder Bleeder Replacement Kit Installation Instructions

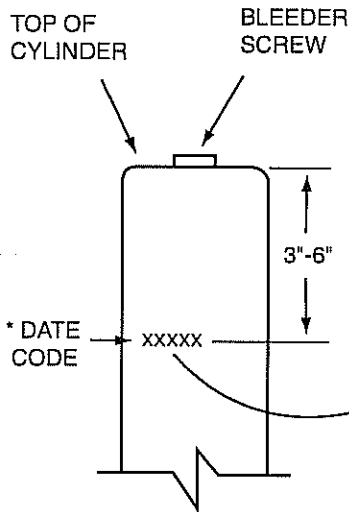

Replace using the correct bleeder screw for the model you have. Use the chart below to determine type of cylinder used. Date codes for identifying can be found using the illustration below.

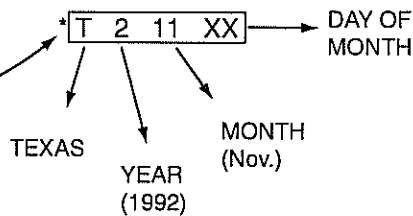

## Bleeder Screws For Texas Hydraulics Cylinders

Part No#. 32516 - Date code T211XX & after (Nov. 92)  
 Consists of: Part No# 32326 Screw & Part No# 14525 O-Ring Washer

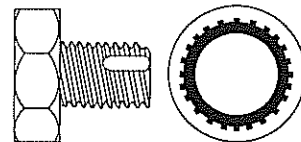

## Bleeder Screws For Pacoma Cylinders

Part No#. 3443881 MI - All cylinders used the same screw.

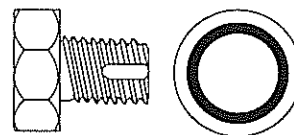

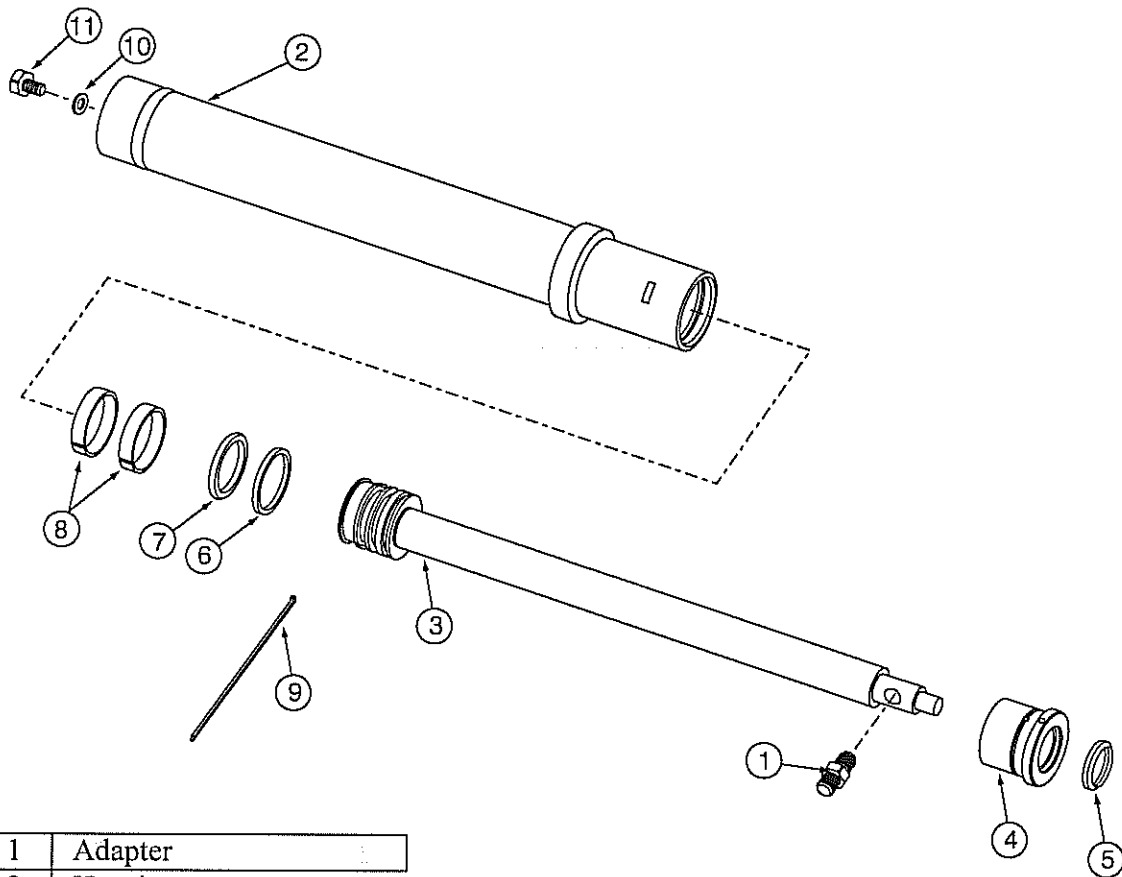

1	Adapter
2	Housing
3	Piston Rod
4	Bushing Guide
5	Felt Wiper
6	Felt Ring
7	Seal
8	Guide Ring
9	Retainer Wire
10	Seal
11	Bleeder Plug

## 2-Post Cylinder Manufacturers

CYLINDER	TEXAS HYDRAULICS	PACOMA	BEST METAL PRODUCTS
FJ7664	X	X	
FJ783	X	X	
FJ7604	X	X	
FJ76	X	X	
FJ7311	X	X	
FJ720	X		X
FJ7211	X	X	

## *Cylinder Kit Identification Table 2-Post Surface and Inground Lifts (SL Models)*

Lift Model	Orig. Cyl.	Cylinder	Seal Kit
SP70; SP74	FJ76	FJ76	FJ76-12
SP80 thru SP80-3 SP84 thru SP84-7	FJ720	FJ720	FJ720-12
SP80-4; SP80-5; SP84-8 thru SP84-11 SP84-16; SPO84; AR94; ARO94; SP94; SPO94; SP55; SPOA84; SPOA84NB(Narrow Bay); **SPOA84LC 4" Restricted Rise; **SPOA84LC 8" Restricted Rise; **SPOA84LC 4" (Narrow Bay) Restricted Rise; **SPOA84LC 8" (Narrow Bay) Restricted Rise;	FJ7211 FJ783	FJ7211 FJ7375	*FJ783-12 MF *FJ783-12 TH
SP88; SP98; SPO88; SPO98; SPOA88; DCOA7; SPOA98; SPO82; SPOA82; AR98; ARO98	FJ7311	FJ7311	*FJ783-12MF *FJ783-12TH
SP7; SP9; SPO7; SPO9; SPOA7; SPOA9; AR9; ARO9; TLO7	FJ7664	FJ7664	*FJ783-12MF *FJ783-12TH
SL28; SL9	FJ7664	FJ7664	*FJ783-12MF
SL19	FJ7604	FJ7604	FJ7604-12MF
SPO12; SPO15; SPO18	FJ7604	FJ7604	*FJ7604-12 MF
SPALC7; SPOA7LC	FJ7606	FJ7606	FJ7606-12 TH
SPO12-10	***N310	FJ7664	*FJ783-12 TH *FJ783-12 MF

\* Rotary Lift had different cylinder suppliers for these cylinders. To identify the correct Seal Kit, observe the marking in the casing approximately 6" from the bleeder screw. The word Pacoma indicates MF Seal Kits. The letters T.H., T.X., a four digit number, or no markings at all indicate TH Seal Kits.

\*\* Restricted Rise means the cylinder stroke can be checked by subtracting the overall retracted cylinder length from the overall extended cylinder length.

\*\*\* N310 is a FJ7664 cylinder with a flow control assembly.

**Note:**

- Look all the way around the casing for the markings.





**FJ720 Cylinder**

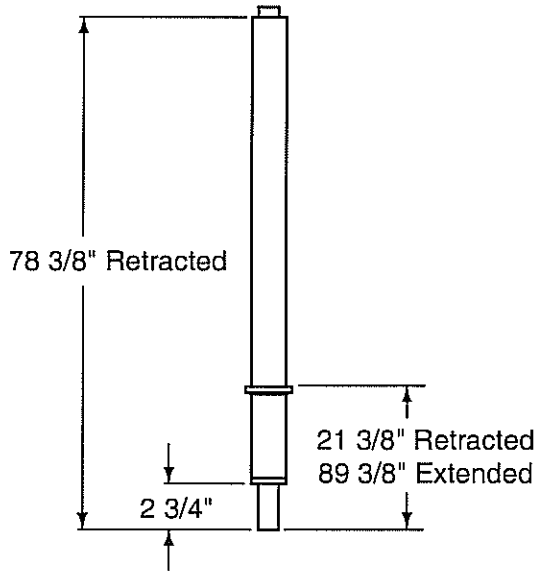

**FJ7375 Kit/FJ7211 Cylinder**

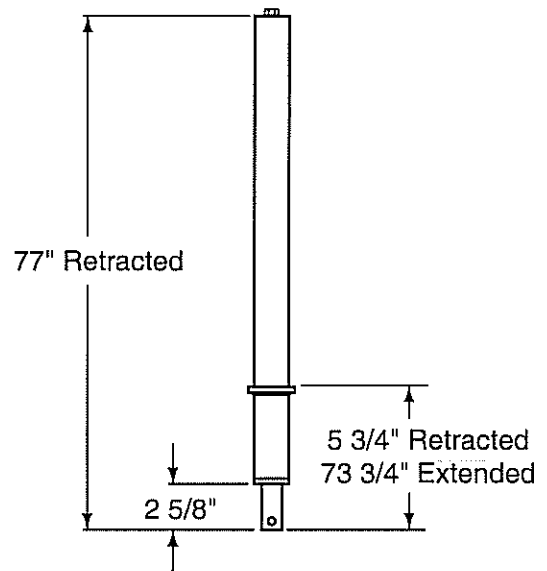

**FJ7311 Cylinder**

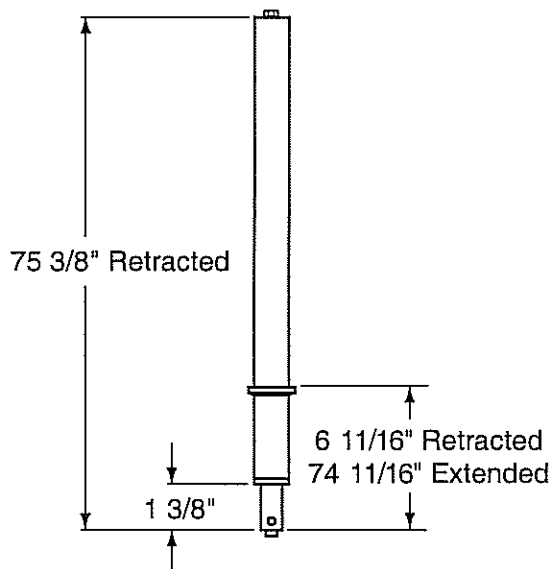

**FJ7604 Cylinder**

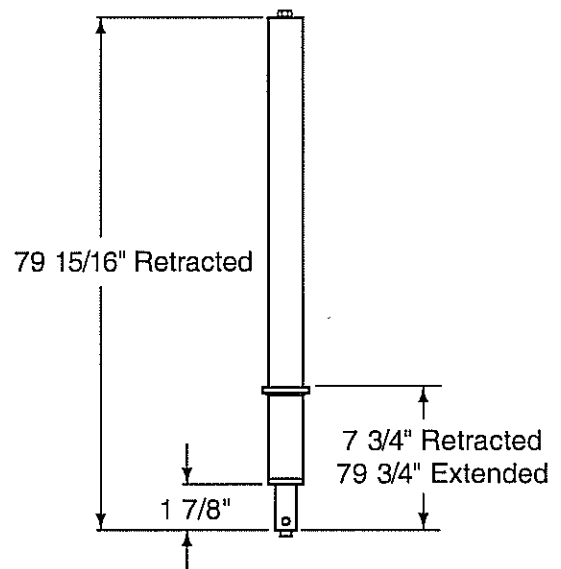

**FJ7606 Cylinder**

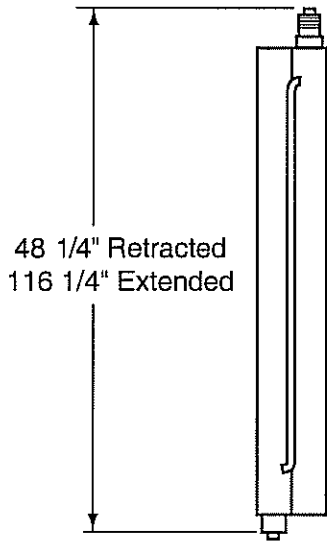

**FJ7664/N310 Cylinder**

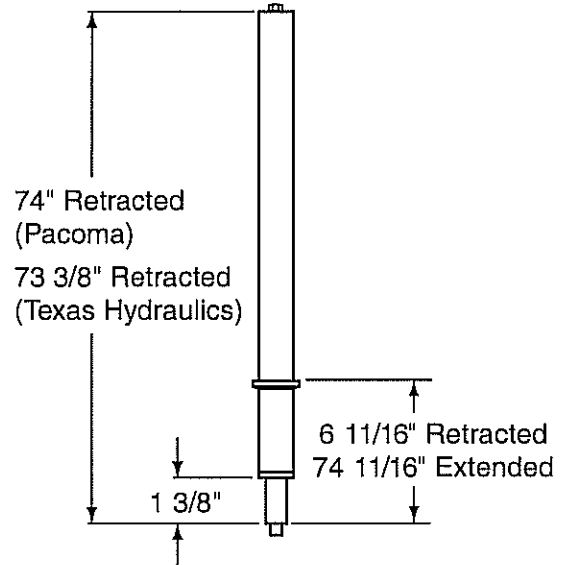

**FJ76 Cylinder**

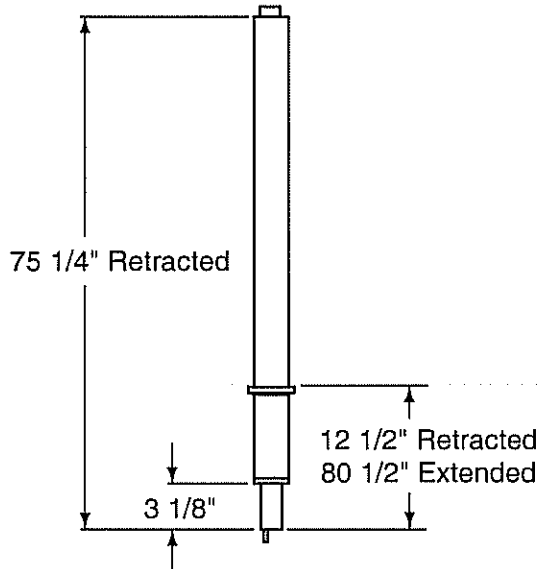

**FJ783 Cylinder**

