

CL Challenger Lifts

Installation, Operation & Maintenance Manual

MODEL RJ6

ROLLING JACK

(Model 40 Series 4-Post only)

6,000 lbs Capacity



200 Cabel Street, P.O. Box 3944 Louisville, Kentucky 40201-3944
Email: sales@challengerlifts.com Web site: www.challengerlifts.com

Office 800-648-5438 / 502-625-0700 Fax 502-587-1933

**IMPORTANT: READ THIS MANUAL COMPLETELY
BEFORE INSTALLING or OPERATING JACK**

⚠ CAUTION

- ◆ Before using this product, read and fully understand the operating instructions and all decals on the product. This is necessary to prevent injury to the operator and damage to the product.
- ◆ Roll jack forward before moving vehicle on or off lift.
- ◆ Do not attempt to use this jack for anything other than its intended purpose.
- ◆ If jack begins to tilt as the vehicle is raised, STOP! Lower jack and reposition the vehicle.
- ◆ Do not use this jack if it is visibly worn, distorted or damaged.
- ◆ Maximum air operating pressure not exceed 150 p.s.i.
- ◆ Always wear appropriate eye protection.

⚠ WARNING

- ◆ Maximum lift capacity of this jack is 6000lbs (2272 kg)
Exceeding this could result in severe personal injury or death.
- ◆ Lift vehicle at manufacturer's recommended pick-up points only.
Vehicle weight must be evenly distributed on each jack lift pad.
- ◆ Keep fingers and hands clear of all pinch points at all times.

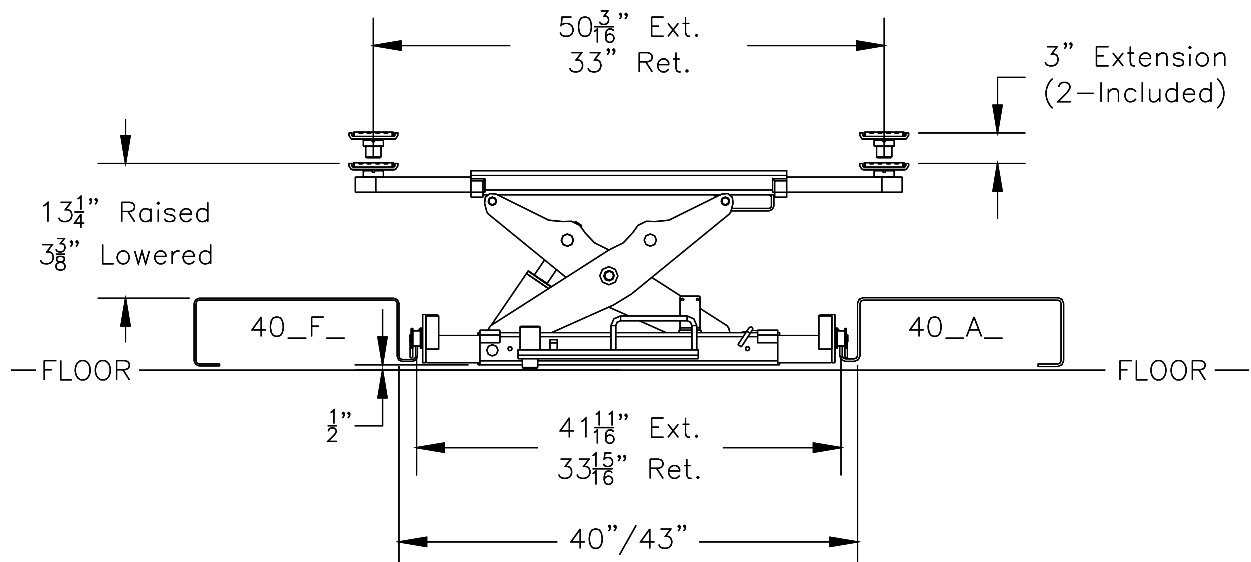

RJ6 Installation, Operation and Maintenance Manual

INSTALLATION

- 1) Replace Oil fill plug with the Breather Plug (provided) before use.
- 2) Install a ¼ NPT male quick disconnect coupling in air inlet of F.L.R. pre installed on jack. Match to shop fittings.
- 3) Place jack assembly on lift rack rails.

Operation

Note: Before lifting a vehicle, operate the jack through a couple of cycles to become familiar with the controls.

- 1) Roll jack forward before moving vehicle on lift rack. Be sure vehicle is centered on rack, apply parking brake and chock wheels.
- 2) Roll jack(s) to the vehicle manufacturer's recommended pick-up points. Extend lift pad arms to proper lift points. Use lift pad spacers if necessary.
- 3) Raise jack by pushing on foot pedal on pump.
- 4) Raise vehicle to desired height.
- 5) Lower jack onto lock.
- 6) To lower jack completely, raise off of lock and while holding lock release handle open lower jack. Push lift pad arms in, remove lift pad spacers (if used). Roll jack forward before moving vehicle off rack.

Adjusting the Release Mechanism

- 1) Loosen the "Adjusting Screw"
- 2) Verify that the "Adjusting Plate" is free.
- 3) Depress the "Air Inlet Stem" with the "Foot Pedal". The pump will now run and build pressure.
- 4) Release the "Foot Pedal". The pump will stop running, but hydraulic pressure will be held.
- 5) With the "Foot Pedal" resting on the "Air Inlet Stem" rotate the "Adjusting Plate" clockwise until a stop is felt.
Note: If the end of the slot in the "Adjusting Plate" is met before a stop is felt, the "Adjusting Plate" must be repositioned one step counterclockwise on the "Hex Stem", then repeat step #5.
- 6) Tighten the "Adjusting Screw". The release mechanism is now properly set.

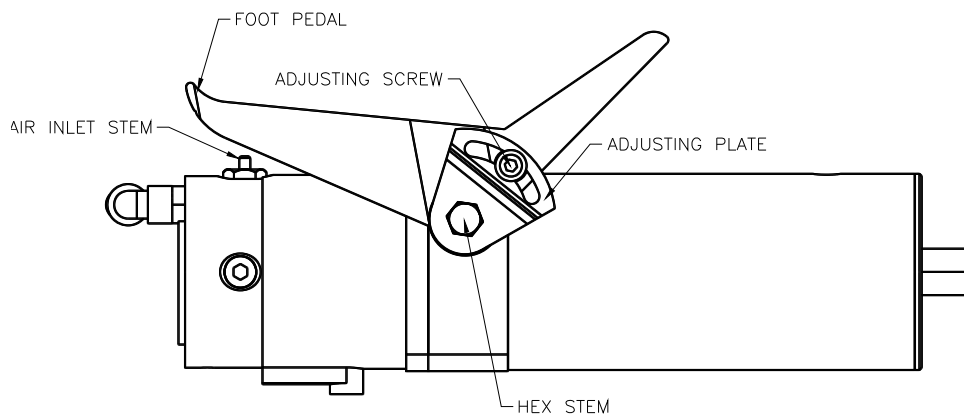

Maintenance

Daily: Inspect jack and it's components for damage or excessive wear. Replace parts as required. See parts list.

Inspect air/hydraulic system for leaks. Check in-line lubricator oil level.

Annually: Check hydraulic pump fluid level. When jack is completely lowered remove breather plug and check oil level. Oil should be at top of filler plug hole.

IMPORTANT!

Failure to keep lift free of corrosive agents and solvents will lead to reduced service life, which could result in property damage and/or personal injury. If any problems are encountered, contact your local service representative.

Parts Breakdown

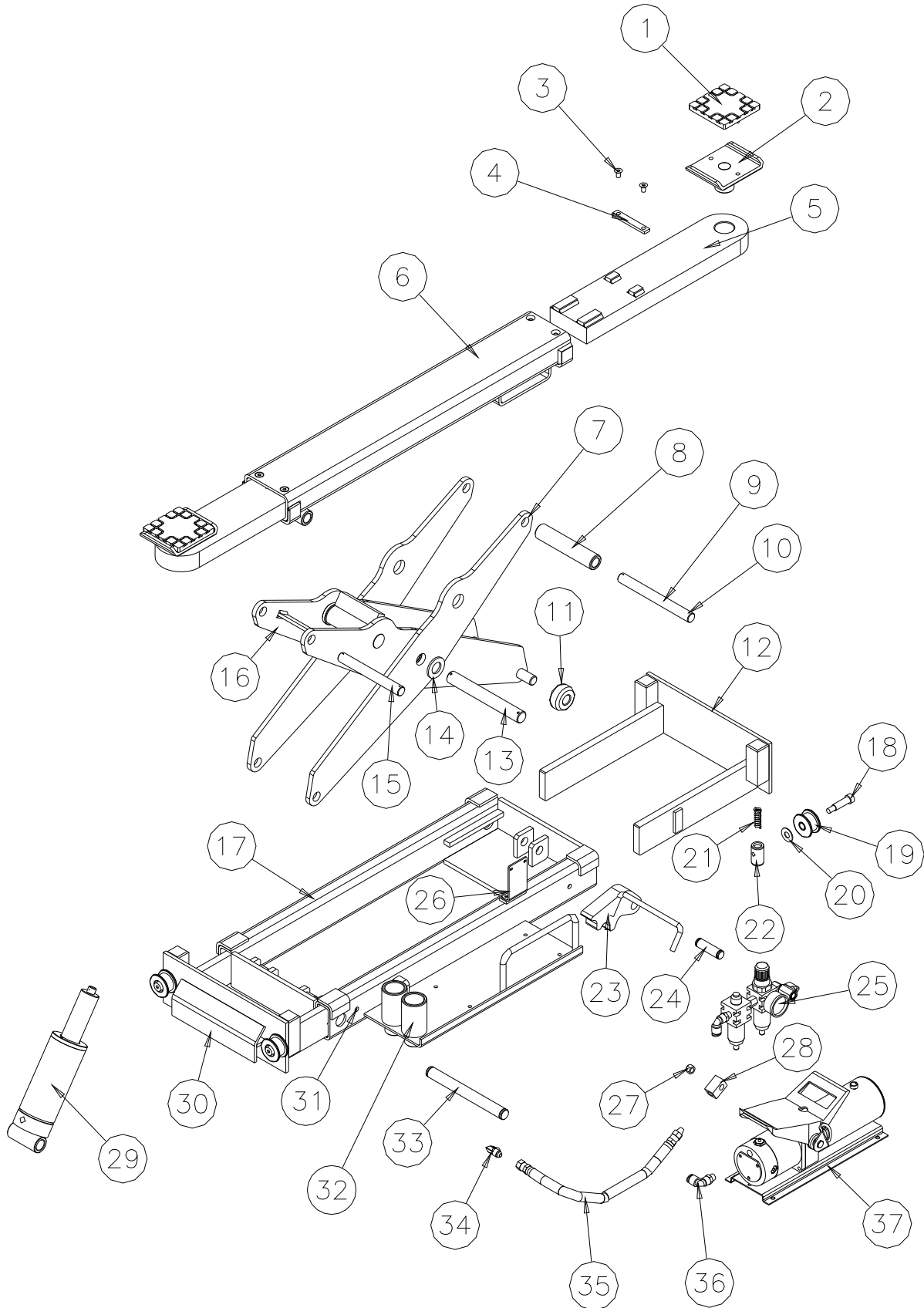

RJ6 Installation, Operation and Maintenance Manual

Item Number	Part Number	Qty/Jack	Description
1	B1104	2	Rubber Insert
1A	VS10-35-05	4	M6 Nylon Locknut
2	RJ6-04	2	Foot Pad
3	VS10-31-08	4	M8 x 12 Flat Head Screw
4	RJ6-19	2	Stop Bar
5	RJ6-02CH	2	Arm
6	RJ6-01CH	1	Sleeve
7	RJ6-07CH	2	Outer Scissor Plate
8	RJ6-06-04	1	Upper Pin Roller
9	RJ6-13	1	Upper Pin
10	VS10-20-10	6	5mm Roll Pin
10A	X10-099	4	20mm Washer
11	RJ6-18	2	Roller
12	RJ6-15CH	2	Side Member Weld
13	RJ6-08	1	Main Pin
14	RJ6-23	2	Spacer Washer
15	RJ6-12	1	Upper Pin, Fixed End
16	RJ6-06CH	1	Internal Scissor
17	RJ6-11CH	1	Jack Body
18	RJ6-27	4	Shoulder Bolt
19	RJ6-17	4	Wheel
20	RJ6-24	4	Nylon Washer
21	RJ6-26	4	Compression Spring
22	RJ6-25	4	Carrier
23	RJ6-16CH	1	Lock
24	RJ6-20CH	1	Lock Pin
24A	RJ6-35	2	18mm Snap Ring
25	GZZ	1	FLR Assembly, Including Gage and Fittings
26	RJ6-28	1	FLR Bracket
27	X10-096	1	M10 Nylon Locknut
28	QYB1-4-1	1	Hose Block
28A	RJ6-37	1	4mm x 50mm Cotter Pin
29	RJ6-09CH	1	Cylinder
30	RJ6-15-00CH	2	Side Member Assembly
31	X10-077	4	M10 x 25 HHCS
31A	RJ6-38	4	M10 Hex Nut
32	RJ6-05	2	3" Stack Pad
32A	RJ6-36	2	15mm Snap Ring
33	RJ6-14	1	Cylinder Pin
34	RJ6-22CH	1	Hydraulic Elbow
35	RJ6-21CH	1	Hydraulic Hose
36	RJ6-31	2	10mm Push Loc Elbow
37	QYB1-00	1	Air/Oil Pump

IMPORTANT!

Replace all worn or broken parts with **genuine Challenger Lifts, Inc. parts**. Contact your local Challenger Lifts parts distributor for pricing and availability. Call Challenger Lifts, Inc. at **(502) 625-0700** for the distributor in your area.