



Wind Things Up With Reelcraft

# HOSE REEL

## OPERATING INSTRUCTIONS & PARTS LIST

### MODELS

#### LOW PRESSURE

D8600 OLP  
D8640 OLP  
D8650 OLP  
D8670 OLP

D8800 OLP  
D8830 OLP  
D8840 OLP  
D8850 OLP

### SAFETY

- I. Do not use reels at higher pressures or temperatures than listed on the back of this bulletin.
- II. Remove all spring tension before beginning disassembly process.

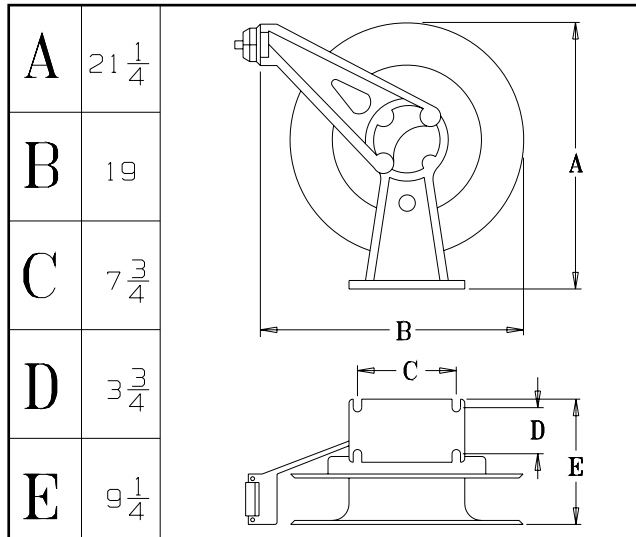

Four 1/2" Dia. Mounting Slots

## INSTRUCTIONS

**INSTALLATION:** A flexible hose connection must be used between the hose reel inlet and the source of supply to prevent possible misalignment and binding.

**MOUNTINGS:** The hose reel is equipped with a universal mounting bracket so that it can be mounted on the floor, wall or ceiling; whichever place is convenient. The hose guide arm can be moved to the position desired by removing the screws fastening the guide bracket to the reel base. Shift the guide arm bracket so the hose comes off the reel at the desired position and replace the screws.

**LUBRICATION:** Hose reel spring and bearings are factory lubricated and require no further lubrication.

**REPLACING HOSE:**

1. Wind spool flange clockwise -- facing swivel -- until spring is tight.
2. Back off two turns and latch.
3. Insert hose through roller guide.
4. Connect hose fitting to female outlet ell.

**ADJUSTMENTS:** To adjust spring tension, add or remove wraps of hose from the spool, one wrap at a time until desired tension is obtained.

**REPAIRS:** Extensive repairs should be performed only by an authorized serviceman or factory to avoid damage which may void your warranty. Remove all spring tension before beginning disassembly process.

# REELCRAFT

Wind Things Up With Reelcraft

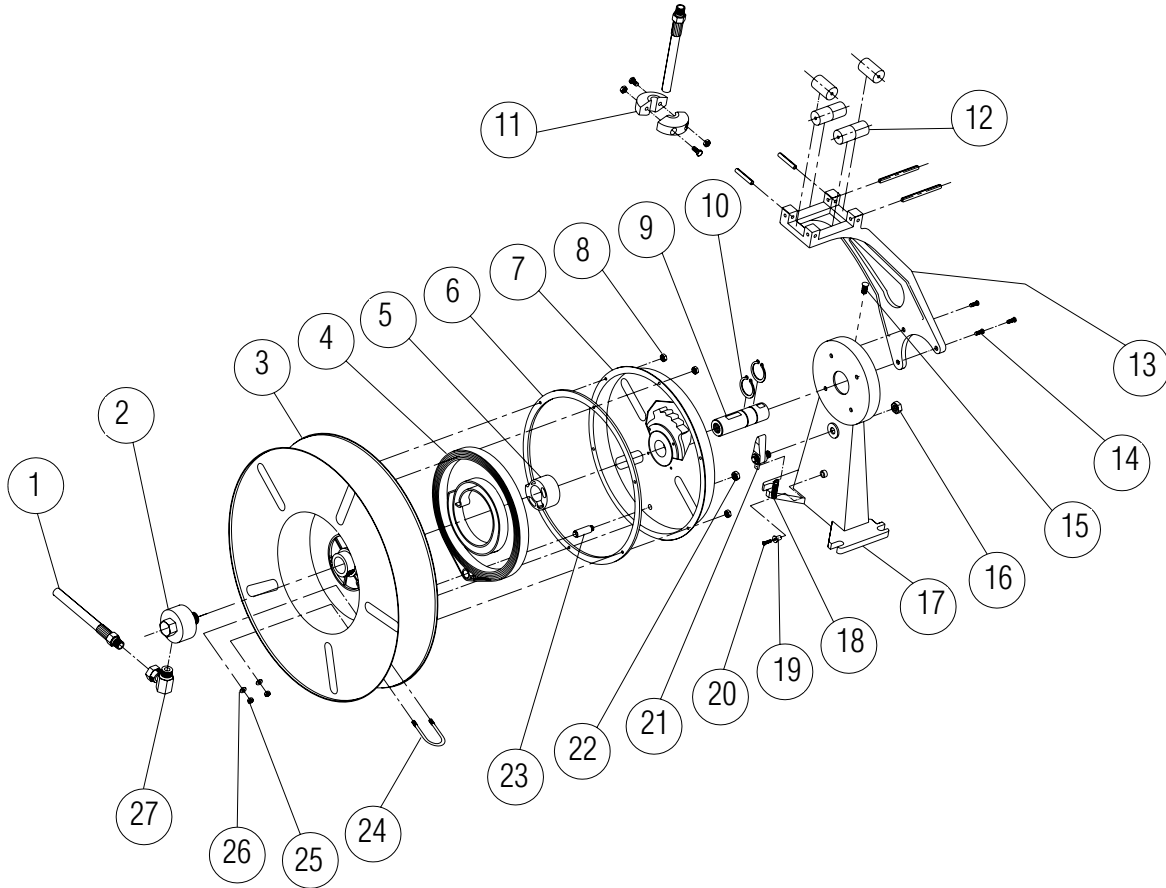

ITEM #	PART NO.	NO. REQ.	DESCRIPTION	ITEM #	PART NO.	NO. REQ.	DESCRIPTION	ITEM #	PART NO.	NO. REQ.	DESCRIPTION
2	600923	1	Swivel Ass'y	12	S260045	1	Guide Roller & Pin Kit	20	300042	1	10-24 x 1" Screw
3	260011	1	Sheave Ass'y	13	260007	1	Guide Arm Ass'y	21	S600083	1	Latch Pawl Ass'y
5	S600516	1	Spring Arbor Ass'y	14	507286	3	5/16-18 x 1 1/4" Screw	22	S76-106	1	3/8-24 Hex Jam Nut
6	S260069	1	Gasket	15	S35-86	1	1/2-13 Set Screw	23	S260031	1	Spring Case Stud
7	S260074	1	Spring Case Ass'y	16	S280-8	1	1/2-20 Hex Nut	25	300070	4	1/4-20 Nyloc Nut
8	300011	6	10-32 Hex Nut	17	260073	1	Base Casting	26	300039	4	Washer
9	260442	1	Main Shaft	18	S260067	1	Latch Spring	27	S257-26	1	Swivel Union
10	300007	3	1 1/4" Snap Ring	19	S400012	1	Latch Bushing				

ITEM #	DESCRIPTION	NO. REQ.	MODEL D8600 OLP	MODEL D8640 OLP	MODEL D8650 OLP	MODEL D8670 OLP	MODEL D8800 OLP	MODEL D8830 OLP	MODEL D8840 OLP	MODEL D8850 OLP
1	Hose Ass'y	1	None	601014-40	601017-50	601017-70	None	601021-30	601019-40	601021-50
4	Drive Spring Ass'y	1	S260028	S260028-1	S260028-1	S260028	S260037	S260037	S260037	S260037
11	Hose Bumper	1	None	1-HR1004-3	1-HR1004-3	1-HR1004-3	None	2-HR1004-3	2-HR1004-3	2-HR1004-3
24	U-Bolt	2	2-117440	2-117440	2-117440	2-117440	3-117440	3-117440	3-117440	3-117440

Hose I.D. & Length	None	3/8" x 40'	3/8" x 50'	3/8" x 70'	None	1/2" x 30'	1/2" x 40'	1/2" x 50'
Reel Inlet Connection	1/2" F.P.T.	1/2" F.P.T.	1/2" F.P.T.	1/2" F.P.T.	1/2" F.P.T.	1/2" F.P.T.	1/2" F.P.T.	1/2" F.P.T.
Maximum Operating Pressure	500 P.S.I.	300 P.S.I.	300 P.S.I.	300 P.S.I.	500 P.S.I.	300 P.S.I.	300 P.S.I.	300 P.S.I.
Maximum Operating Temperature	210°F	150°F	150°F	150°F	210°F	150°F	150°F	150°F