

CL Challenger Lifts

Installation, Operation & Maintenance Manual

Two Post Surface Mounted Lift

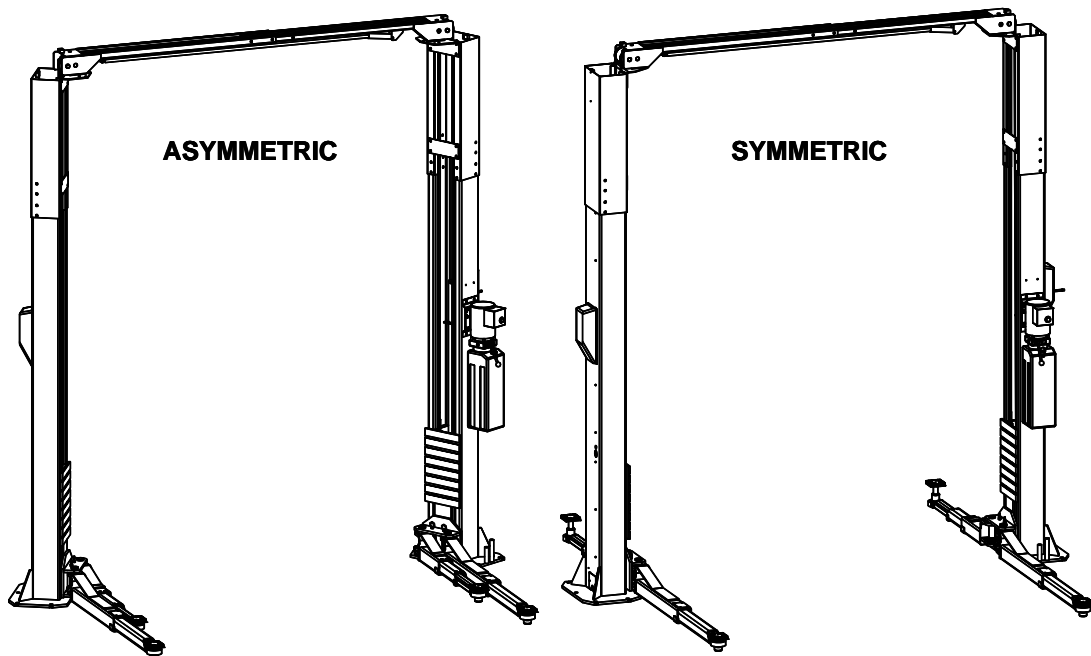

MODEL VS10

(This Lift may be installed either symmetrically or asymmetrically)

10,000 LBS. CAPACITY
2500 LBS. PER ARM

200 Cabel Street, P.O. Box 3944 Louisville, Kentucky 40201-3944

Email: sales@challengerlifts.com Web site: www.challengerlifts.com

Office 800-648-5438 / 502-625-0700 Fax 502-587-1933

**IMPORTANT: READ THIS MANUAL COMPLETELY BEFORE
INSTALLING or OPERATING LIFT**

GENERAL SPECIFICATIONS

See Figure 1	VS10 (Symmetric Install)	VS10 (Asymmetric Install)
A Rise Height *	76" (1931mm)	76" (1931mm)
B Overall Height (Adjustable)	143 1/2" / 149 1/2" (3645mm/3795mm)	143 1/2" / 149 1/2" (3645mm/3795mm)
C Cylinder Height	145 1/2" (3693mm)	145 1/2" (3693mm)
D Overall Width (Adjustable)	131" / 136 3/4" (3324mm/3474mm)	132" / 138" (3355mm/3505mm)
E Drive-Thru Clearance	92 1/2" / 98 1/4" (2347mm/2497mm)	86" / 92" (2182mm/2332mm)
F Floor to Overhead Switch	138" / 144" (3504mm/3654mm)	138" / 144" (3504mm/3654mm)
G Short Arm Reach	22 1/8" / 41 1/2" (562mm-1055mm)	22 1/8" / 41 1/2" (562mm-1055mm)
H Long Arm Reach	38 1/2" / 61 1/2" (979mm-1565mm)	38 1/2" / 61 1/2" (979mm-1565mm)
K Screw Pad Height	3 7/8" – 7 1/8" (100mm-181mm)	3 7/8" – 7 1/8" (100mm-181mm)
L Inside of Columns	104 1/2" / 110 1/2" (2654mm/2804mm)	96" / 102" (2440mm/2590mm)
Lifting Capacity **	10,000 lbs. (4536 kg)	10,000 lbs. (4536 kg)
Ceiling Height Required	150 1/2" (3825mm)	150 1/2" (3825mm)
Motor	2HP, Single Phase, 60Hz	2HP, Single Phase, 60Hz
Voltage	208-230	208-230
Speed of Rise ***	60 seconds	60 seconds
Max Load Per Arm	2500 lbs (1134 kg)	2500 lbs (1134 kg)

* Rise Height measured with footpads in the highest position.

** Lift capacity ratings are based on loads equally distributed on all four arms.

*** Lifting and lowering speeds may vary depending on the weight of the vehicle.

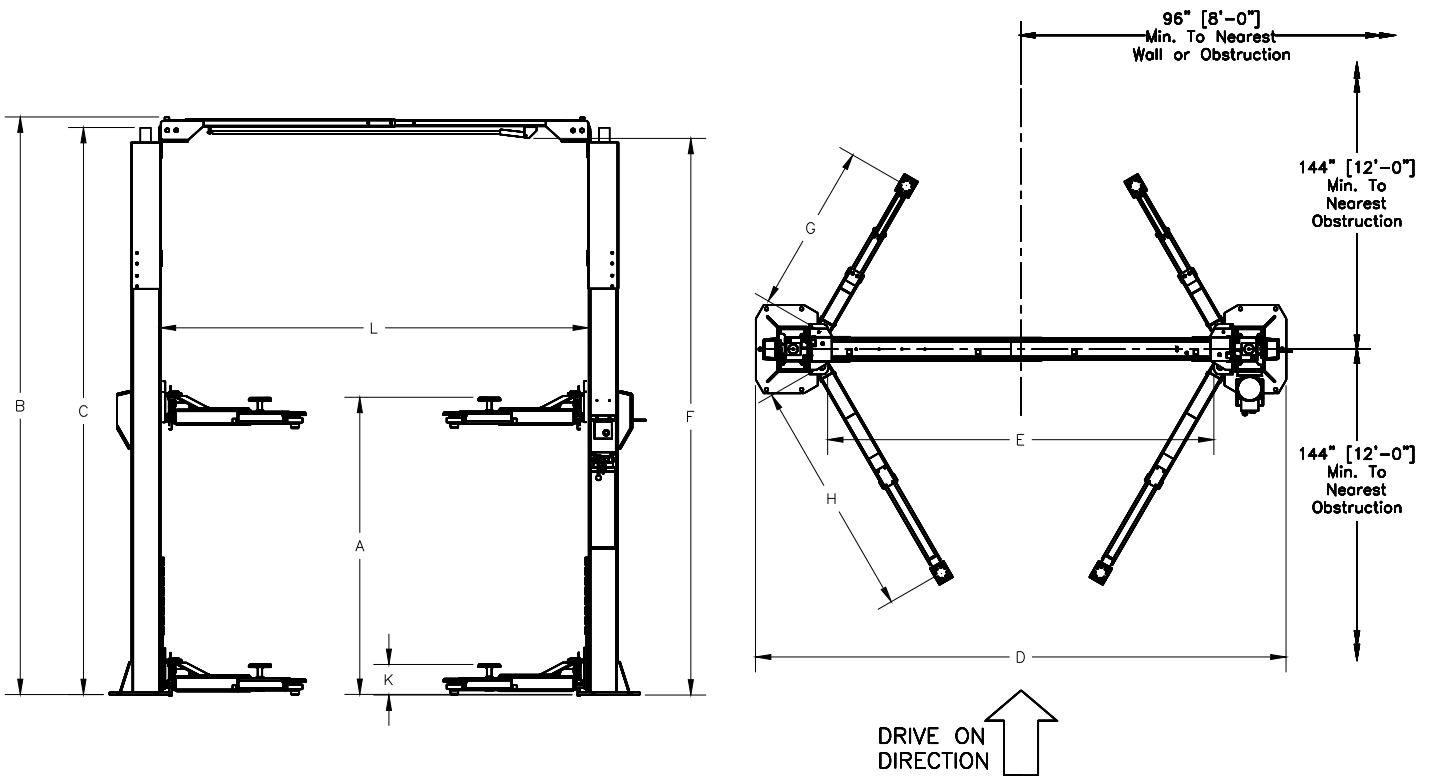

Fig 1 - General Specifications / Service Bay Layout

VERTICAL CLEARANCE

Check the height of the area where the lift is to be installed. Clearance should be calculated based on the full raised height of the lift.



WARNING Failure by purchaser to provide adequate clearance could result in unsatisfactory lift performance, property damage, or personal injury.

FLOORING

Be certain you have the proper concrete floor to properly handle the loaded lift. Floor should be in generally good condition with no large cracks, spalling or deterioration.

Minimum requirements for concrete are 4 inches minimum depth, with steel reinforcement, 3500 psi, cured for 28 days per local commercial practice. Floor should be level within 3/8 inch over the installation area. No anchors should be installed within 8 inches of any crack, edge, or expansion joint. If these conditions cannot be met, a pad may be poured to accommodate the lift.

Check with local building inspectors and/or permits office for any special instructions or approvals required for your installation.



WARNING Failure by purchaser to provide the recommended mounting surface could result in unsatisfactory lift performance, property damage, or personal injury.

LOCATION

This lift has been evaluated for indoor use only with an operating ambient temp. range of 5 – 40°C (41– 104°F)

ELECTRICAL REQUIREMENTS

For lift installation and operation for single phase units, it is necessary to have a dedicated circuit with a double pole 25 amp circuit breaker or time delay fuse.

SAFETY NOTICES AND DECALS

For your safety, and the safety of others, read and understand all of the safety notices and decals included here.

READ ENTIRE MANUAL BEFORE ASSEMBLING, INSTALLING, OPERATING, OR SERVICING THIS EQUIPMENT. PROPER MAINTENANCE AND INSPECTION IS NECESSARY FOR SAFE OPERATION. DO NOT OPERATE A DAMAGED LIFT.

Safety decals similar to those shown here are found on a properly installed lift. Be sure that all safety decals have been correctly installed on the Power Unit reservoir. Verify that all authorized operators know the location of these decals and fully understand their meaning. Replace worn, faded, or damaged decals promptly.



WARNING Do not attempt to raise a vehicle on the lift until the lift has been correctly installed and adjusted as described in this manual.

<p>SAFETY INSTRUCTIONS Read operating and safety manuals before using lift.</p>	<p>SAFETY INSTRUCTIONS Proper maintenance and inspection is necessary for safe operation.</p>	<p>If attachments, accessories or configuration modifying components that are located in the load path, affect operation of the lift, affect the lift electrical listing or affect intended vehicle accommodation are used on this lift and, if they are not certified for use on this lift, then the certification of this lift shall become null and void. Contact the participant for information pertaining to certified attachments, accessories or configuration modifying components.</p> <p>SAFETY INSTRUCTIONS</p> <p>load path, affect operation of the lift, affect the lift electrical listing or affect intended vehicle accommodation are used on this lift and, if they are not certified for use on this lift, then the certification of this lift shall become null and void. Contact the participant for information pertaining to certified attachments, accessories or configuration modifying components.</p> <p>www.autolift.org ©2007 by ALI, Inc. ALI/WLSIAO1</p>
<p>SAFETY INSTRUCTIONS Do not operate a damaged lift.</p>	<p>The messages and pictographs shown are generic in nature and are meant to generally represent hazards common to all automotive lifts regardless of specific style.</p> <p>Funding for the development and validation of these labels was provided by the Automotive Lift Institute, PO Box 33116 Indianapolis, FL 32903</p> <p>They are protected by copyright. Set of labels may be obtained from ALI or its member companies.</p> <p>© 1992 by ALI, Inc. ALI/WLSIAO1</p>	

<p>CAUTION Lift to be used by trained operator only.</p>	<p>CAUTION Authorized personnel only in lift area.</p>	<p>WARNING Clear area if vehicle is in danger of falling.</p>	<p>WARNING Position vehicle with center of gravity midway between adapters.</p>
<p>CAUTION Use vehicle manufacturer's lift points.</p>	<p>CAUTION Always use safety stands when removing or installing heavy components.</p>	<p>WARNING Remain clear of lift when raising or lowering vehicle.</p>	<p>WARNING Avoid excessive rocking of vehicle while on lift.</p>
<p>CAUTION Use height extenders when necessary to ensure good contact.</p>	<p>CAUTION Auxiliary adapters may reduce load capacity.</p>	<p>WARNING Do not override self-closing lift controls.</p>	<p>WARNING Keep feet clear of lift while lowering.</p>
<p>The messages and pictographs shown are generic in nature and are meant to generally represent hazards common to all automotive lifts regardless of specific style.</p> <p>Funding for the development and validation of these labels was provided by the Automotive Lift Institute, PO Box 33116 Indianapolis, FL 32903.</p> <p>They are protected by copyright. Set of labels may be obtained from ALI or its member companies.</p> <p>© 1992 by ALI, Inc. ALI/WLSIAO1</p>		<p>The messages and pictographs shown are generic in nature and are meant to generally represent hazards common to all automotive lifts regardless of specific style.</p> <p>Funding for the development and validation of these labels was provided by the Automotive Lift Institute, PO Box 33116 Indianapolis, FL 32903.</p> <p>They are protected by copyright. Set of labels may be obtained from ALI or its member companies.</p> <p>© 1992 by ALI, Inc. ALI/WLSIAO1</p>	

RECEIVING

The shipment should be thoroughly inspected as soon as it is received. The signed bill of lading is acknowledgement by the carrier of receipt in good condition of shipment covered by our invoice.

If any of the goods called for on this bill of lading are shorted or damaged, do not accept them until the carrier makes a notation on the freight bill of the shorted or damaged goods. Do this for your own protection.

NOTIFY **Challenger Lifts** AT ONCE if any hidden loss or damage is discovered after receipt.

IT IS DIFFICULT TO COLLECT FOR LOSS OR DAMAGE AFTER YOU HAVE GIVEN THE CARRIER A CLEAR RECEIPT.

File your claim with **Challenger Lifts** promptly. Support your claim with copies of the bill of lading, freight bill, and photographs, if available.

Component Packing List

PART #	QTY/ LIFT	DESCRIPTION
VS10-004	1	Power Column Ass'y
VS10-005	1	Idler Column Ass'y
VS10-006	1	Overhead Ass'y
VS10-001	1	Hardware Box
VS10-13-01	2	Column Extension
VS10-31-00	2	Rear Arm Ass'y
VS10-32-00	2	Front Arm Ass'y
VS10-011	2	Synchronizer Cable Ass'y
VS10-012	1	Hydraulic Hose Pack
VS10-10-07-B	1	Power Lock Cover
VS10-11-02	1	Idler Lock Cover

INSTALLATION

IMPORTANT: Always wear safety glasses while installing lift.

TOOLS (MINIMUM REQUIRED)

- a. Tape measure, 16ft
- b. Chalk line
- c. 4ft level
- d. 10" adjustable wrench
- e. Metric open end wrenches 10mm, 13mm, 14mm, 15mm, 17mm, 18mm, 19mm and 24mm
- f. Needle Nose pliers
- g. Snap Ring pliers
- h. Screw Drivers (Flat and Phillips)
- i. Hammer drill with 3/4" diameter carbide tipped bits
- j. 2lb hammer
- k. Torque wrench: 150 foot pounds minimum with 1 1/8" socket
- l. 12 ft. Step ladder
- m. Anti-Seize lubricant (for arm pins and foot pad screw threads and stop rings)

LAYOUT

- 1) Layout the service bay according to the architect's plans or owners instructions (**see Fig 1**). **Failure to install in this orientation can result in personal and property damage.** Be certain that the proper conditions exist, see page 3.
- 2) Assemble column extension and cross strap to each column using (12 sets) M12 x 35 Hex bolts, flat washers, lock washers and nuts. Repeat for opposite column and extension. (Note: When set in lower position only 8 sets of hardware are used). Refer to **Fig 2** below.

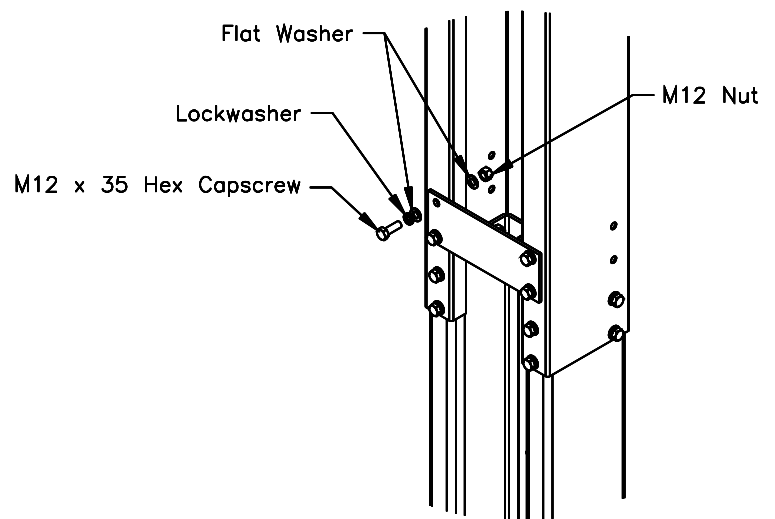

Fig 2 - Column Extension

- Refer to **Fig 1**. Using the Overall Width (C) Dimension, chalk two parallel lines (A & B) on the floor within 1/8" tolerance. Chalk a third line (C) perpendicular to lines A & B to designate fore and aft location. Erect both column assemblies. Align the base plate edges to the chalk lines as seen in **Fig 3** below.

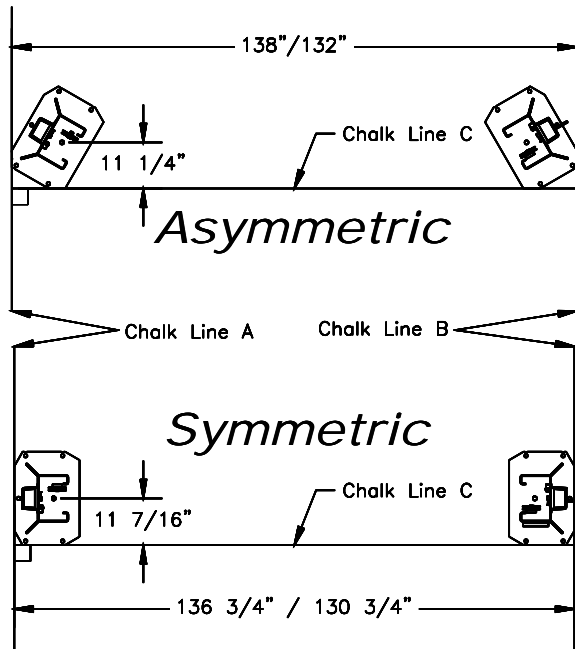

Fig 3 - Layout

ANCHORING

- The anchor bolts must be installed at least 8" from any crack, edge, or expansion joint.
- Use a concrete hammer drill with a 3/4 inch carbide bit. Tip diameter should conform to ANSI Standard B94.12-1977 (.775 to .787). Do not use excessively worn bits or bits which have been incorrectly sharpened. A core bit may be necessary if an obstruction is encountered. **Never substitute with shorter anchor.**
- Recheck "Overall Width" dimension, **Fig 1**. Drill the anchor holes (Power Column Only) using the base plate as a template. Drill through the floor if possible or to a depth of 5 inches minimum.
- Vacuum dust from the hole for proper holding power.
- Shim column to plumb using the shims provided as shown in **Fig 4**. **DO NOT** shim more than 1/2" at any given point. Use a level no less than 24" in length to plumb columns.
- Assemble washer and nut to anchor with nut just below impact section of bolt. Drive anchor into hole until nut and washer contact base.

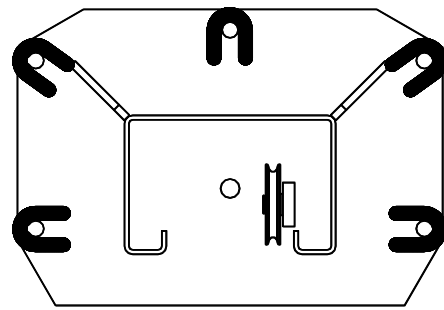

Fig 4 - Column Shimming

- Tighten power column anchors and recheck column for plumb. Re-shim if necessary. Torque to 150 foot-pounds to set anchors.

OVERHEAD

SYMMETRIC

- For Asymmetric installation, skip to Step 12.
- The Overhead is packaged in the Narrow setting. Remove the M12 hardware and re-assemble at the desired width. The M12 hardware must be assembled as shown to avoid interference with the synchronizing cables. Assemble the overhead shutoff bar, mercury switch, bracket and mounting plates as seen in **Fig 5**.

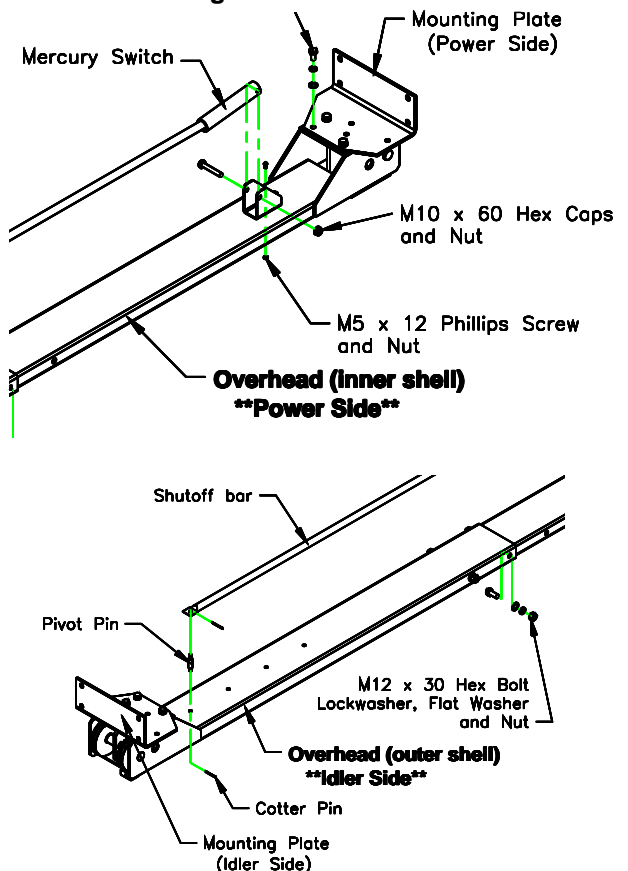

Fig 5 - Symmetric Overhead Assembly

ASYMMETRIC

- 13) The Overhead is packaged in the Narrow setting. Remove the M12 hardware and re-assemble at the desired width. The M12 hardware must be assembled as shown to avoid interference with the synchronizing cables. Assemble the overhead shutoff bar, mercury switch, bracket and mounting brackets as seen in Figs 5 & 6.

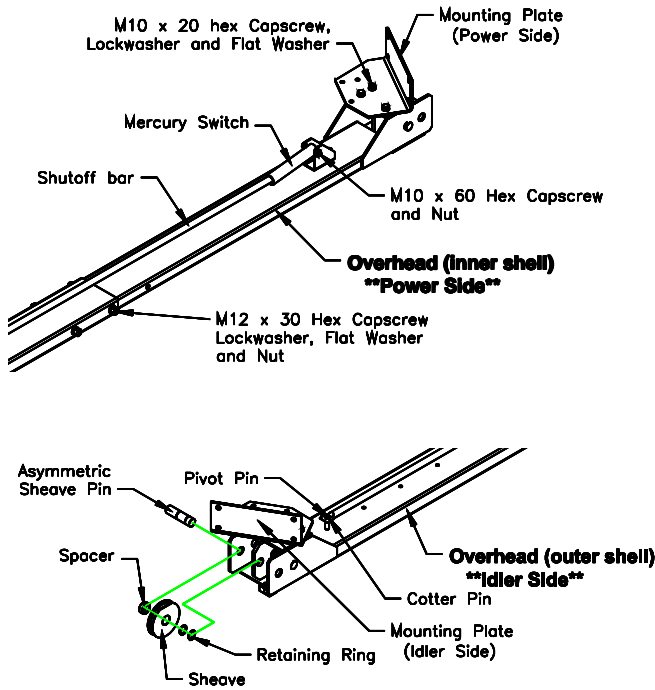

Fig 6 – Asymmetric Overhead Assembly

- 14) Remove the pre-assembled Symmetric Sheave Pin, Sheave and Spacers. Re-assemble the Sheaves, Spacers using the Asymmetric Sheave Pins and Snap rings provided. The Asymmetric Sheave Pin has 2 Snap Ring grooves; the end with the Snap Ring groove nearest should be inserted first. Refer to Figs 6 and 7.

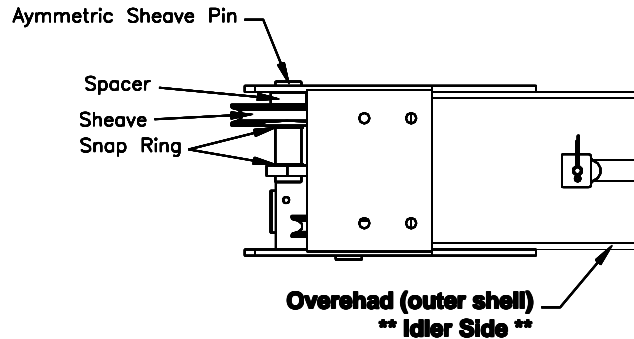

Fig 7 – Asymmetric Sheave Assembly
(Mounting Plate Removed for Clarity)

- Raise and install the Overhead Assembly using M12 x 35 Hex Bolts, lock washers, flat washers and nuts. See Fig 8 below.

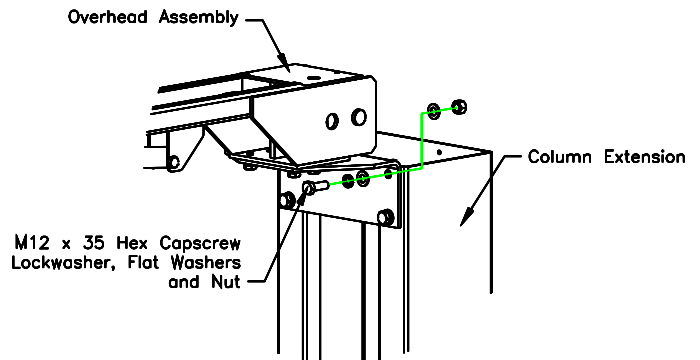

Fig 8 – Overhead Installation

- 15) Route the Mercury switch cord through the end of the overhead and down the outside of the power column as shown in Fig 9.

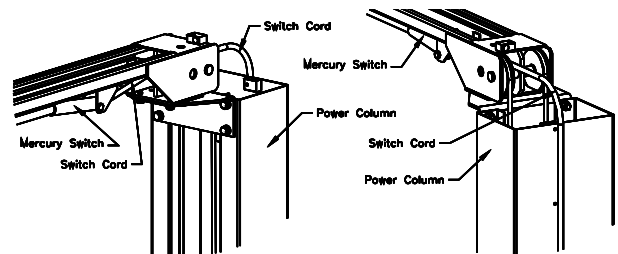

Fig 9 –Limit Switch Cord Routing

- 16) Check idler column shimming. Use additional shims (see Fig. 4) to remove any gaps that may have been created while installing overhead beam. Repeat steps 6-10 for the Idler Side Column anchoring.

HYDRAULIC HOSE ROUTING

17) The Hydraulic hoses are pre-routed in each column. Uncoil the hoses at the top of each column and route through the guides in the column extension, over the ends of the overhead and through the guides of the overhead. Join these hoses with the hydraulic union supplied. Tie the hoses to the guides in the overhead. Refer to **Fig 10** below.

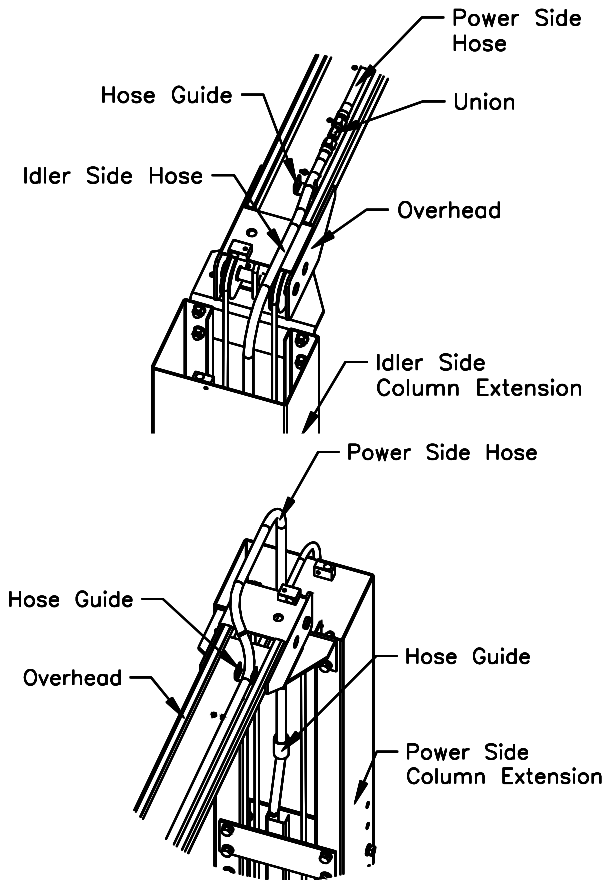

Fig 10 – Hydraulic Hose Routing

SYNCHRONIZER CABLES

- 18) Manually raise each carriage into the second lock position.
- 19) Attach one end of synchronizing cable to carriage. See **Fig 11a** for proper attachment.
- 20) Secure the cables with the nut and jam nut provided, **Fig 11c**.
- 21) Route cable up and over sheave in overhead. Follow across to other sheave on opposite column. Route down through carriage to sheave in bottom of column. Route under sheave and up to cable attachment. Use **Fig 11a** for proper attachment.
- 22) The sheaves have a cable trapping tab that will need to be removed before routing the cables and reattached after. **Fig 11b**

23) Repeat for opposite side.

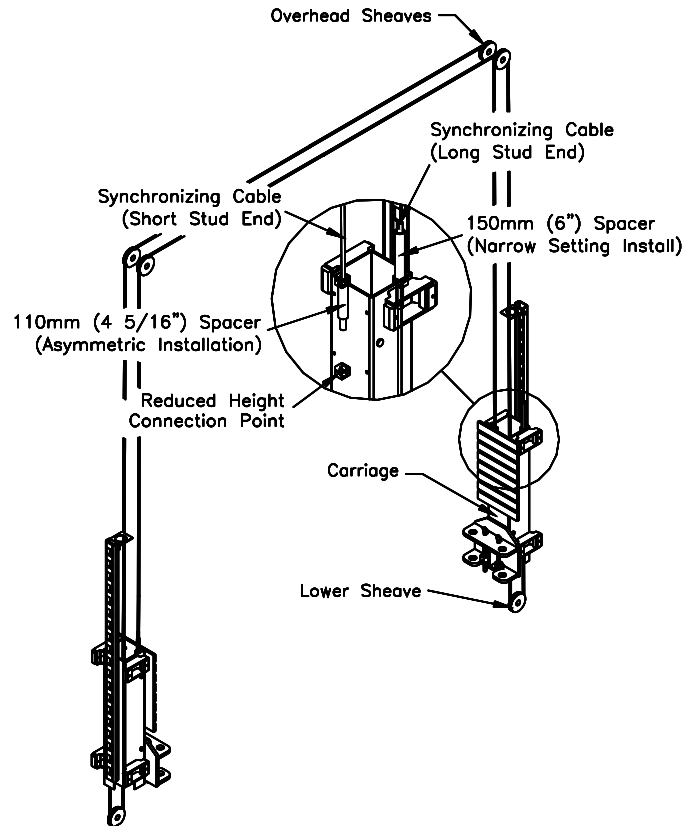

Fig 11a – Synchronizing Cables

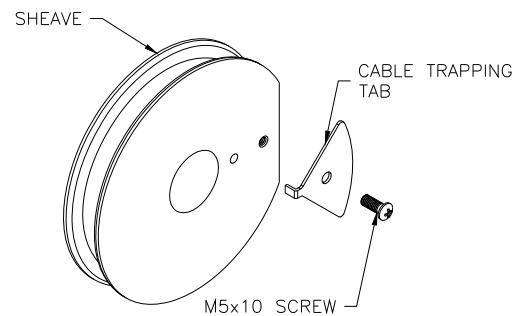

Fig 11b-Cable Trapping

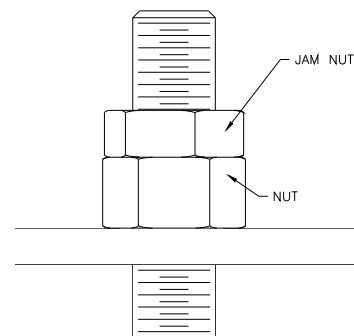

Fig 11c-Cable Trapping

LOCK RELEASE

- 24) While the carriages are still sitting in the locks from the previous steps and starting with the Idler Side, route the Mechanical Lock Release Cable Assembly (Loop End) through the column opening, around the pulley and attach to the lock release cam as seen in **Fig 12**.
- 25) Continue routing the cable up the inside of the Idler Column and extension. Attach two Guide Blocks, one to the top of the Column Extension and the other to the Overhead using the M6 x 25 Hex Capscrews provided. Refer to **Fig 12**.
- 26) Route the Lock Release Cable over the top of the overhead diagonally to the top of the Power Column. Attach two Guide Blocks, one to the top of the Column Extension and the other to the Overhead using the M6 x 25 Hex Capscrews provided. Refer to **Fig 13**.
- 27) Continue routing the cable down the inside of the Power Column and out through the column opening and around the Upper Pulley as seen in **Fig 13**.
- 28) Insert the lock release cable through one bolt of the cable clamp and loop the remaining cable around the pin of the Lock Release Cam. Insert the free end of the cable through the opposite bolt of the cable clamp. Remove all slack in the cable and tighten both clamp bolts. Refer to **Fig 13**.
- 29) Attach the Lock Release Stud and Knob to the Lock Release Cam.

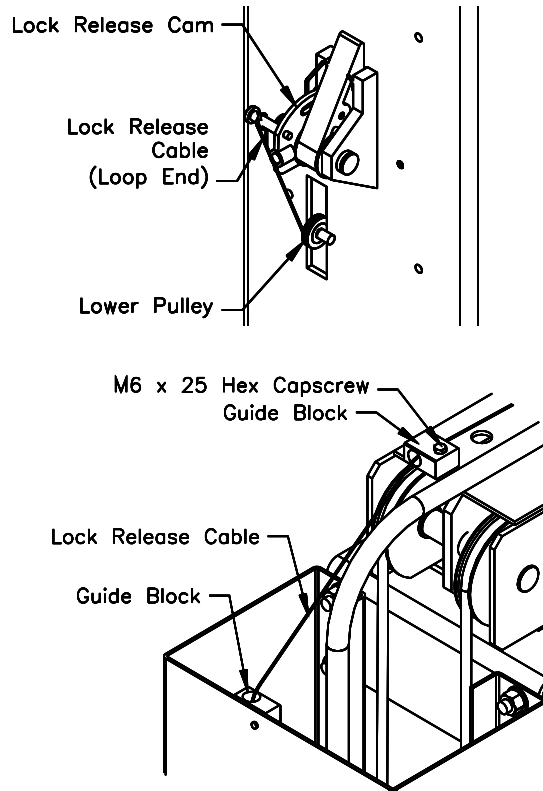

Fig 12 – Idler Side Lock Release Assembly

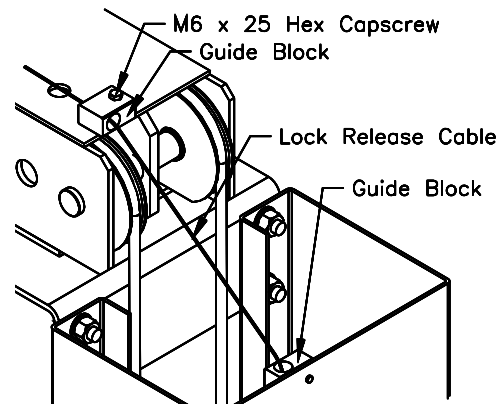
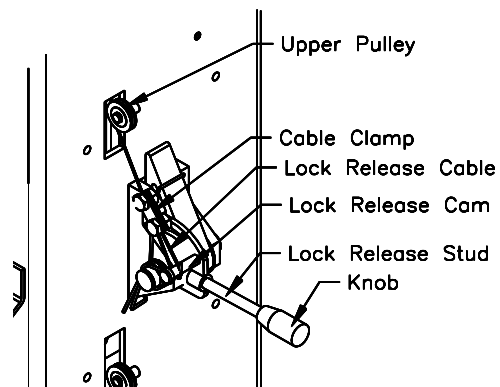

Fig 13 – Power Side Lock Release Assembly



POWER UNIT & HYDRAULIC LINES

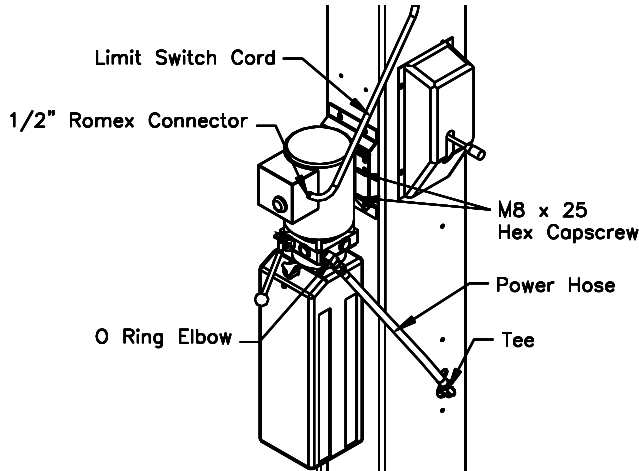

Fig 14 – Power Unit Mounting

- 30) Mount Power Unit to power column as shown in **Fig 14**. Using the (4) M8 x 25 Hex Head Capscrews provided.
- 31) Attach Hydraulic elbow fitting threading the O-Ring end into the power unit.
- 32) Thread the straight end of the Power Hose to the elbow in the Power Unit and connect the opposite end to the preassembled Tee extending out the back of the column.

BE CERTAIN ALL FITTINGS AND CONNECTIONS ARE TIGHT. IT IS THE INSTALLERS RESPONSIBILITY TO INSURE THE SYSTEM IS LEAK-FREE. Fill the Power Unit with three gallons of clean 10wt anti-foam, anti-rust hydraulic oil or Dexron III ATF. **DO NOT USE OILS WITH DETERGENTS.**

ARM INSTALLATION

- 33) Remove each Snap Ring and Arm Pin from the Carriage. Lubricate the arm pin or carriage arm pin hole with “anti-seize” and install the arms. Insure that the arm restraint gears engage and disengage properly. Arm restraints should disengage when lift is fully lowered. If any binding occurs, insure that the large gear mounted to the arm has been factory installed tight against the arm pin.
- 34) Extend the foot pad to both extents and apply “anti-seize” to the three retaining rings and where the double screw makes contact with the base of the foot pad.

ELECTRICAL

- 35) Refer to **Fig 16 Wiring Diagram** for all steps under this heading.

Single Phase

- 36) Connect the Overhead Limit Switch Cord to Power Unit as shown.
- 37) Connect Power Unit to suitable electrical source as shown.

Three Phase

- 38) Power unit is factory wired for 240 volt. Refer to wiring diagram or motor plate for optional voltages.
- 39) Connect Contactor Enclosure to column. Mounting hardware should be centered on the column side to side to avoid the path of the slide blocks.
- 40) Connect Overhead Limit Switch Cord to Contactor as shown.
- 41) Connect Contactor to Power unit as shown. Connect Contactor to suitable electrical source as shown.

IMPORTANT: AFTER WIRING HAS BEEN COMPLETED, TEST OPERATION OF POWER UNIT & OVERHEAD LIMIT SWITCH. WHILE RAISING LIFT, OPERATE OVERHEAD SHUTOFF BAR. POWER UNIT MOTOR SHOULD STOP WHEN SHUTOFF BAR IS RAISED.

COLUMN DECAL PLACEMENT

- 42) Center decal on idler column, opposite of the power unit.
- 43) Apply the decal 48” from the top of the base plate, **Fig 15**.

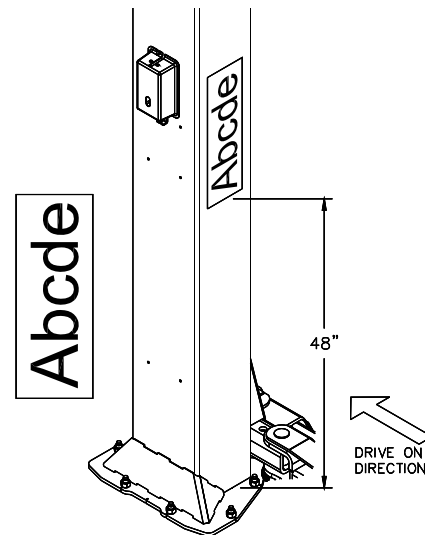

Fig 15 – Decal Placement

FINAL ADJUSTMENTS

HYDRAULICS

- 44) Pressure test hydraulic system. Energize power unit, raise lift to full rise and continue to run motor for additional 10 seconds. (NOTE: pressure relief will make a high pitch squeal sound for these 10 seconds.) Check hydraulic system for leaks.
- 45) Energize power unit again for 10 seconds. With a clean rag, wipe down both cylinder rods. (The cylinders are shipped with a small amount of clear anti-corrosive lubricant that will be forced out through the wiper when the lift reaches full rise.) **If lubricant is not wiped clean from the cylinder rod, the cylinder may appear to be leaking.**

SYNCHRONIZING CABLES

- 46) Raise lift and insure carriages lower into same lock position.
- 47) Adjust synchronizing cables so the tension is equal in both cables and carriages are firmly sitting on locks.
- 48) Cycle lift to insure that latches engage simultaneously.

LOCK RELEASE CABLE

- 49) Raise lift to a lock position but don't set into the lock. Pull and release Power Column lock release handle while watching Idler Column lock. Adjust Cable tension by removing slack and retightening cable clamp at the power side.
- 50) Install both Lock Release Covers using the M8 x 12 Phillips Screws and Washers provided.

Wiring Diagram

EACH LIFT SHOULD HAVE A DEDICATED CIRCUIT WITH A DOUBLE POLE (THREE POLE FOR 440-480V) BREAKER OR TIME DELAY FUSE SIZED ACCORDING TO THE FOLLOWING CHART

	1 ϕ 208-240V	3 ϕ 208V	3 ϕ 220-240V	3 ϕ 440-480V
2Hp	25amp	15amp	15amp	5amp

* WIRING MUST COMPLY WITH ALL LOCAL ELECTRICAL CODES *

FOR SINGLE PHASE

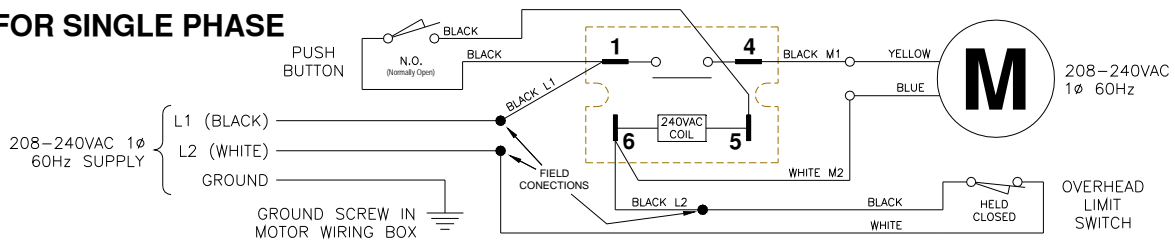

FOR THREE PHASE

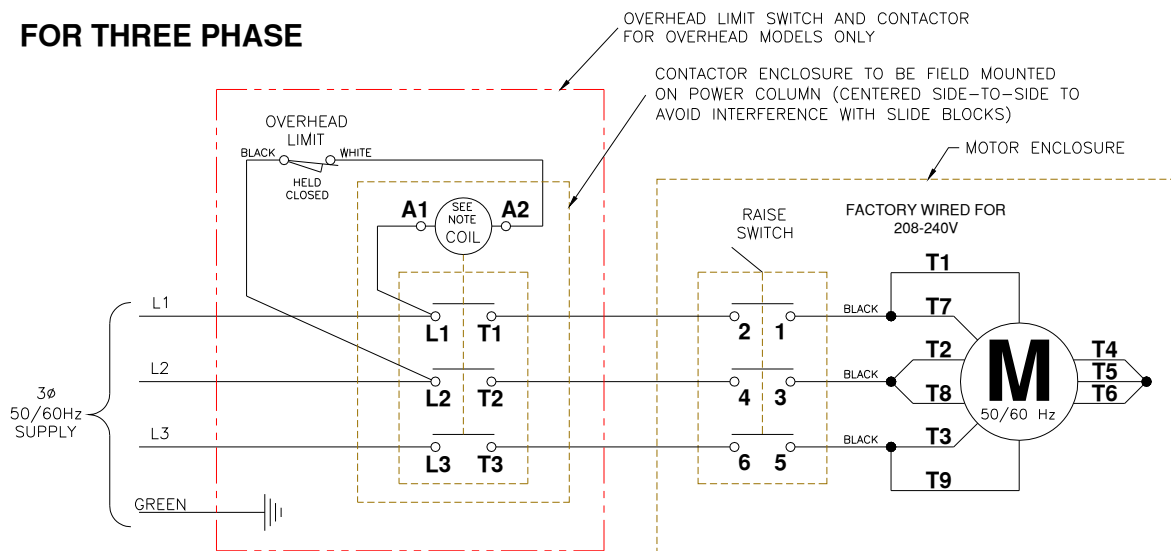

NOTES:

- 1) MOTOR IS FACTORY WIRED FOR 208V OR 220-240V SUPPLY
- 2) MOTOR CONNECTIONS MUST BE RECONFIGURED PER THIS DIAGRAM FOR 440-480V SUPPLY
- 3) CONTACTOR COIL RATING MUST MATCH SUPPLY VOLTAGE (208V, 220-240V, OR 440-480V)
- 4) CONTACTOR MUST BE FIELD MOUNTED ON POWER COLUMN (CENTERED SIDE-TO-SIDE TO AVOID INTERFERENCE WITH SLIDE BLOCKS)
- 5) MOTOR ROTATION IS COUNTER CLOCKWISE FROM TOP OF MOTOR

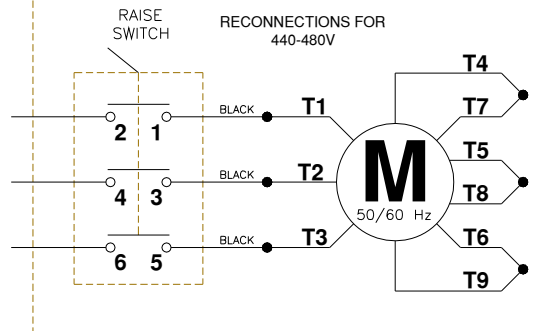

P/N 31366 1/05/02

Fig 16 – Electrical Wiring Diagram

OWNER/OPERATOR CHECKLIST

- 51) Demonstrate the operation of the lift to the owner/operator and review correct and safe lifting procedures using the **Lifting It Right** booklet as a guide.
- 52) Complete the Installation Checklist/Warranty Validation questionnaire with the owner. Review the terms of the warranty registration card, and return the card and a copy of the questionnaires to:

Challenger Lifts, Inc.
200 Cabel Street
Louisville, KY. 40206

OPERATION PROCEDURE

SAFETY NOTICES AND DECALS

This product is furnished with graphic safety warning labels, which are reproduced on page 3 of these instructions. Do not remove or deface these warning labels, or allow them to be removed or defaced. For your safety, and the safety of others, read and understand all of the safety notices and decals included.

OWNER/EMPLOYER RESPONSIBILITIES

This lift has been designed and constructed according to ANSI/ALI ALCTV-2006 standard. The standard applies to lift manufactures, as well as to owners and employers. The owner/employer's responsibilities as prescribed by ANSI/ALI ALOIM-2000, are summarized below. For exact wording refer to the actual standard provided with this manual in the literature pack.

The Owner/Employer shall insure that lift operators are qualified and that they are trained in the safe use and operation of the lift using the manufacturer's operating instructions; ALI/SM 93 -1, ALI Lifting it Right safety manual; ALI/ST-90 ALI Safety Tips card; ANSI/ALI ALOIM-2000, American National Standard for Automotive Lifts-Safety Requirements for Operation, Inspection and Maintenance; ALI/WL Series, ALI Uniform Warning Label Decals/Placards; and in case of frame engaging lifts, ALI/LP-GUIDE, Vehicle Lifting Points/Quick Reference Guide for Frame Engaging Lifts.

The Owner/Employer shall establish procedures to periodically inspect the lift in accordance with the lift manufacturer's instructions or ANSI/ALI ALOIM-2000, American National Standard for Automotive Lifts-Safety Requirements for Operation, Inspection and Maintenance; and the employer shall insure that

the lift inspectors are qualified and that they are adequately trained in the inspection of the lift.

The Owner/Employer shall establish procedures to periodically maintain the lift in accordance with the lift manufacturer's instructions or ANSI/ALOIM-2000, American National Standard for Automotive Lifts-Safety Requirements for Operation, Inspection and Maintenance; and the employer shall insure that the lift maintenance personnel are qualified and that they are adequately trained in the maintenance of the lift.

The Owner/Employer shall maintain the periodic inspection and maintenance records recommended by the manufacturer or ANSI/ALI ALOIM-2000, American National Standard for Automotive Lifts-Safety Requirements for Operation, Inspection and Maintenance.

The Owner/Employer shall display the lift manufacturer's operating instructions; ALI/SM 93 -1, ALI Lifting it Right safety manual; ALI/ST-90 ALI Safety Tips card; ANSI/ALI ALOIM-2000, American National Standard for Automotive Lifts-Safety Requirements for Operation, Inspection and Maintenance; and in the case of frame engaging lift, ALI/LP-GUIDE, Vehicle Lifting Points/Quick Reference Guide for Frame Engaging Lifts; in a conspicuous location in the lift area convenient to the operator.

IMPORTANT SAFETY INSTRUCTIONS

When using your garage equipment, basic safety precautions should always be followed, including the following:

1. Read all instructions.
2. Care must be taken as burns can occur from touching hot parts.
3. To reduce the risk of fire, do not operate equipment in the vicinity of open containers of flammable liquids (gasoline).
4. Keep hair, loose clothing, fingers, and all parts of body away from moving parts.
5. Use only as described in this manual. Use only manufacturer's recommended attachments.
6. ALWAYS WEAR SAFETY GLASSES. Everyday eyeglasses only have impact resistant lenses, they are not safety glasses.

SAVE THESE INSTRUCTIONS

LIFTING A VEHICLE

- 1) Insure that the lifting arms are parked, out to full drive thru position.
- 2) Center the vehicle between the columns in the service bay and position the vehicle's center of gravity midpoint between the columns. NOTE: the center of gravity is based on the weight distribution and is not the same as the center point of the vehicle.

DO NOT EXCEED 2500 POUNDS PER ARM.

DO NOT ATTEMPT TO LIFT A VEHICLE WITH ONLY ONE OR TWO ARMS, AS THIS WILL VOID THE WARRANTY

INSURE THAT THE HIGHEST POINT ON THE VEHICLE WILL CONTACT THE OVERHEAD LIMIT SWITCH BAR.

DO NOT PLACE THE VEHICLE IN THE SERVICE BAY BACKWARDS.

REFER TO THE VEHICLE MANUFACTURERS SERVICE MANUAL, TECHNICAL BULLETINS, "VEHICLE LIFTING POINTS GUIDE" (ALI/LP-GUIDE) OR OTHER PUBLICATIONS TO LOCATE THE RECOMMENDED LIFTING POINTS.

- 3) Position the arms and adapters so all four pads contact the vehicle simultaneously.

The vehicle should remain level during lifting.

- 4) Raise the lift until all four wheels are off the ground. Test the stability of the vehicle by attempting to rock the vehicle. Check adapters for secure contact with vehicle lift points. If the vehicle seems unstable, lower the lift and readjust the arms. If the vehicle is stable, raise the vehicle to a height a few inches above the desired working height.
- 5) Lower the vehicle until the safety latches on both columns engage. The vehicle should remain level when both latches are engaged. If one side engages and the other continues to descend, stop lowering the vehicle, raise it several inches, and try again to engage both latches.

Always lower lift into locks before entering the area beneath the vehicle.

Always use safety stands when removing or installing heavy components.

LOWERING A VEHICLE

- 1) Insure that the area under the vehicle is clear of personnel and tools.
- 2) Raise the vehicle until both latches are free.
- 3) Disengage the latches by pulling down and holding the lock release lever.
- 4) Lower the vehicle by depressing the lowering valve handle.
- 5) Continue to lower the vehicle until the carriages stop against the base plate. Retract the extension arms, and park them.

MAINTENANCE

To avoid personal injury, permit only qualified personnel to perform maintenance on this equipment. Maintenance personnel should follow lockout/tagout instructions per ANSI Z244.1.

The following maintenance points are suggested as the basis of a routine maintenance program. The actual maintenance program should be tailored to the installation. See ANSI/ALI ALOIM booklet for periodic inspection checklist and maintenance log sheet.

- If lift stops short of full rise or chatters, check fluid level and bleed both cylinders per Installation Instructions.
- Replace all Safety, Warning or Caution Labels if missing or damaged (**See *Installation instructions page 3.***)

Daily

- Keep lift components clean.
- Check for loose or broken parts.
- Check hydraulic system for fluid leaks.
- Check adapters for damage or excessive wear. Replace as required with genuine Challenger Lifts parts.
- Check lock release activation. When properly adjusted, the idler column lock should rest firmly against the back of the column when engaged and pull clear of the column back when disengaged.

Weekly

- Check synchronizer cables and sheaves for wear. Replace as required with genuine Challenger Lifts parts.
- Check lock release cable adjustment per Installation Instructions step 44.
- Check synchronizer cable tension per Installation Instructions. Adjust if necessary.

Monthly

- Torque concrete anchor bolts to 80 ft-lbs.
- Check overhead shutoff switch. While raising lift, operate overhead shutoff bar. Power Unit motor should stop when bar is raised.
- Lubricate carriage slide tracks with heavy viscous grease. (Grease all (4) corners of both columns.)
- Visually inspect concrete floor for cracks and/or spalls within 12" of base plate

If any problems are encountered, contact your local Challenger Service Representative.

NOTES

Model VS10
Installation, Operation and Maintenance
PARTS BREAKDOWN

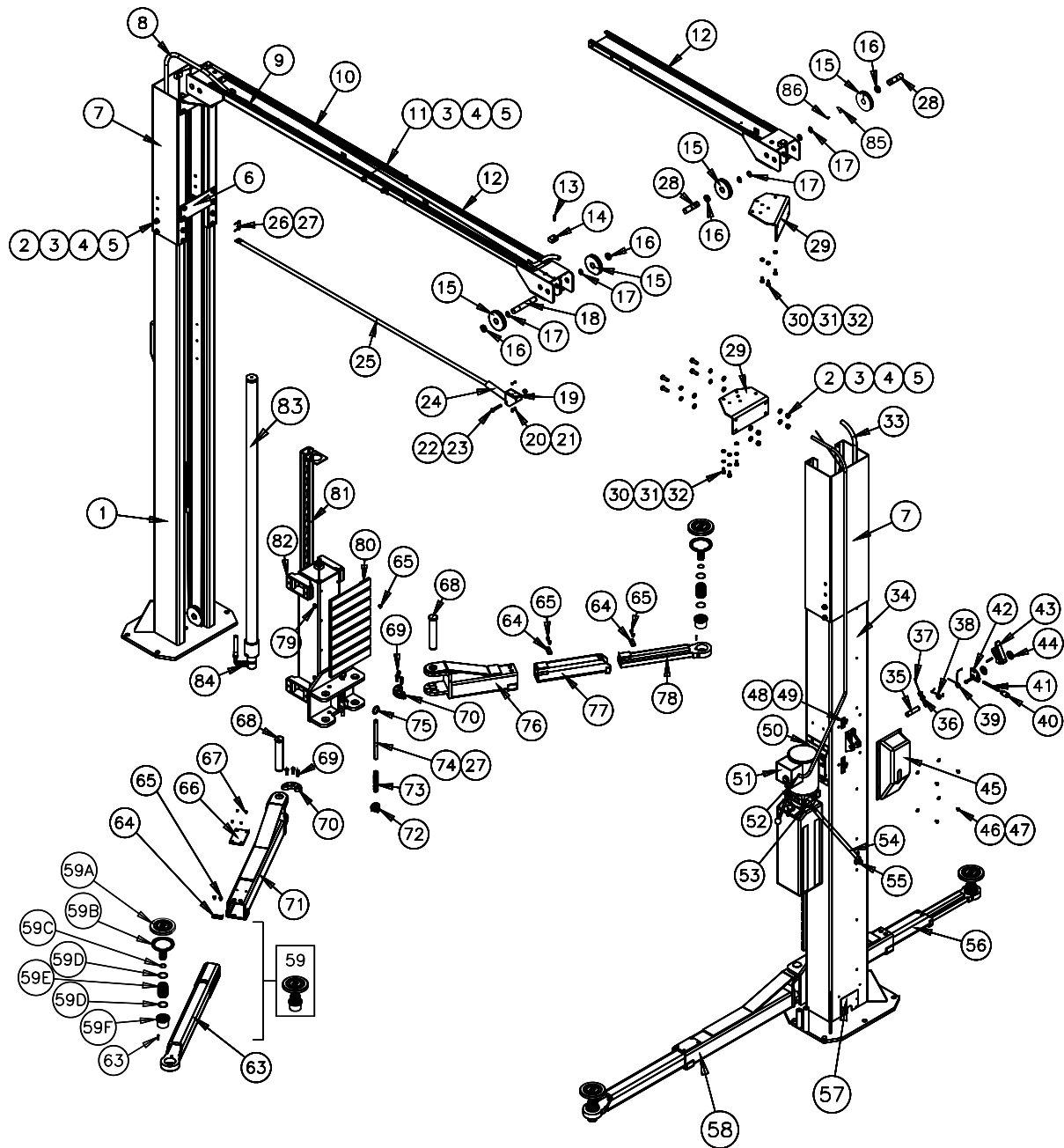

Model VS10
Installation, Operation and Maintenance

Item #	Part Number	Qty	Description	Item #	Part Number	Qty	Description
1	VS10-11-00	1	Idler Column Weld	46	VS10-10-25	8	M8 Phillips Pan Head Screw
2	VS10-40-13	32	M12 x 35 HHCS	47	VS10-10-26	8	8mm Flat Washer
3	X10-039	36	12mm Lock Washer	48	VS10-10-04	2	Lock Release Pulley
4	X10-038	68	12mm Flat Washer	49	VS10-10-27	2	9mm Snap Ring
5	X10-040	36	M12 Hex Nut	50	VS10-10-02-00	1	Power Unit Bracket
6	VS10-15	2	Support Strap	51	31368-19	1	Power Unit
7	VS10-13-01	2	Column Extension Weld	52	31060	1	1/2" Romex Connector
8	VS10-50-14	1	Idler Side Hydraulic Hose #6 JIC	53	VS10-50-17	1	Hydraulic Elbow (Power Unit)
9	VS10-50-20	1	Hydraulic Union #6 JIC	54	VS10-50-11	1	Power Unit Hydraulic Hose #6 JIC
10	VS10-40-02-00	1	Idler Side (Outer) Overhead Weld	55	VS10-50-19	1	Hydraulic Tee
11	VS10-40-17	4	M12 x 25 HHCS	56	VS10-39-00	2	Front Arm Assy. (Items 64, 65, 69, 70, 76, 77, 78, 85)
12	VS10-40-01-00	1	Power Side (Inner) Overhead Weld	57	VS10-10-09	2	Rear Access Cover
13	VS10-40-20	4	M6 x 25 HHCS	58	VS10-31-00A	2	Rear Arm Assy. (63, 64, 65, 66, 67, 69, 70, 71, 85)
14	VS10-10-18	4	Lock Release Cable Guide	59	B2250	4	Food Pad Assembly (items 59A-F)
15	VS10-40-04-B	6	Synchronizing Sheave	59A	B2208	4	Rubber insert
16	VS10-40-05	2	Sheave Spacer, Power Side (8mm)	59B	B2205	4	Food Pad Weld
	VS10-40-09	2	Sheave Spacer, Idler Side (12mm)	59C	B17256	4	2 x 30mm Round Wire Retaining Ring
17	VS10-35-06	8/12	25mm Snap Ring (Symmetric / Asymmetric)	59D	B17257	8	3 x 45mm Round Wire Retaining Ring
18	VS10-40-08	2	Overhead Sheave Axle (Symmetric)	59E	B14254	4	Threaded Sleeve
19	VS10-40-21	1	Limit Switch Bracket	59F	B17276-1	4	Threaded Insert
20	VS10-40-18	2	#10-32 x 1/2 Phillips Pan Head Screw	60	B2211	4	Roll Pin, 6mm DIA x 30mm Lg.
21	VS10-40-19	2	#10-32 Nylon Lock Nut	63	VS10-31-02-00A	2	Rear Male Arm
22	A1157	1	3/8-16 x 2 1/2 Hex Flange Head Capscrew	64	VS10-31-05	6	Stop Plate
23	A1154	1	3/8-16 Hex Flange Nut	65	VS10-31-08	24	M8 x 12 Flat Head Screw Grade 10.8
24	36027	1	Mercury Switch	66	VS10-31-03	2	Rubber Pad (Rear Female Arm)
25	VS10-40-07	1	Shutoff Bar	67	VS10-31-06	8	M5 x 8 Flat Head Screw
26	VS10-40-03	1	Shutoff Pivot Pin	68	VS10-33-A	4	Arm Pin
27	VS10-20-11	6	3mm x 26mm Cotter Pin	69	X10-077	12	M10 x 25 Allen Head Bolt

Model VS10
Installation, Operation and Maintenance

28	VS10-40-12	4	Overhead Sheave Axle (Asymmetric)	70	VS10-31-04	4	Arm Restraint Gear (Large)
29	VS10-40-10	1	Overhead Mounting Bracket (Power Side)	71	VS10-31-01-00	2	Rear Female Arm Weld
	VS10-40-11	1	Overhead Mounting Bracket (Idler Side)	72	VS10-20-03	4	Arm restraint Geat (Small)
30	B1153	6	M10 x 19 HFHCS		VS10-20-10	4	5mm x 40mm Roll Pin
31	X10-074	6	10mm Lock Washer	73	VS10-20-05	4	Arm Restraint Spring
32	X10-073	18	10mm Flat Washer	74	VS10-20-06-02	4	Arm Restraint Shaft
33	VS10-50-13	1	Power Side Hydraulic Hose #6 JIC	75	VS10-20-06-01	4	Pull Ring (Arm Restraint)
	VS10-50-12	1	Power Cylinder Hydraulic Hose #6 JIC	76	VS10-39-01-00	2	Front Female Arm Weld
34	VS10-10-01-00	1	Power Column Weld	77	VS10-39-02-00	2	Front Intermediate Arm Weld
35	VS10-10-11	2	Lock Shaft	78	VS10-39-03-00	2	Front Male Arm Weld
36	VS10-10-13-00	1	Cable Clamp	79	VS10-20-09	8	Nylon Screw
37	VS10-10-21	1	Lock Release Cable	80	VS10-20-02	2	Door Guard
38	VS10-10-16	2	Lock Spring (Cam)	81	VS10-20-01-00	2	Carriage
39	VS10-10-15	2	Lock Spring (Pawl)	82	VS10-20-04	16	Slide Block
40	VS10-10-22	1	Lock Release Knob	83	VS10-50-03-00	2	Hydraulic Cylinder
41	VS10-10-10	1	Lock Release Stud	84	VS10-50-18-00	2	Flow Control Valve #6 JIC
42	VS10-10-03-00	1	Lock Release Cam (Power Side)	85	VS10-10-16-B	6	Cable Trapping Tab
	VS10-11-03-00	1	Lock Release Cam (Idler Side)	86	X10-065	6	M5 x 10 Screw
43	VS10-10-05	2	Lock Pawl	Items Not Identified			
	VS10-10-17	2	Lock Pawl Pad		VS10-10-06	2	Synchronizing Cable
	X10-027	1	6mm x 40mm Roll Pin		VS10-10-12	2	Narrow Setting Cable Spacer
44	VS10-10-23	4	Spacer		VS10-10-19	1	Asymmetric Setting Cable Spacer
45	VS10-10-07-B	1	Lock Cover (Power Side)		VS10-10-20	6	Hose Guard
	VS10-11-02	1	Lock Cover (Idler Side)				

IMPORTANT

Replace all worn or broken parts with **genuine Challenger Lifts, Inc. parts**. Contact your local Challenger Lifts parts distributor for pricing and availability. Call Challenger Lifts, Inc. at **(502) 625-0700** for the distributor in your area.