

1/2" SQ. DR.SUPER DUTY AIR IMPACT WRENCH

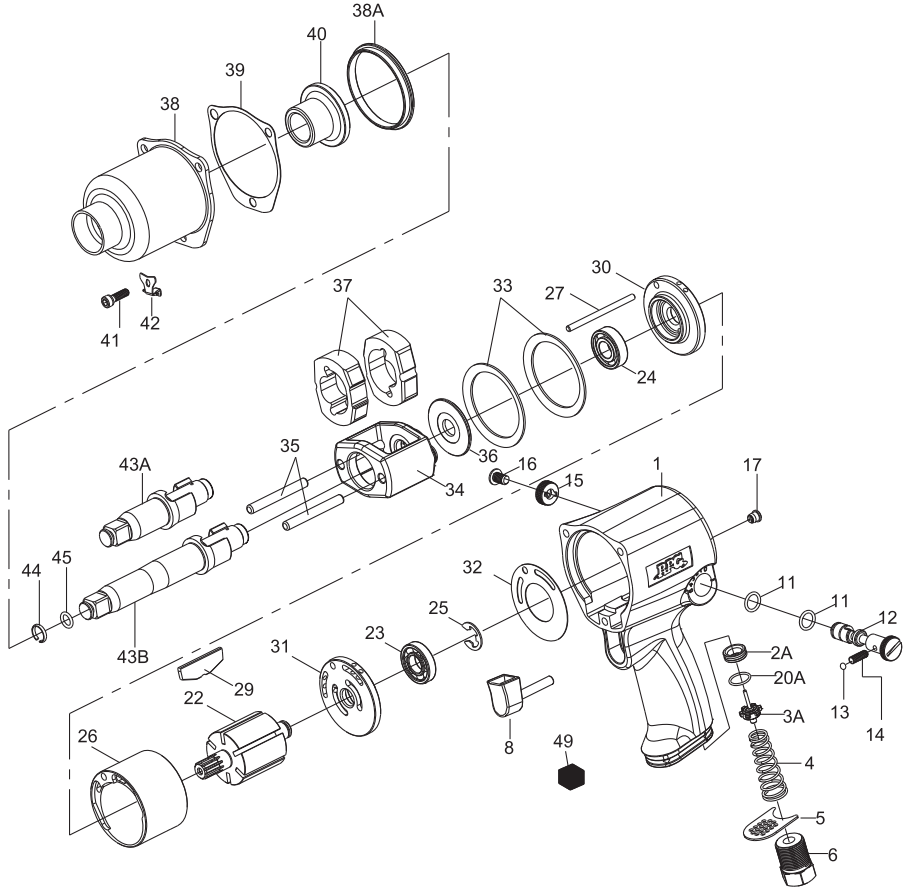

153-23120

INDEX NO.	DESCRIPTION	REQ'D NO.	INDEX NO.	DESCRIPTION	REQ'D NO.
1	Housing Assembly (incl.2A.17.20A)	1	29	Rotor Blade	6
● 2A	Throttle Valve Seat	1	30	Front End Plate	1
3A	Throttle Valve Assembly	1	31	Rear End Plate	1
4	Spring	1	32	Gasket	1
5	Exhaust Deflector	1	33	Motor Clamp Washer	2
6	Air Inlet	1	34	Hammer Frame	1
8	Trigger Assembly	1	35	Hammer Pin	2
11	O-Ring	2	36	Washer	1
12	Reverse Valve	1	37	Hammer	2
13	Steel Ball	1	38	Hammer Case	1
14	Spring	1	38A	Separator	1
15	Reverse Valve Knob	1	39	Gasket	1
16	Screw	1	40	Bushing	1
● 17	Grease Fitting	1	41	Screw	3
● 20A	O-Ring	1	42	Trigger Retainer	1
22	Rotor	1	43A	Standard Anvil Assembly (incl.44.45)	1
23	Ball Bearing	1	43B	2" Extended Anvil Assembly (incl.44.45)	1
24	Ball Bearing	1	● 44	Socket Retainer	1
25	Retainer	1	● 45	O-Ring	1
26	Cylinder	1	49	Muffler Element	1
27	Cylinder Dowel	1	TK	Tune-Up Kit { incl.4.11 (2),13.14.25.29 (6),32.39.44.45.49 }	1

● Recommended not to be purchased alone due to assembly difficulty

20141212R2