



***Model 210HP
Beadbreaker***

PARTS AND SERVICE MANUAL

IOWA MOLD TOOLING CO., INC.

BOX 189, GARNER, IA 50438-0189

TEL: 641-923-3711

TECHNICAL SUPPORT FAX: 641-923-2424

MANUAL PART NUMBER 99900657

Iowa Mold Tooling Co., Inc. is an Oshkosh Truck Corporation company.

TABLE OF CONTENTS

PARAGRAPH	TITLE	PAGE
SECTION 1. OPERATION		
1-1.	DESCRIPTION	1-1
1-2.	OPERATION	1-1
SECTION 2. SERVICE		
2-1.	GENERAL.....	2-1
2-2.	BEAD BREAKER	2-1
2-2-1.	CLAMPING CYLINDER DISASSEMBLY.....	2-1
2-2-2.	CLAMPING CYLINDER ASSEMBLY	2-1
2-2-3.	BREAKER CYLINDER DISASSEMBLY	2-2
2-2-4.	BREAKER CYLINDER ASSEMBLY	2-2
2-2-5.	PURGING OF AIR.....	2-3
2-3.	CLEANING	2-3
2-4.	STORAGE.....	2-3
2-5.	TROUBLESHOOTING	2-4
SECTION 3. PARTS		
3-1.	GENERAL.....	3-1
3-2.	ORDERING REPAIR PARTS.....	3-1
SECTION 4. OIL SPECIFICATIONS		
4-1.	OIL SELECTION	4-1
4-2.	OIL SPECIFICATIONS	4-1
4-3.	CONTAMINATION AND TESTING	4-1

LIST OF ILLUSTRATIONS

FIGURE	TITLE	PART NUMBER	PAGE
A-1.	SEQUENCE OF OPERATION		1-2
A-2.	BEAD BREAKER REFERENCE DRAWING.....		1-3
B-1.	U-CUP INSTALLATION		2-2
B-2.	TROUBLESHOOTING CHART		2-4
C-1.	BEAD BREAKER - PARTS.....	79075107	3-1
C-1A.	BEAD BREAKER - DRAWING	79075107	3-2
D-1.	HYDRAULIC OIL SPECIFICATIONS		4-1

SECTION 1. OPERATION

1-1. DESCRIPTION

The ratio of hydraulic fluid pressure generated compared to supply air pressure is 100:1. In other words, 100 PSI input air pressure equals 10,000 PSI output pressure.

The IMT 210HP Bead Breaker tool consists of two cylinders - a clamping cylinder and a breaker cylinder at a 90° angle with respect to each other. Both the clamping and bead breaking actions are performed automatically - no mid-sequence operation by the user is required.

The sequence of operation is as follows (refer to Figure A-1).

STEP 1.

A air/hydraulic pump supplies the hydraulic fluid pressure to the clamping cylinder. Fluid pressure is restricted to the clamping cylinder by spring pressure on the sequence ball and by the mated surfaces of the fluid return ball and its seat. As the clamping rod moves out of the cylinder, the jaw clamps firmly on the rim.

STEP 2.

The internal hydraulic pressure of the clamping cylinder is sufficient to overcome the spring pressure against the sequence ball (approximately 2500 PSI). The ball is forced away from the seat and pressure increases inside the breaker cylinder.

STEP 3.

The breaker rod has moved out of the cylinder and the tongue is pressing against the bead. As pressure increases, the tongue will break the bead of the tire from the rim.

STEP 4.

Depressing the RELEASE pedal of the pump causes a decrease in pressure in the clamping cylinder. With less pressure on the clamping cylinder side of the fluid return ball than on the breaker side, the fluid return ball is lifted off the seat and the breaker rod retracts. Retraction is due to an internal spring and pressure of the bead against the tongue. The breaker rod retracts first, followed by the clamping rod.

WARNING

The optional air/hydraulic pump is capable of generating fluid pressure up to 10,000 PSI. Keep both hands on the handles and away from the clamping jaw or breaker tongue. Make certain that the tool is properly aligned on the rim before allowing the bead breaking action. Do not continue to operate the air/hydraulic pump once the breaker rod is completely extended. Failure to comply with these instructions could result in personal injury or damage to the equipment.

1-2. OPERATION

Operation of the unit is as follows:

Make certain the tire is completely deflated.

Connect the hose of the a air/hydraulic pump to the hydraulic coupling on the Bead Breaker tool. Connect the air supply line to the air/hydraulic pump. Air supply should be 5-10 CFM at 100 PSI to obtain proper operating characteristics. In addition, the air line should be equipped with an air line filter.

Position the Bead Breaker so that the cup point set screw in the jaw makes solid contact with the rim and the teeth are positioned in the crevice between the bead of the tire and the rim.

NOTE

When a tire has a trash guard, you may have to drive two straight tire irons between the rim and the tire bead to get a starting point for the teeth.

Step on the PUMP end of the pump pedal. The clamping rod will begin to extend and the jaw will grip the rim.

CAUTION

Make certain that the teeth are slipping in between the rim and the bead. If not, depress the RELEASE end of the pump pedal and realign the tool. If the tool is not positioned correctly, extending the breaker rod may damage the tool.

Continue pumping until the tongue of the Bead Breaker pushes the bead free of the rim.

Depress the RELEASE end of the pump pedal.

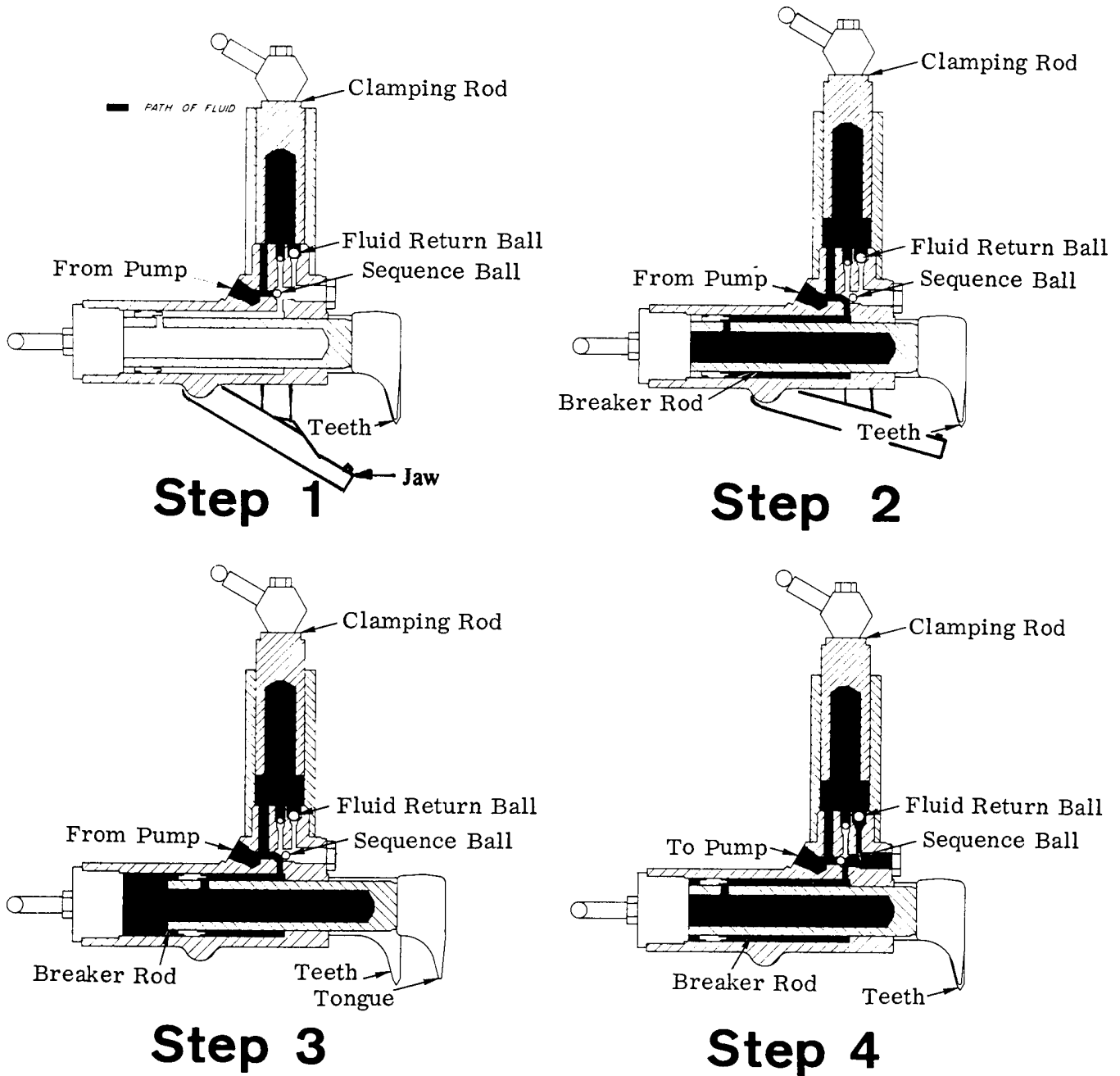

FIGURE A-1. SEQUENCE OF OPERATION

SECTION 2. SERVICE

2-1. GENERAL

Most malfunctions are a direct result of foreign matter - dirt, dust, water, etc. - entering the tool through the open hydraulic coupler union. Keep the union clean and capped when the pump is not connected to the tool. If your pump is to be used only with the Bead Breaker, it is recommended that the pump be permanently attached to the tool. This is accomplished by removing the quick-disconnect coupler union, the 45° elbow and the nipple, inserting a swivel and attaching the hose from the pump directly to the swivel. Use a pipe thread compound when assembling. This will eliminate the possibility of contamination through the open coupling.

The Bead Breaker is relatively easy to service. Some tools will be required for disassembly.

These are:

1. Spanner wrench
2. Common screwdriver
3. Needle-nosed pliers
4. Ice pick or sharp awl
5. Allen wrenches
6. Open end wrenches
7. Retaining ring pliers
8. Socket wrenches
9. Ratchet
10. Torque wrench

2-2. BEAD BREAKER

These instructions deal with the complete disassembly of the Bead Breaker. For information concerning the service of your pump, see the literature which accompanied it. If you are using the IMT-200 Air/Hydraulic Pump, see manual part number 99900120.

2-2-1. CLAMPING CYLINDER DISASSEMBLY

Before disassembling the Bead Breaker, the outside must be thoroughly cleaned to prevent contaminating the interior. Use warm, soapy water, rinse with clear water and wipe or blow the tool dry.

CAUTION

Proceed with disassembly in a warm, clean environment - one that is free of dust, dirt, grease, solvents, etc. and has a temperature of at least 70°F.

To disassemble the clamping cylinder, proceed as follows (refer to parts drawings):

Remove the four "E" retaining rings (19) that secure the clamping straps. Remove the straps.

Unscrew the bolt (1) at the top of the cylinder and remove the handle block (2).

Probe in the hole at the top of the clamping rod with a 5/32" Allen wrench (long leg in the hole). Unscrew and remove the socket head screw and washer (13 & 14).

Reinstall the bolt (1) and handle block (2) removed in a previous step. Pull the rod (18) out of the cylinder using the handle block.

Unscrew the cylinder (3) with the spanner wrench. Work the o-ring (5) and back-up washer (6) over the threaded portion of the body casting and remove them.

Grip the lip of the wiper (16) with the needle-nosed pliers and pull the wiper from the groove in the cylinder.

Puncture the u-cup (17) with an ice pick or sharp awl. Pry it out of the groove and push it on through the cylinder.

If it is necessary to remove the spring (7), grip it and turn it counterclockwise.

This completes disassembly.

2-2-2. CLAMPING CYLINDER ASSEMBLY

To assemble the clamping cylinder, proceed as follows:

NOTE

Use all of the seals supplied in the seal kit. It may avoid costly repairs in the future.

Thread the bottom spring anchor (4) on the slotted headless screw (9) and rotate the spring clockwise until it is tight.

Install the back-up washer and o-ring (5 & 6) over the threaded portion of the body casting.

CAUTION

Work the o-ring (5) and back-up washer (6) slowly into position. Avoid stretching them excessively.

Position the cylinder (3) with the wiper pocket up. Grasp the u-cup (17) with the needle-nosed pliers (Figure B-1) and insert it into the cylinder. Allow it to snap into place, helping with the fingers if necessary.

Install the wiper (16).

Lubricate the threads on the cylinder (3) and the body with STP® or equivalent. Screw the cylinder onto the body casting by hand. Get it as tight as possible. Torque the cylinder to 125 - 140 ft-lbs.

Slide the rod (18) carefully through the wiper (16) and u-cup (17) and over the spring (7) until it bottoms out. Insert the washer and socket head screw (13 & 14) into the hole in the top of the rod. With a 5/32" Allen wrench, turn the socket head set screw clockwise into the spring anchor. Torque to 90 - 110 in-lbs.

Position the handle block (2) over the hole at the top of the rod (18) and secure it with the bolt. Do not tighten the bolt (1).

Slide the clamping straps (20) over the jaw pin (21) and handle block pin and secure them with the four "E" retaining rings (19).

Tighten the sequence ball, spring, washer and cap (29,30,31 & 32). Torque to 25 - 40 ft-lbs.

Purge the system of air (refer to paragraph 3-2-5).

This completes cylinder assembly.

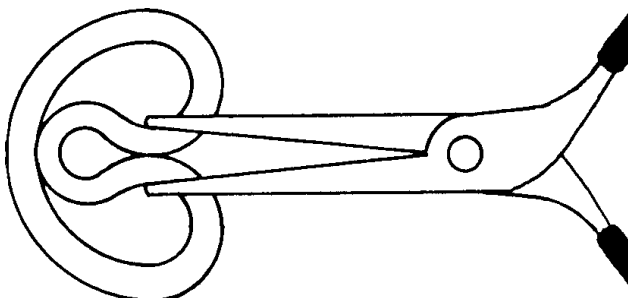

FIGURE B-1. U-CUP INSTALLATION

2-2-3. BREAKER CYLINDER DISASSEMBLY

Refer to parts drawings for location of parts. The cylinder is disassembled as follows:

Loosen the jam nut (33) on the "T" handle (34) and remove the handle.

Probe inside the hole in the head with a 5/32" Allen wrench and remove the socket head screw and washer (14 & 15).

Remove the head (38) with a spanner wrench.

Grip the tongue (27) and pull it forward. Drive out the spring pin (28) securing the tongue to the rod (39) and slide the tongue off the rod.

Push the rod back into the cylinder and pull it out the other end.

CAUTION

Do not attempt to remove the retaining rings or bearing from the rod. Special tools are required for this operation. Return the entire tool to the nearest service center if required.

Probe in the tongue end of the rod with a 5/32" Allen wrench and remove the socket head screw and washer (13 & 14).

Position the tool with the teeth up. Grip the lip of the wiper (46) with the needle-nosed pliers, and pull it out of the groove.

Puncture the u-cup (17) with an ice pick or sharp awl. Pry the u-cup from the groove and push it on through the cylinder.

Work the o-ring (36) and back-up washer (37) off the head.

Breaker cylinder disassembly is now complete.

2-2-4. BREAKER CYLINDER ASSEMBLY

Cylinder assembly is accomplished as follows:

NOTE

Use all of the seals supplied in the seal kit. It may avoid costly repairs in the future.

Hold the spring (35) inside the rod. Insert the socket head screw and washer (13 & 14) into the hole in the tongue end of the rod and torque to 90 - 110 in-lbs.

Position the cylinder with the teeth up. Grip the u-cup (17) with the needle-nosed pliers (Figure B-1) and insert it into the cylinder. Allow it to snap into place, helping with the fingers if necessary.

Install the wiper (44).

Insert the rod assembly (39) from the head end of the cylinder and slide it through the u-cup and wiper (17 & 44).

Slip the tongue (27) onto the rod (39) and fasten it in place with the spring pin (28).

Work the back-up washer and o-ring (36 & 37) onto the head.

CAUTION

When working the back-up washer and o-ring into position, do so slowly. Avoid stretching them excessively.

Lubricate the head (38) and cylinder threads with STP® or equivalent. Screw the head into the cylinder and torque to 175 - 225 ft-lbs.

Install the socket head screw and washer (14 & 15) and torque to 90 - 110 in-lbs.

Thread the "T" handle (34) into the head (38) until it bottoms out. Tighten the lock nut (33).

Purge the tool of air (refer to paragraph 3-2-5).

Assembly of the breaker cylinder is complete.

2-2-5. PURGING OF AIR

Note that these instructions are designed for use with the IMT 200 Air/Hydraulic Pump. If using a different pump, use this information as a guide only. Purging is accomplished as follows:

Connect the air/hydraulic pump to the tool.

Connect the pump to the air supply.

Position the pump so that it is higher than the tool and depress the PUMP end of the pedal.

After the clamping and breaker rods are fully extended, depress the RELEASE end of the pedal. Repeat this cycle (PUMP - RELEASE) about five times.

Extend both rods and keep them extended. Check for leaks. Make certain that the rods do not "creep" back into the cylinders.

2-3. CLEANING

Wash the exterior of the Bead Breaker with warm, soapy water. Rinse with clean water and blow the tool dry with an air nozzle. Also pay particular attention to the cleanliness of the pump.

CAUTION

Do not use solvent. Solvents may be corrosive to the seals and damage them.

2-4. STORAGE

Anytime the tool is put away, a number of checks must be made:

Completely retract both rods. An exposed rod may be subject to rusting, pitting and damage from striking other tools.

If chloride is spilled on the tool, rinse with clean water and blow dry.

Nicks and dents in the rod surfaces should be carefully dressed with fine grit emory paper. If left untended, they provide a starting point for rust.

NOTE

The chrome plated rod surfaces provide the seal for the tool. Any steps taken to ensure the continuing quality of the rod surfaces will increase the service life of the tool.

2-5. TROUBLESHOOTING

Figure B-2 lists problems, probable causes and solutions of the Bead Breaker and for convenience, the IMT 200 Air/Hydraulic Pump. See the parts drawings for reference.

SYMPTOM	PROBABLE CAUSE
RODS EXTEND TOO SLOWLY	Insufficient hydraulic pressure from pump 1. Check air supply (5 - 10 CFM @ 100 PSI) 2. Check clearance of inlet check ball. Ball must be flush with or below end of filter adapter.
RODS FAIL TO RETRACT	Hydraulic pump does not release 1. Dirt under pedal in release valve area - Clean pedal. Bearing is misaligned on breaker rod - Correct or replace. Broken or weak springs - Replace.
BOTH RODS EXTEND AT THE SAME TIME	Hydraulic pressure in breaker cylinder increases before clamping rod is fully extended. 1. Sequence ball not seated or broken or weak spring - Correct or Replace. 2. Loose screw and ball not seated - Correct or Replace.
BREAKER ROD RETRACTS AFTER CLAMPING ROD	Hydraulic pressure in breaker cylinder is not being released. 1. Fluid return ball did not reseat - Correct or Replace. 2. Dirt plugging return port - Clean. Weak or broken spring in breaker cylinder - Replace.
PUMP DOES NOT RECIPROCATE	Air piston stuck. 1. Check cylinder bore of pump for contamination or lack of lubrication. 2. Piston poppet not sealing - Replace.
PUMP RECIPROCATES. RAM WILL NOT EXTEND	Check prime. 1. Depress both air valve and hydraulic release valve at the same time.
PUMP EXTENDS RAM BUT WILL NOT HOLD SYSTEM PRESSURE	1. Outlet check ball not sealing properly - Correct or Replace. 2. Release valve mechanism not sealing properly. Check pin, ball, release poppet and poppet retainer - Correct or Replace.
PUMP EXTENDS RAM BUT WILL NOT BUILD TO MAXIMUM PRESSURE. NO VISIBLE SIGNS OF LEAKAGE	1. Check air supply (5 - 10 CFM @ 100 PSI). 2. Check for internal leakage. A. Release valve mechanism. B. Low relief valve setting. C. Inlet check ball not seating properly - Correct or Replace.
PUMP EXTENDS RAM BUT WILL NOT BUILD MAXIMUM PRESSURE. VISIBLE SIGN OF LEAKAGE THROUGH AIR EXHAUST MUFFLER.	1. Check piston sub-assembly. A. Replace copper gasket and assemble in vertical position. B. Replace piston packing.

FIGURE B-2. TROUBLESHOOTING CHART

SECTION 3. PARTS

3-1. GENERAL

This section contains the parts drawing and parts list for the IMT 210HP Bead Breaker.

3-2. ORDERING REPAIR PARTS

To order parts:

1. Give the model number.
2. Give the serial number located on the Bead Breaker.
3. Give the part number, description and quantity required.

Place your order with Iowa Mold Tooling Co., Inc., Box 189, Garner, IA 50438, telephone 641-923-3711, Fax 641-923-2424; or your nearest distributor.

ASSEMBLY REQUIREMENTS

(ITEM NUMBERS REFERENCED TO PARTS LIST)

- | ITEM | ASSEMBLY REQUIREMENT |
|------|--|
| 1. | TORQUE 30-40 FT-LBS. |
| 3. | TORQUE 125-140 FT-LBS. |
| 4. | LUBRICATE BEFORE ASSEMBLY. |
| 9. | TORQUE 40-50 IN-LBS,
APPLY LOCTITE® TO THREADS. |
| 13. | TORQUE 90-110 IN-LBS. |
| 15. | TORQUE 90-110 IN-LBS. |
| 22. | TORQUE 42-48 FT-LBS,
APPLY LOCTITE® TO THREADS. |
| 29. | TORQUE 25-40 FT-LBS. |
| 38. | TORQUE 175-225 FT-LBS. |
| 47. | TORQUE 80-90 FT-LBS. |

SEE FOLLOWING PAGE FOR DRAWING

ITEM PART NO.	DESCRIPTION	QTY
1. 72060066	CAP SCR 7/16-14X2 HH GR5	1
2. 7Y036949	STRAP PIVOT HANDLE	1
3. 70144173	CLAMP CYLINDER	1
4. 7Y201360	SPRING RETAINER	4
5. 7Q072220	O-RING (PART OF 50)	1REF
6. 7Q10P220	BACK-UP WASHER(PART OF 50)	1REF
7. 7Y201430	SPRING	1
8. 7Y017160	WASHER	1
9. 72060562	SET SCR 1/4-20X1 SH	1
10. 72066435	BALL 3/16 DIA SS	1
11. 76393561	DECAL -SER NO	1
12. 70144175	BODY	1
13. 72060708	CAP SCR 1/4-20X1-1/4 SH	2
14. 70024221	WASHER-COPPER (PART OF 50)	3REF
15. 72060907	CAP SCR 1/4-20X3-1/2 SH	1
16. 7R13P015	ROD WIPER (PART OF 50)	1REF
17. 7R535015	U-CUP (PART OF 50)	2REF
18. 70393569	CLAMP ROD	1
19. 72066560	RETAINING RING "E" 5/8	4
20. 70144172	STRAP	2
21. 7Y205288	PIN	1
22. 72060753	CAP SCR 3/8-16X1 SH	2
23. 7Y204238	SPACER	2
24. 70144174	JAW	1
25. 72060985	SET SCR 3/8-16X1/2 SHCUPPT	1

ITEM PART NO.	DESCRIPTION	QTY
26. 72060983	SET SCR 3/8-16X3/8 SHCONEPT	1
27. 7Y036853	CLAW	1
28. 72066319	ROLL PIN 3/8X2-1/4	1
29. 7Y021599	VALVE SPRING CAP	1
30. 70024222	WASHER-COPPER(PART OF 50)	1REF
31. 7Y016724	SPRING	1
32. 72066437	BALL 1/4 DIA SS	2REF
33. 72062024	NUT 1/2-13 HEX JAM	1
34. 7Y202636	HANDLE	1
35. 7Y202625	SPRING	1
36. 7Q072224	O-RING (PART OF 50)	1REF
37. 7Q10P224	BACK-UP WASHER(PART OF 50)	1REF
38. 72533288	BREAKER CYLINDER HEAD	1
39. 70393570	BREAKER ROD	1
40. 7Y204237	RETAINING RING	1
41. 7Y204236	BEARING	1
42. 7Y201433	RETAINING RING	1
43. 72533286	REDUCING NIPPLE	1
44. 76393572	ROD WIPER (PART OF 50)	1REF
45. 72533616	STREET ELBOW 45°	1
46. 70143089	TOOTH	2
47. 72060794	CAP SCR 1/2-13X1-1/4 SH	4
49. 72533287	COUPLER - QUICK DISC F	1
50. 94393571	SEAL KIT (INCL:5,6,14,16,30,36,37,44)	1

FIGURE C-1. BEAD BREAKER - 210HP (79075107)

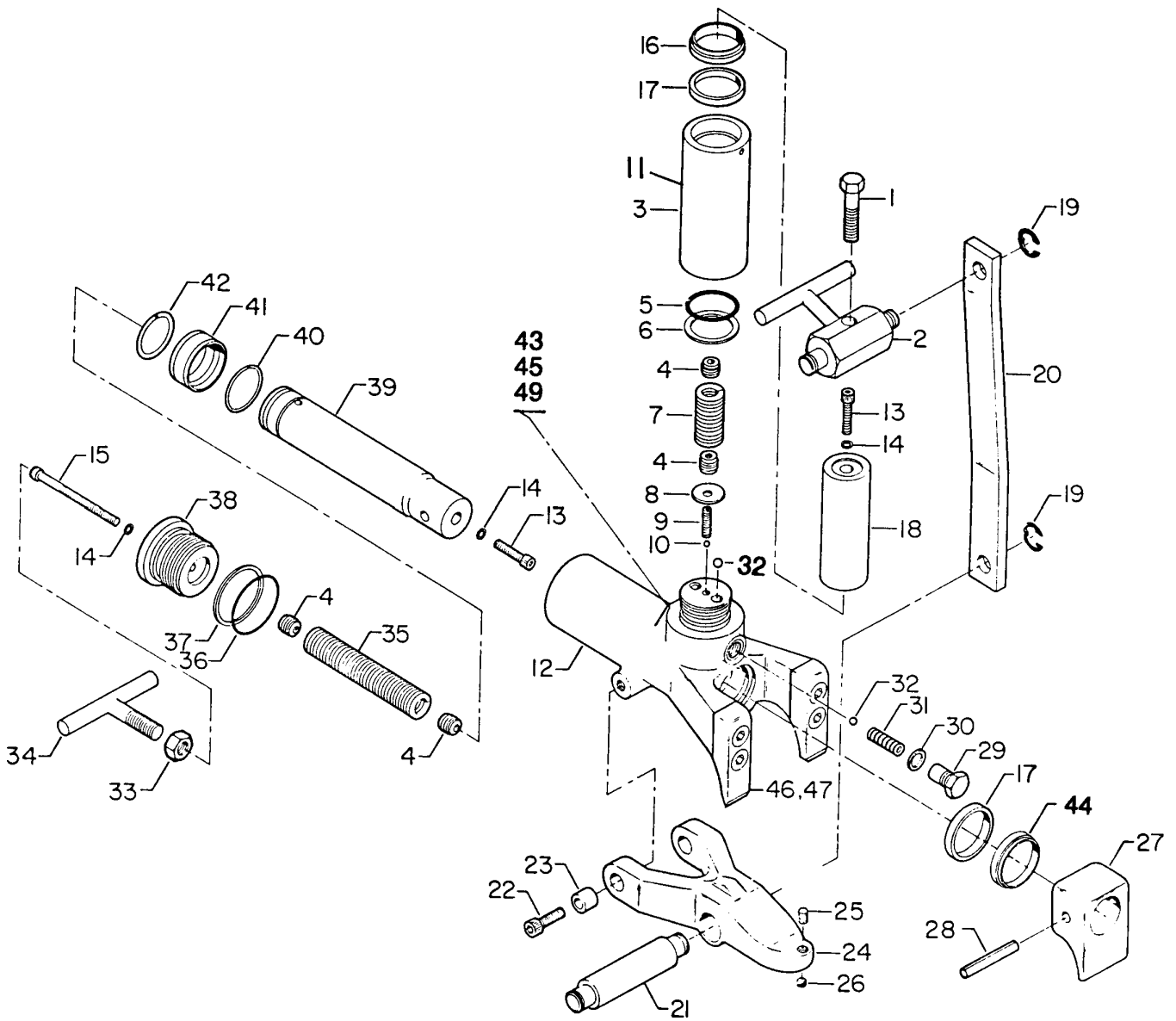

FIGURE C-1A. BEAD BREAKER - 210HP (79075107)

SECTION 4. OIL SPECIFICATIONS

4-1. OIL SELECTION

Minimum viscosity specifications for hydraulic oil to be used in the IMT 210 HP system are given in Figure D-1. Any major oil company can supply products which meet these requirements.

Oils selected by the user for this class of equipment, in addition to meeting viscosity requirements, should have the following additives:

1. Antifoam inhibitors
2. Antioxidant inhibitors
3. Rust resistant additives
4. Antiwear additives

4-2. OIL SPECIFICATIONS

Figure E-1 provides oil specifications for a full range of operating temperatures encountered in the temperate zones. Arctic conditions present special requirements which are not within the scope of the table and must be given special consideration and individual analysis. Consult your local oil supplier for the proper fluid for working under these severe conditions.

4-3. CONTAMINATION AND TESTING

Contamination of the hydraulic oil by solvents, water, dust or other abrasives will result in a premature breakdown of the oil's antifoam, lubrication, anti-rust and viscosity properties. Prolonged exposure to water or high temperatures (above 180°F) will cause an increase in the oxidation rate, producing varnish forming materials and sludge in the oil.

Periodically a sample of the hydraulic oil in the system should be drawn off and its condition checked for breakdown. To check oil quality:

1. Place oil sample in a clean glass.
2. Smell oil to detect a burnt or rancid odor.
3. Examine the oil for a cloudy or dark color.
4. Allow the sample to stand for several minutes and inspect it for water which will settle to the bottom. Water can result from a leak in the system or condensation due to temperature extremes.

When any of these conditions is observed, the system should be purged and filled with new oil.

AMBIENT TEMPERATURE RANGE	0 - 90°F	BELOW 32°F	32 - 90°F	ABOVE 90°F
MIN. POUR POINT, °F	-30	-25+	+10	+10
MAX. VISCOSITY, SSU @ 0°F	4000	4000	-----	-----
MIN. VISCOSITY, SSU @ 100°F	140 - 195	100 - 130	150 - 200	200 - 315
MIN. VISCOSITY, SSU @ 210°F	48	41 - 43	43	47
MIN. VISCOSITY INDEX	139	90	90	90

FIGURE D-1. HYDRAULIC OIL SPECIFICATIONS

