

22 AUTOSOCKS — AVAILABLE FOR CARS AND TRUCKS!

Frequently Asked Questions

Q1 How do they work?

A1 Basically, it's to do with friction. Dry snow and ice sticks to fabric, especially 'woolly' fabric as those of us who remember snowballing in woolen mittens will remember. AutoSock are made from a hairy fabric which sticks to the snow. The fibers, which become hairier with use, are arranged at right angles to the direction of travel to optimize grip. Very importantly, the specially developed textile also "wicks away" any water that's found between the ground and the tire (generated e.g. by the warmth of the sun or wheel spin) thereby maximizing the friction grip.

Q2 How well do they work?

A2 Astonishingly well! They are more effective than winter tires (and a lot cheaper) and are also more effective than snow chains in certain situations, especially on ice. They have been tested and formally approved in Europe by Audi, Citroen, Mercedes-Benz, Peugeot, Volkswagen, and BMW and in Japan by Toyota, Honda, and Volvo truck of Sweden. They are also approved by several European road transport research institutes and the German TÜV. A range of test data is available at www.autosock.com.

Q3 What sort of conditions can I use them in?

A3 They'll improve traction on any snow or ice—even in soft, deep snow or in wet snow. It's recommended that you take them off when you get back to tarmac, although the reality is that they probably will be driven on tarmac during those intermittent tarmac/snow/tarmac/snow conditions experienced before leaving the snow for good. (The TÜV test included 50 kilometers at 50kph on dry tarmac. AutoSock passed this "misuse test" but of course tarmac driving is not recommended as it increases wear.)

Q4 What's it like driving with AutoSock?

A4 Silent and smooth as you'd expect. There's none of the loud rattling and bumpy ride associated with snow chains. Because there's no danger of damage to the vehicle structure, they are approved for speeds up to 30mph/50kph; this is faster than is recommended for snow chains, although your speed should of course be appropriate to the weather and road conditions.

Q5 Is there anything else I should know about?

A5 Nothing to be concerned about although certain users may wish to note that

You can use them with your vehicle's electronic aids left on unlike snow chains which should NOT be used with traction control and anti skid devices (e.g. ESP/ ASC+T/ ASR/ ABS).

They are breathable so there's no adverse effect on brake cooling.

It's recommended that users of rear wheel drive cars should also fit a set to the front wheels to provide better directional stability, especially under braking.

Q6 If my car has limited space between the wheel and the mechanical parts can I use AutoSock?

A6 Yes, AutoSock works even with vehicles which have low clearance between the tire and the body and between the tire and the suspension.

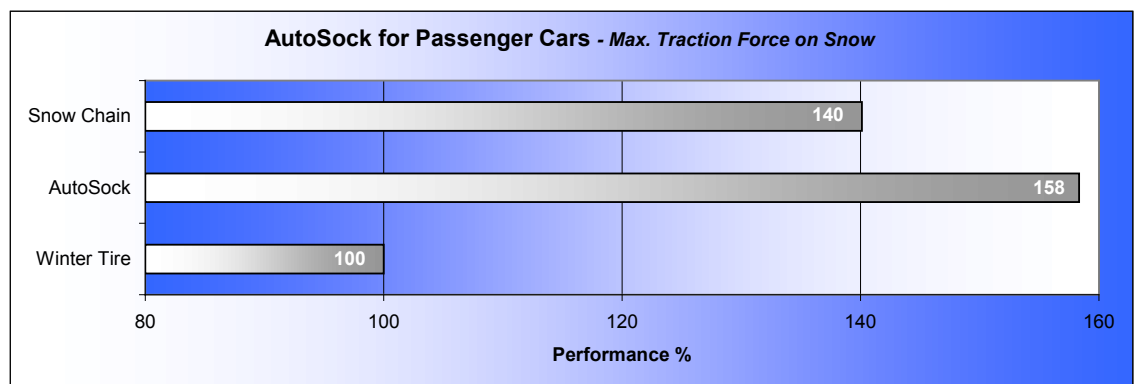

DATE: Dec 06 2007	AIR TEMP.: -7°C/25°F	TIRE SIZE: 205/55 R16	INFLATION FA: 3.0 bar	TEST VEHICLE: Pontiac FWD
LOCATION: Loveland Pass	CONDIT.: Dry snow, cloudy	ABS: on	INFLATION RA: 3.0 bar	TEST SURFACE: Packed Snow

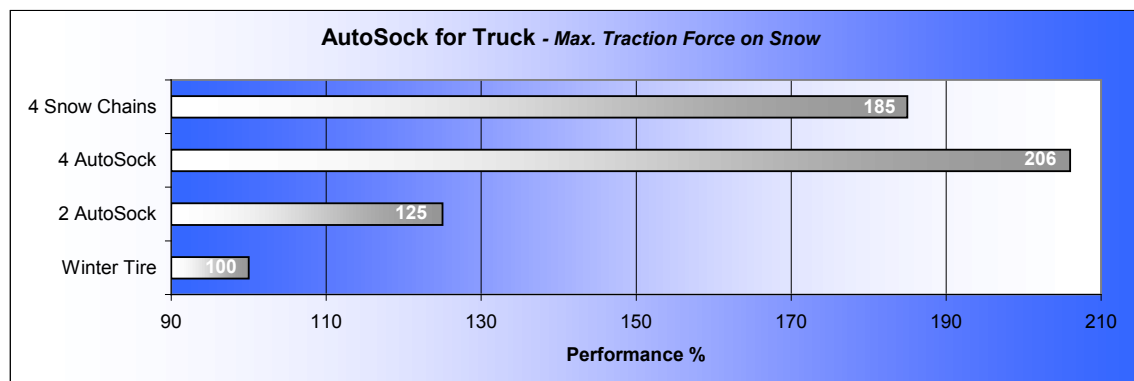

DATE: Dec 06 2007	AIR TEMP.: -7°C/25°F	TIRE SIZE: 295/70 R22.5	INFLATION FA: 8.0 bar	TEST VEHICLE: Peterbilt
LOCATION: Loveland Pass	CONDIT.: Dry snow, cloudy	ABS: on	INFLATION RA: 8.0 bar	TEST SURFACE: Packed Snow

Test performed to European önorm standards.

Truck AutoSock now approved as an alternative traction device to tire chains by CDOT*.

*(Visit CDOT website for details.)

AutoSock — Skidding? Stop. Think Autosock! AutoSock on! Drive!

*AutoSock
... brings you home!*



Approved by Colorado DOT for Trucks!

AutoSock is the high tech solution to an age old problem—how to give road tires the grip they need on ice and snow to...get you home!

AutoSock—textile wheel covers with an elasticated edge: you just slip them over the driving wheels when you find yourself getting stuck. (“Yes—it really is this easy” and “Yes, of course they work!”) Be prepared for the winter by carrying a set of AutoSock in your car, happy in the knowledge that

- Fitting them is easy. If you can pull a sock over your foot you can push a fabric cover over a wheel
- Fitting requires no practice.
- They weigh less than 1kg and take up minimal space.
- It’s sensible to keep them with the spare wheel, always ready for use
- They’re reusable again and again—providing value for money for years to come.
- They work!

Probably the most difficult part of the operation is remembering that they’re there!



AutoSock provides an ideal “Get me Home” or “Get me to that meeting” solution-but only if you keep a set in the car! Although developed in Norway, they’re particularly appropriate for the U.S. where we experience sudden and sporadic snow-fall, usually short lasting but so often the cause of massive disruption and inconvenience while it lasts.

Most of us take our chances because, all things considered, it’s hard to justify the use of winter tires and carrying snow chains is “over the top”.

Any unsalted roads near home which you need to use? Getting down to the main road? And back again?



Each set includes:



- One pair of AutoSock
- Long gloves
- User instructions
- Storage bag

*Showroom
displays available
for truck or auto.*

Call Today!

800-525-8888

**More information at
www.autosock.us**

Fitting:

It could hardly be simpler. Stop the vehicle and apply the handbrake. Fit AutoSock to the driving wheels of the car, starting at the top of the tire and working downwards. Move the vehicle approximately 1 yard and put the remainder of each ‘Sock’ into position. The AutoSock will automatically self-center when you start driving.

Use:

There’s NO need to turn off any electronic traction and stability devices, e.g. ETS, ASR, ESP, DSC. Drive off gently, avoid wheel spin. Extreme acceleration and braking could damage the product.

Removal:

Take AutoSock off the wheels, shake off any snow, and put them back in their storage pouch pending washing or further use.

Now approved in Washington as a chain alternative for cars!

GARAGE EXHAUST HOSES & VEHICLE PROTECTION

Tailpipe Adapters



- Crushproof offers a complete line of accessory items
- Parts depicted below are the result of years of accumulated customer input, Crushproof's technology and extensive field testing

Ascot No.	Mfg. No.	Adapter Description	Tailpipe Style	Tailpipe Size	Hose I.D.	Price
391-93000	TPA3000	Split Adapter	Separated	Up To	3" 2-1/2"	\$75.42
391-90250	F250	Straight w/ Hook & Chain	Single	Up To 2"	2-1/2", 3", 3-1/2"	\$17.72
391-90300	F300	Straight w/ Hook & Chain	Single	Up To 2-1/2"	2-1/2", 3", 3-1/2"	\$23.99
391-90400	F400	Straight w/ Hook & Chain	Single	Up To 3-1/2"	3-1/2", 4", 5"	\$48.44
391-91250	RA250	Bell w/Snaps	All	All	3"	\$29.05
391-91300	RA300	Bell w/Snaps	All	All	3"	\$29.05

Crushproof Exhaust Ventilation System

Door Ports



Y-Connectors



Ascot No.	Mfg. No.	Description	Price
391-00125	DF25	2-1/2" Rubber Door Port	\$22.19
391-00130	ADF30	3" Aluminum Door Port	\$31.58
391-00140	ADF40	4" Aluminum Door Port	\$42.41
391-00225	RY25	2-1/2" Rubber Y-Connector	\$25.56
391-00230	RY30	3" Rubber Y-Connector	\$25.85
391-00240	AY40	4" Aluminum Y-Connector	\$68.86

Flarelock Exhaust Hose!

Flared end permits connecting hoses!



- FLT250 - 11 ft x 2.5 in. **\$79.75**
- FLT300 - 11 ft x 3 in. **\$96.36**
- FLT400 - 11 ft x 4 in. **\$149.95**

Call 1-800-525-8888
Additional Items Available

TIRE BAGS, SEAT PROTECTORS, STEERING WHEEL COVERS, PAPER FLOOR MATS, PARTS BAGS

Dispensing Racks

Centralize your cleanliness products for the professional image your business needs and the convenience your employees deserve. The top tray holds paper floor mats and elastic band steering wheel covers. Rollers are for seat covers, tire bags, and parts bags.

Order No.	Description	Ship Wt. Lbs.	Price
PSC	Seal Protectors - Roll of 500	20	\$65.90
SWC	Car Steering Wheel Covers - 500 pkg	10	\$62.25
STB	Standard Tire Bag - Roll of 250	25	\$59.95
HDTB	Large Tire Bag for SUV - Roll of 250	30	\$82.95
FPFM	Heavy Duty Paper Floor Mat - Box of 500	50	\$39.95
WPB	Parts Bags, 12" x 20" - Roll of 500	15	\$44.15
DR	Dispenser Stand Only	25	\$194.40
41110	Large Tire Bag - Roll of 100		\$29.95



#WPB



#PSC



#SWC



#STB & #HTB & 41-110



#FPFM

UGIGRIP TIRE STUDS & OKU STUDDING EQUIPMENT 25

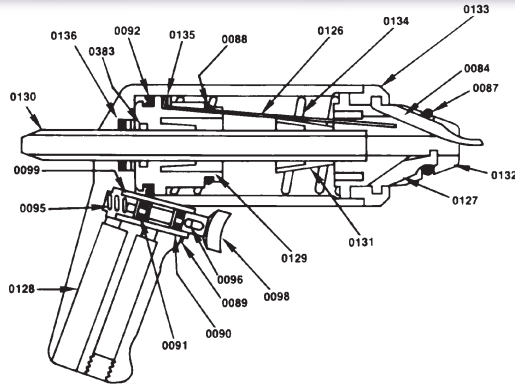

MODEL AS-9 GUN Parts Breakdown

Part No.	Description	Part No.	Description
0084	External Finger	0127	Internal Finger
0087	"O" Ring	0128	Handle body
0088	"O" Ring	0129	Piston
0089	"O" Ring	0130	Feed Tube
0090	"O" Ring	0131	Tapered Sleeve
0091	"O" Ring	0132	Head (Steel)
0092	Piston cup	0133	Ring Nut
0095	Trigger Spring	0134	Compression Spring
0096	Trigger Pin	0135	Ring
0098	Trigger	0136	"O" Ring
0099	Trigger Sleeve	0383	Piston Cup
0126	Pressing Spring		

Studding Equipment

Ascot No.	Studding Guns	Use with studs numbered
458-00010	10G	TSMI-11-12-13-15-16-17
458-00011	10T	TSMI-19-21

Steel lightweight studs available in all sizes. Lightweight reduces road wear. Steel 12SL, 13SL, & 16SL meet requirements for Washington, Oregon, and Idaho.

Stud Gun Repair and Conversion Kits

Ascot No.	Mfg. No.	Description
458-03810	0381	Tire Stud Gun Mini Repair Kit Includes (3) 0084 External Fingers; (1) 0087 O-Ring; (1) 0088 O-Ring (3) 0126 Pressing Springs
458-03820	0382	Tire Stud Gun Large Repair Kit Includes (6) 0126 Pressing Springs; (3) 0084 External Fingers; (2) 0087 O-Rings; (2) 0088 O-Rings; (1) 0092 Piston Cup; (1) 0136 O-Ring
458-00911	00911	AS-9 to AS-11 Conversion Kit Converts AS-9 Gun to AS-11 Truck model. Includes (1) 0401 Truck Feed Tube; (1) 0400 Truck Stud Gun Head; (3) 0127 Truck Stud Gun Internal Fingers.

Studding Equipment

Ascot No.	Mfg #	Description
458-00010	10G	Stud Gun. Standard of the industry. Automatic, lightweight
458-00002	KFP2	Stud Feeder Fully automatic with 110 Volt motor, fast loading. Provides positive stud orientation. Feeds up to 225 studs per minute.
458-04048	4048	Feederboy Stud Gun. Designed for fast feeding studs of AS-9 Gun. Attaches with screw clamp. Operates by manually turning the feeder cap.
458-00500	K500	Studding Equipment Kit. Consists of K-5 stand, AS-9 Gun, KFP2 Automatic Stud Feeder.
458-00005	K5	Stud Feeder. Includes shield for gun. Welded steel construction with saddle.

Complete OKU

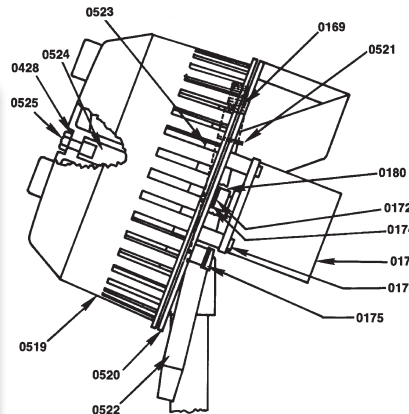

MODEL KFP2 Parts Breakdown	
Part No.	Part name
0169	Deflector Spring
0172	Snap Ring
0173	Screw
0174	Washer
0175	Clamp
0177	Motor
0180	Drive Shaft Pin
0428	Washer
0519	Feed Wheel
0520	Base Plate
0521	Retaining Ring
0522	Feed Tube
0523	Screw
0524	Shaft
0525	Hex Bolt

Ugigrip®, Self-Adjusting Carbide Tire Stud

- Delivers full-time traction, increases safety, convenience and security
- To order studs to best fit your customers' tire, use the TSMI number recommended by the tire manufacturer.



Single Flange Studs

TSMI SIZE	11	12	13	15	16	17	19
Overall length	.345	.375	.470	.520	.585	.615	.635
Jacket Diameter	.197	.197	.197	.197	.197	.197	.250
Bottom Diameter	.354	.354	.354	.354	.354	.354	.435
Nearest 32 nd to hole depth	11/32"	12/32"	13/32"	15/32"	16/32"	17/32"	19/32"

Call For Prices! 1-800-525-8888

Denver • Salt Lake City • Dallas • Albuquerque

TIRE CHAINS

Largest Stock of tire chains in the Rocky Mountain Area!

Laclede™ Tire Chains

TIRE SIZES				Stock Number	
Single mount		Dual Mount			
8.25-15LT	P265/75R16	255/60R17	245/70R17.5	3210R	
10-15LT	245/85R16LT	P255/70R17	P255/70R18		
265/70R15LT	265/70R16LT	P265/65R17	275/55R18		
265/75R15LT	265/75R16LT	P265/70R17	P275/60R18		
305/50R15	265/80R16LT	265/70R17LT	225/70R19.5		
31X10.50-15LT	275/70R16LT	275/65R17	245/70R19.5		
33X10.50-15	295/50R16LT	235/75R17.5			
P265/70R16	245/75R17LT				
PR78-15	PR78-16	34X9-16	285/65R18LT		3227R
11-15LT	12-16.5LT	31X10.50-16.5LT	285/45R19		
31X11.50-15LT	P285/60R16	285/60R17	275/60R20		
32X11.50-15LT	275/65R16LT	285/70R17	P285/50R20		
33X9.50-15LT	285/60R16LT	305/45R17			
33X13.50-15	32X11.50-16LT	P265/60R18			
34X9.50-15LT	33X13.50-16	285/60R18			
285/75R16LT	265/70R18	275/70R18LT		3228R	
31X12.50-16	275/65R18				
12-15LT	11L16	33X12.5-16.5	33X13-18	3229R	
P315/70R15	285/70R16LT	33X15.5-16.5	275/65R20LT		
325/60R15	295/75R16LT	275/70R17	305/50R20		
31X13.5-15	305/70R16LT	285/75R17LT	305/55R20		
32X12.50-15	305/85R16LT	295/70R17LT	285/50R22		
33X12.50R15	315/75R16LT	305/70R17	33X11.5-22		
33X14-15	35X12.5-16	33X12.50-17	285/55R20LT		
33X14.50-15	35X13.5-16	10.50/80R18	32X11.50-20		
35X12.50-15	36X13-16	285/75R18LT			
35X14.5-15	32X12.50-16.5LT	325/60R18			
QR78-15	38X13-16	345/55R17	325/65R18		3231R
35X13.5-15	35X12.50-16.5	35X12.50-17	325/60R20		
37X13-15	38X12.50-16.5	37X12.50-17	35X12.50-20		
345/55R16LT	315/70R17LT	305/60R18	325/50R22LT		
37X12.50-16	325/70R17	305/70R18LT	35X12.5-22		
35X14-15	35X14-16	37X12.5-16.5	37X13.5-17	3235R	
36X12.50-15	36X12.5-16.5	38X15.5-16.5	14-17.5		
37X13.50-15	36X14-16.5	355/70R17LT	285/70R19.5		
35X15-15	35X16-15	38.5X14.5-15	365/65R16	7.00-15TR 7-17.5	3237R
35X15.5-15	36X14.5-15	38.5X15-15		6.50-16LT	
37x14.50-15	38x14.50-16	40X17-16.5	37x13.50-22	7.50-15LT 7.00-16LT	3251R
39.5X15-15	325/80R16	355/65R18		7.50-15TR 7.00-17	
40X17-15	39.5X15-16.5	37x13.50-20			
355/80R20	13-22.5	15-22.5	385/65R22.5		3255R
42X15-16.5	38X13.5-20	335/80R-18		7.00-18 6.50-20	3259R
355/60R20				8-19.5 7-22.5	
18-22.5	445/65R22.5				3261R
38.5X16-15	39.5X15-16	39.5X18-16.5	15-19.5	7.50-17	3265R
39.5X18-15	38.5X16-16	38X15.5-18	38X15.50-20	7.00-20	
445/50R22.5	455/55R22.5				3269R
445/65R19.5	16.5-22.5	425/65R22.5			3271R



Wide Base Truck Cam Chains

Dual Truck Chains

DUO Tractor Chains

Tire Sizes					Stock No.
9.5-24	9.5-28	11.2-24			DUO214
9.5-32	11.2-28	230/95R32	355/80R20		DUO226
10.5/80-18	12-16.5	280/70R20	300/70R20	315/75D15	DUO225
12.4-24					DUO229
9.5-36	9.5-38	11.2-32	12.4-28		DUO218
11.2-38	11.2-44	12.4-36	12.4-38	270/95R44	DUO232
13.9-36	320/85R34				DUO242
13.6-24	13.6-26	14.9-24			DUO240
14.9-26					DUO250
14.9-28	14.9-30				DUO252
13.6-28	16.9-24	320/85R38	340/85R28	380/85R34	DUO260
14.9-38	15.5-38	320/90R46			DUO254
17.5-24	17.5L-24				DUO263
16.9-26	16.9-28	420/85R28			DUO262
16.9-32					DUO266
16.9-34	230/95R44				DUO270
18.4-16.1	21.5L-16.1				DUO264
18.4-24	19.5L-24				DUO268
16.9-30	18.4-26	18.4-28	18.4-30	540/65R30	
550/65R25	600/65R28				DUO271
18.4-34	480/85R34	600/65R25			DUO273
16.9-38	18.4-38	20.8-34	380/90R50	420/80R46	
460/85R34	480/80R38				DUO272
18.4-42	18.4-46	380/90R54	480/80R46		DUO277
21L-24					DUO275
20.8-38					DUO276
24.5-32	23.1-34	28.1-34	620/70R42	650/75R32	DUO282

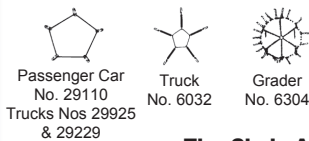

Tire Chain Adjusters

Ascot No.	Mfg. No.	Description	Qty.
458-29110	29110	Passenger Car - Rubber	2 per bag
458-29225	29225	Light Truck - Rubber	2 per bag
458-29229	29229	Heavy Truck - Rubber	2 per bag
458-06302	6302	Light Truck - Spring	1 pair per container
458-06304	6304	Tractor/Grader - Spring	1 pair per container

LG Cam Series Available



Tire Sizes			Tire Chain Stock No.
13.00-24/25	14.00-20/21	15.5-25	2612
14.00-24	14.00-25		2615
16.00-20/21	17.5-25		2624
16.00-24	16.00-25		2627
20.5-25			2633
18.00-25	18.00-24	18.00-26	2636
18.00-33			2642
23.5-25			2645
26.5-25	755/70R25	30.5R32	2657
710/70R38		800/65R32	

Laclede Single Truck Chains

- Recommended for highway use
- Available in R—regular side chain
- Available with cam side chain



Laclede Alpine Premier Chains

- Diamond pattern design provides superior traction
- Installed without lifting or moving vehicle
- Recommended for class “S” cars and ABS systems
- Recommended for front wheel drive



Tire Sizes					Non-Cam Stock No.
7.00-14LT	P205/75R14	205/60R17.5			
185-14	195/75R14LT	28X8.50-14			2209R
H70-14ST		LR78-15	7.00-15LT	195/75R15LT	
H78-14ST	H78-15ST	6.70-15LT	P215/75R15	7-17.5LT	2211R
9-14.5MH	P235/75R15	8.00-16.5	225/75R16LT	235/65R17	
215/75R14LT	215/75R15LT	P225/70R16	255/75R16LT		2216R
H78-15LT	30x9.50-15	P225/75R16	P235/60R17		
P225/75R15	6.50-16LT	205R16	P235/65R17		
7.00-15TR	245/75R15LT	235/75R16LT	8-17.5	225/65R18	
7.50-15LT	7.00-16LT	245/70R16LT	8.50-17.5	235/60R18	
P275/60R15	8.75-16.5	255/65R16LT	215/70R17.5	235/65R18	2219R
235/75R15LT	215/80R16LT	8.75-16LT	P235/50R18	245/55R19	
245/70R15LT	215/85R16LT	P235/70R17	P255/45R18		
NR78-15	LR78-16	235/85R16LT			
7.50-15TR	7.50-16LT	7.00-17LT			2221R
275/60R15LT	9.50-16.5	215/75R17.5			
7.50-17	245/70R17LT	225/70R17.5	7.00-18	8-19.5	2214R
P245/65R15	P245/75R16	265/60R16LT	P245/55R17	275/60R17	
P245/70R15	P255/65R16	275/60R16LT	P245/65R17	P255/55R18	
P255/70R15	P255/70R16	30X9.50-16LT	245/65R17	255/55R18	
P265/70R15	P275/60R16	31X11.50-16	P245/70R17	255/60R18	2229R
P265/75R15	235/70R16LT	32X9-16LT	P255/55R17	235/55R19	
255/75R15LT	235/80R16	32X10.00-16LT	P255/60R17		
29X9.50-15	245/75R16LT	10-16.5LT	P255/65R17		
P235/70R16	255/70R16LT	225/75R17LT	P275/60R17		
P245/70R16	265/50R16LT	P235/75R17			
8.25-15TR	255/85R16LT		P275/60R20		
P275/70R16		275/55R20	245/70 19.5		2228R
7.50-18	265/70R19.5	6.50-20	7.00-20		2233R
9.00-15TR	9R17.5		8-22.5	255/70R22.5	
9.00-16LT	10R17.5	7.50-20	235/80R22.5		2237R
10-15TR	8.25-20	245/75R22.5	275/70R22.5		
11R17.5	9-22.5		QR78-16		2239R
9.00-20	10-22.5	255/80R22.5	265/75R22.5		2241R
10.00-20	11-22.5	275/80R22.5			2245R
295/75R22.5	305/70R22.5	285/75R24.5	275/80R24.5		2247R
10.00-22	11-24.5				2249R
11.00-15TR	11.00-20	12-22.5	12.5-22.5	295/80R22.5	2251R
12.00-20	13/80R20	11.00-22	315/80R22.5	12-24.5	2255R
13.00-20	14/80R20	365/80R20	12.00-24		2257R
14.00-24					2273R

TIRE SIZES				STOCK NO.
12" & 13" RIMS	14" RIMS	15" RIMS	16" & OTHER RIMS	
145R12 P145/80R12	155R12 P165/70R12			1505
145R13 P145/80R13 P155/70R13	P165/65R13 P165/70R13			1510
155R13 P155/80R13	175/60R13 P185/60R13	165/65R14 P175/60R14	135R15	1515
165R13 P165/80R13	P175/70R13 P195/60R13	165/70R14 P175/65R14	145R15	1520
175R13 P175/75R13 P175/80R13 P185/70R13 P195/70R13	P205/60R13 P165/75R14 P175/70R14 P175/75R14	185/65R14 P195/60R14 P195/65R14 205/55R14	155R15 P185/55R15 P195/50R15 P195/55R15	1525
185R13 P185/80R13 P205/70R13	175R14 P185/70R14 P185/75R14 P195/70R14	P205/60R14 P215/60R14 185 6014	165R15 P165/80R15 P175/70R15 P205/50R15 P205/55R15	1530
	185R14	P195/75R14	175R15 P185/70R15 195/65R15	P190/65R390 1535
	195R14 P205/70R14 P205/75R14 P215/65R14	P215/70R14 P225/60R14 P255/60R14 P255/70R14	185R15 P195/70R15 P205/60R15 P205/65R15	P205/55R16 P205/60R16 P205/50R17 1540
	205R14 215R14 P215/75R14	P225/70R14 P235/60R14 27X8.50-14LT	P195/75R15 P205/70R15 P205/75R15 P225/60R15	P205/65R16 P215/55R16 P215/60R16 P215/70R17 1545
	P225/75R14 P245/60R14		P265/50R15	P205R16 P215/55R17 1547
		205R15 P215/70R15	P215/75R15 P235/60R15	P215/65R16 P215/70R16 P225/55R16 8.00-16.5 P225/50R17 1550
		P225/70R15 P225/75R15 P245/60R15		235/60R16 P245/55R16 225/60R17 6.50-16LT 215/60R17 P215/65R17 215/55/18 1553
		P255/60R15		P225/55R17 225/60R17 P235/55R17 225/50R18 215/55/18 1555
		P235/65R15 P235/70R15 P275/50R15		215/75R16 235/65R16 P255/50R16 P235/60R17 225/55R18 225/60R18 235/55R18 1555



McGEE COMPANY

Denver (HDQTR)
1140 South Jason St.
Denver, CO 80223
(800) 525-8888
(303) 777-2615
FAX (303) 777-7140

Salt Lake City
1101 S. 700 West
Salt Lake City, UT 84104
(800) 525-8888
(801) 487-8751
FAX (801) 487-8753

Albuquerque
4412 Prospect NE
Albuquerque, NM 87110
(800) 525-8888
(505) 883-9613
FAX (505) 883-1382

Dallas
8504 Chancellor Row
Dallas, TX 75427
(800) 525-8888
(214) 689-0400
FAX (214) 689-0448

BRAKE LATHES

The best selling brake lathe in the **WORLD**

Ammco 4000SP Brake Lathe

- Cuts rotors in one pass with positive rake tool-bits
- Accurate, durable and easy to use
- Legendary AMMCO quality and durability

4000B-SP is pictured with optional toolbox, tool-board and "E" adapter kit.

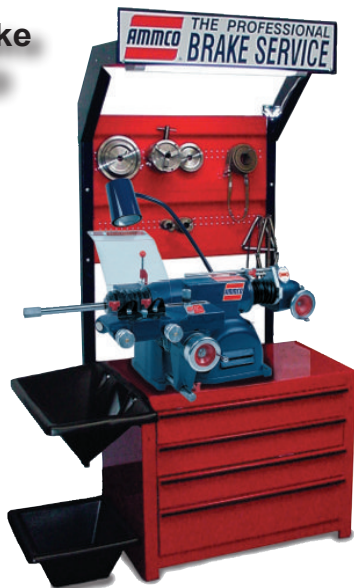

MORE EFFICIENT THAN EVER

BITS — AMMCO, HUNTER, KWIK-WAY, ACCUTURN

Silencers



6921



6922



6930AM

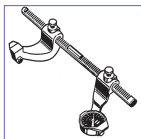

8500

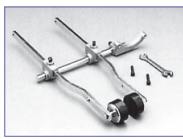

7075

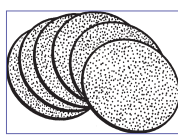

8756



9183



9800

Ascot No.	Part No.	Description	Sale Price
418-40410	940410	Carbide Insert, Pos. Rake, for FMC1 Lathes, 10pk.	\$39.95
418-40415	940415	Carbide Insert, Pos. Rake, for KWIK-WAY2 Lathes, 10pk.	\$46.62
418-40420	940420	Carbide Insert, Neg. Rake, for HUNTER3 Lathes, 10pk.	\$23.32
418-40430	940430	Carbide Insert, Neg. Rake, for PERFORMANCE4 Lathes, 10pk.	\$25.11
418-40435	940435	Carbide Insert, Pos. Rake, for ACCUTURN5 Lathes, 10pk.	\$49.95
418-16263	2216263	Carbide Insert for Hunter OCL 360 on the car lathe, 10pk.	\$59.25
418-06914	691410	Carbide Insert, Negative Rake AMMCO lathes, 10pk., 1000, 2002, 3000, 4000, 4100, 7000, 7700	\$19.79
418-69186	69186	Carbide Insert, Positive Rake, AMMCO 3850 Lathe, 6pk.	\$34.95
418-06910	06910	Carbide Insert for Pro Cut 610 On-The-Car Lathe, 10pk.	\$69.23

Package special 4000SP, 2500 AM bench, & 900006 Adapter Set E - **\$6595.00**
Limited Quantities!

Popular Specialty Adapters

95000010 for 2004 and newer Ford F150 rotors with a pressed bearing
\$295.95

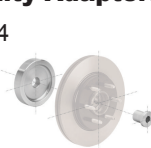

940928 for late model GM and Chrysler 3/4 & 1 ton 4x4 truck rotors with a pressed bearing
\$249.95



6936 Cross Feed extension, extends diameter reach up to 4 1/2" **\$231.33**



41270 Chuck for Hubless 5.28"-10.2"



9234 for large hub mount applications

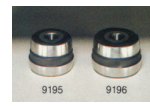

\$1,495.00

900006E

For most cars and light trucks through one ton applications; uses a double chuck to replace many cones.
\$1,349.00

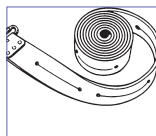

5280

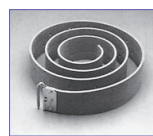

5290



6920

Drum & Rotor Silencers

Ascot #	Part #	AMMCO Description	Price
416-05280	5280	Silencer Band - Drum 1-3/4"	\$29.95
416-05290	5290	Silencer Band - Drum 2-3/4" Truck Drums	\$39.95
416-06920	6920	Silencer Band - Ventilated Rotor	\$23.32
416-06921	6921	Silencer Band - Non-Vented Rotor 6.5" (Pkg 2)	\$7.28
416-06922	6922	Silencer Band - Non-Vented Rotor 9.250" (Pkg 2)	\$7.28
416-06930	6930AM	Silencer Band - Rotor - Heavy Duty. Ventilated	\$19.95
416-07075	7075	Rotor Friction Silencer for 2002, 4000, 4100, 7000	\$199.95
417-08500	8500	Drum Micrometer	\$299.95
416-08756	8756	Abrasive pads for 8750	\$10.95
416-09183	9183	Replacement Pressure Pads - Non-Asbestos (Pkg 2)	\$10.95
416-09800	9800	Silencer Assembly - Spring - Vented - Rotor	\$29.95

Now! **06610 round bits**
Faster turn!

Round Carbide Bits for all Tool, Ammco, Hunter BL500 series, Performance and Rels lathes.

Use with 06700 holder. **\$84.43**



10 pk

06610 - **\$59.53**



Why pay for propellant?

Sure-Shot Sprayer

Great way to dispense brake cleaner and other chemicals. To operate, load liquid and pressurize with air chuck. Easy!

Ascot #	McGee #	Description	Price
632-00052	2000	1 Qt Rust Resistant Chrome Plated Brass Tank	\$73.57
632-00010	SS10	Repair Kit for 2000	\$19.83



Coats 12503DV Balancer Top-of-the-Line Direct Drive Workhorse!

Control Panel with Integrated LCD display... delivers

custom animation with step by step instructions to guide the technician with proper balancing techniques

Simultaneous display of static & dynamic data... identifies any excess residual static imbalance

EB Balancing Mode... Balancing wheel assemblies using COATS EB often results in the application of less corrective weight.

Hood Sonar... quickly measures the width dimension

Automatic offset and diameter data entry

Direct TAW Placement and Laser Guided Operation eliminates guesswork, resulting in 1-spin TAW balances

Easy Behind the Spoke Weight Placement helps maintain a "clean" look on custom wheels

Requires Adapter Kit & Peg Kit 8111480



\$5995.00

Coats 1000 Balancers

The Model 1000 Balancer has the mechanical and electronic power to be a key tool in high volume shops.

- 1-1/2 horsepower direct-drive motor and 16-bit microprocessor provide super-fast five second cycle times.
- Eight separate balancing modes (static and dynamic modes, RV and four different alloy modes, plus match mount).
- Operator "A" and "B" feature so two technicians can use at once.
- Convenient keypad entry
- Keyboard activated "hood start"
- Ounce/gram selectable readings with roundoff.
- Self calibration 220V 1 ph
- Basic adapter kit included.



1000CO

Limited Quantities!

\$3195.00

\$28.95



Model #61123 Calipers and Related Items
482-89011
Caliper Assembly - For Models 600, 650, 700, 850, 950, 1001, 1004, 1050
Works on any passenger balancer.

\$6.95



Model #308820 1.125" i.d. - Adapters, Cones & Face Plates
Spring - For Models 600, 650, 700, 850, 950, 1001, 1004, 1050, 1055 (3 Cone System - From March 1992) 40 mm

\$172.40



Model #5009998 08 40mm I.D. - Shaft, Hubnuts, & Press Drum
Part #85009998
Nut-Slide, 2 Jaw, 40mm w/drum, for use on 700-1250 models with 40mm shaft 28mm 5009998

\$79.95



Model #112103
Part #8112103 08 40mm I.D. - Shaft, Hubnuts, & Press Drum
Hub Nut, Handle, Solid, 45mm for standard thread pitch (not for XR-Series) 28mm - 110543

\$236.93



Model #5009009
Part #85009009 08 40mm I.D. - Shaft, Hubnuts, & Press Drum
Shaft - 40mm for 775/875/1175 & 6275 models, 4.23 mm Pitch. Call for the right shaft for your balancer.

Truck Cone Kit

MFG#113276 482-11559

MFG#113277 482-12385

\$268.68

Allows balancing truck wheels with center holes from 4¹³/₁₆" to 6⁷/₈". Used on rims with an alignment pin on the back. Double-sided cone fits all Coats balancers with 1.125" shafts. 40mm. 113277 or 113276 - 28 mm



Hold Down Cone

Part # 108276
444-81891

Fits All Except 10-10

Special **\$49.95**



Tire Spreader

Part # 108028
605-08028

For Coats Center-Post Tire Changers

Special **\$69.95**

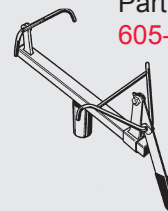

COATS® RIM CLAMP® WHEEL PROTECTION ACCESSORIES

\$32.33/pkg
444-83604
183604 Quilted Clamp Sock (Package of 10)



444-83606
183606 BL Shoe Sock (Package of 2)
\$29.95/pkg



- Decrease the chance of damaging expensive alloy wheels by putting a "sock" over three Rim Clamp action points and eliminate metal to metal contact.
- Put your profits into the bank, not into replacing alloy wheels.
- The above socks fit all COATS Rim Clamp models.

TIRE CHANGERS

"Perfect for low profile tires"

Model 70 Series Rim Clamp

New Robotic Arm

CALL FOR PRICE!

Robotic Arm Benefits
 Holds bead in drop center position.
 Holds tire in up position to reduce effort in second bead removal.

Specifications
 Clamping 10" - 24"
 Rim Width 3" - 14"
 Tire Diameter 50"



COATS® Model 4050A - Center Post Tire Changer



This double cylinder, air-powered unit features a large, on-board surge tank for fast bead seating and tire inflation. Designed for ease of operation, this industry "workhorse" boasts a redesigned bead loosening shoe.

CALL FOR PRICE!

50X Series Hig Volume Rim Clamp® Tire Changer

- Exclusive pedal-actuated X-shaped taletop provides support for the most delicate wheels
- Handles broad range of wheels and tires, from 6" to 26" in diameter and rims up to 14" wide
- 1.5 HP air drive system provides plenty of power plus infinite wheel control
- Built-in bead sealing jets and tabletop inflation for faster work
- Also available in electric versions



Colorado
 Bob Poindexter



Hablo Espanol!
 Rich Caballero

Equipment Specialists

1-800-525-8888

The next generation COATS Pro Guard – Designed for run-flat and low profile application

TILT BACK TOOL TOWER **\$9195.00**
 Limited Quantities!

The tool head and Leverless Power Duckhead® Bead Lifter are mounted to a traditional tilt back tower that stows out of the way when not in use. It also retains your tool head height settings for the next tire.

BEAD LOOSENER DISC AND TOWER

Loosen beads easily and effectively with unmatched precision. The easy-to-use controls keep the disc at the proper location on the tire—safely away from the wheel. And after you clear the rim edge, the disc advances to maintain pressure on the bead, not the sidewall—with the press of one button. You can even lock in your settings for the next wheel.

ROBO-ARM®

This powered assist device is a must have for mounting run-flat and low profile tires. The Robo-Arm® effortlessly keeps the top bead in the drop center while servicing even the toughest applications.



Handles rims
 10" to 34"!

PROTECTIVE PEDESTAL & CENTER LOCK DESIGN

Whether you're working a regular or reverse mount wheel, this detachable center post locks it securely in position right at the strongest part of the wheel. Plus, a non-marring replaceable cover protects even the most delicate wheels.

BUILT-IN ADJUSTABLE WHEEL LIFT

Controlled through an easy-to-reach pedal, the automated wheel lift eliminates the strenuous process of manually placing heavy tire and wheel assemblies over the clamping chuck.

LEVERLESS POWER DUCKHEAD® BEAD LIFTER

The leverless design eliminates traditional tire tools that can mar the surface due to application difficulty or operator error. This results in a more controlled mount/demount process, flexing the beads just enough for removal or installation.

Call for a free demonstration!

Rema Euro Paste \$12.95



432-00750 #75 - Mounting Paste 7.7 lb.
Eases mounting of stiff, low-profile tires. Aids in faster bead sealing during inflation. Preferred when servicing tires on ABS-equipped or HP vehicles. Prevents vibration complaints as a result of tire moving on wheel after balancing.



Neutral in pH and eliminates rim corrosion. Helps keep equipment cleaner. High performance mounting paste is premixed to prevent incorrect mixing of water to liquid concentrates.

437-43006 #73 - Brush, Angled Applicator \$10.59
Allows for proper application of mounting paste.

5500 Low Profile Bead Lever Tool

Patent Pending



Designed by technicians to assist with hard to change low profile tires.

The easy grip ergonomically designed handle allows the user needed leverage for the toughest of sidewalls while remaining a safe distance from the face of the wheel.



Now \$49.95

Plastic Inserts for 182788 Metal Mount/Demount Head (Pkg of 2) Model 182961
444-82788 \$5.60



Plastic Inserts for 182788 Metal Mount/Demount Head (Pkg. of 12) Model 182963
444-82963 \$22.70

Mount - Demount Tools

Part # 000768
444-00768

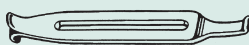

For All Center-Post Tire Changers

Special \$64.95

Part # 181354
444-81354

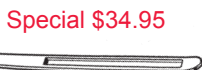

Special \$34.95

For All Rim Clamp Tire Changers

Drop Center Tool

Part # 435685
444-35658



Special \$39.95

A Must for "V" & "Z" Rated Tires

Plastic Duckhead Kit

Part # 183061
444-01220



Special \$26.85

Head, Mount/Demount, Polymer

Hunter TC3250/3500 - Black - \$19.95
(1 ea.) **Part #RP60343B 444-01221**



(1 ea.) **Part #221 6752 - Red**

Hunter polymer duckhead for TC tire machines - \$20.45 ea.

Part #RP118314813 - Plastic Duckhead for Hunter TCX tire machines - \$32.95 ea.

New Grip Max standard on X models \$469.75

Challenge: Damage-free clamping of alloy wheels

- Plastic clamp covers are missing, or are not installed by technicians, resulting in metal-to-metal contact with wheel
- Current plastic clamp covers are difficult to use on stiff-sidewall applications.
- Chromed wheels can slip during service while clamped externally.



Part No. 85000758 (Set of 4)

8500059408 replacement grip
\$30.78 (8 each)

Maximum Grip Minimum Risk

Lt Spare Tire Removal Tool Set

- Lower spare tire in 10 seconds
- Eliminates hunt for customer's tool
- Hanger included
- Do not use impact wrench
- 7 piece kit

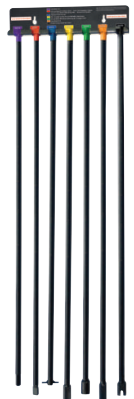

\$69.95 - #96090A

Protector Booties

Part # 108397
444-08397 Special \$1.76



Mount End

Part # 108398
444-08398 Special \$1.76



Demount End



Tire Changer Lube Bottles And Swabs

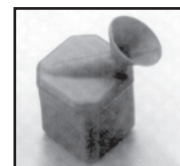

844-16572



844-16259

Ascot No.	McGee	Description	Price
844-16572	106572	Lube Bottle. Center-Post. Fits 4040, 4040SA and 4050 Tire Changers	\$9.95
844-16529	106259	Lube Bottle. Rim Clamp®. Fits RC-15, RC-20, 5060 and 5070 Tire Changers	\$8.95

Lube Swab

000491 **437-00491**





World Leader in Lift Systems

The World's Most Trusted Lift . . .

Since 1925, Rotary Lift has built quality in to everything we do. As the oldest U.S. lift manufacturer, our lifts are built and cycle tested for years of trouble-free service. Rotary lifts are backed by full warranty and are supported by McGee Company.

10,000-18,000 lb. 2 Post

Symmetrical Design

Wider drive-thru — perfect for trucks and vans

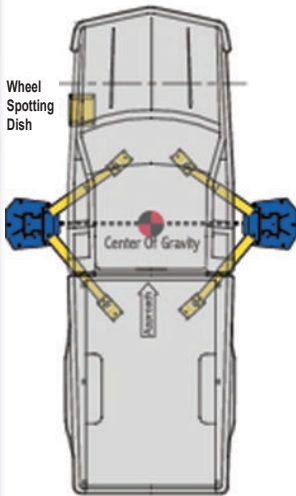

Vehicle Center of Gravity

- “Double S” column design maximizes the strength of the column and surface contact area of the bearings
- Single point lock release disengages the locks at the same time
- Full stroke cylinders in each column
- Arm restraints on each arm engage when the vehicle is lifted
- 3-position spotting dish

The new Y12 lift - general service or alignment
Call today for details 800-525-8888

Y12-Wide Wheelbase Range - Flat Top Surface

Flush Mounted or Recessed



Shown: YA12NX
 12,000 lbs. capacity

12,000 lb. Capacity

- 33% faster speed of rise
- Hydraulic cylinder, locking mechanism and position sensor are protected inside and under the runways

Narrow Bay and Low Ceiling Model Available!

Model shown: SPO15N310BL



15,000 lbs. Capacity

Arm Adapters Packages

10,000 lb. capacity lift:
 Three-Stage Flip-Up Adapters with built-in truck adapters on standard arms

12 to 18,000 lb. capacity lift:
 Thread Up Stackable Inserts designed for heavier vehicles, (additional stack adapters available)

TA Adapters also available for 10,000 lb. capacity lift

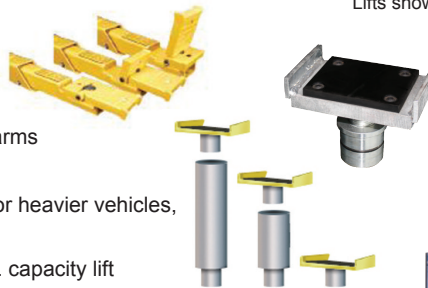

3 Stage Arms for Added Reach! Low Ceiling Available!



Model shown: SPO12N7T0BL

12,000 lbs. Capacity

Lifts shown with optional accessories

Two Post Lifts in McGee Inventory



Shown with optional accessories

ROTARY 10,000 lbs. - SPOA10 Asymmetrical Lifts

Face it — asymmetricals are in. Especially Rotary's. Because not only do our asymmetricals give you the most advanced design to avoid damaging your customers' car doors — they give you the most features.

Unlike a parallelogram, the YA12 provides true up/down lifting. There is no forward or rearward movement reducing valuable bay space.

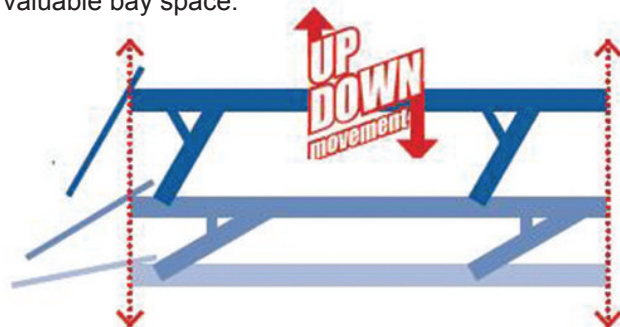

Protect on-board computer memory when disconnecting the battery! Prevent loss of stored vehicle codes!

Schumacher INC7A0BD

- Onboard diagnostics connector (OBDII) plugs directly into vehicle's OBDII Port.
- Preserves stored fault codes and programmed electronic settings such as clocks, radios, seat positions, keyless entry systems, alarms, etc.
- Durable 12 volt DC male-to-male connector with extendable cord allows flexible connection. For older cars.
- 7 amp hour battery
- Easy to ready battery status LED's - tell when internal battery is at full power, 75% charged or 50% or less and needs charging
- Built-in charger for automatic charging of internal battery
- Charging and charged LED indicators - indicates charging status of internal battery
- Convenient Velcro strap
- Lightweight and easily transportable



\$72.95



Schumacher INC-12V-0BD

- This accessory connector plugs the OBD II head into the car's OBD II source
- Protects vehicle fault codes, driveability codes, keyless entry codes and digital radio settings

Ascot No.	McGee No.	Price
343-12000	INC12V0BD	\$19.95

Schumacher SE6030

\$249.95

- Just like the SE-8050 but without testing capabilities, this heavy-duty model is also ideal for big fleet operations and industrial use. Perfect for situations that need a lot of power (including diesel engines). Two fat charge settings. Very high output engine start assists batteries in cranking most engines under severe weather conditions. For 6 and 2 volt batters. Fan cooled.



- 30 amp 12 volt/200 amp 6 volt engine start - for emergency starting
- 60 amp rapid charge - charges a battery in 1/2 to 1 hour
- 30 amp rapid charge - for very fast charging. Charges in 1 to 2 hours
- "Hold" position - for continuous charging
- Durable construction with tubular handle

Schumacher PSJ1812

\$119.95

- 1800 peak amps
- 280 cranking amps
- 225 cold cranking amps
- 12 volt DC power outlet
- 4 gauge, 28 inch cables
- Built-in automatic charger
- Charging and charged status LEDs
- Battery status LED
- Polypropylene case
- 18 Ah professional grade, high output AGM battery



72500 Transmission Jack

- 1/2-ton capacity
- Fully adjustable
- Built-in safety overload
- Foot operated pump
- Wide base for stability

72500.....\$799.00



Model 81033 and Model 81034—3/4 Ton Capacity

Designed to support vehicle components, not the vehicle. Ideal for exhaust system installation & shock absorber replacement.

- Light weight, slender design makes handling easy in close quarters.
- Quick adjust spin handle with trust bearing eliminates wear and provides ease of turning under load.
- Foot pedal (model 81034 only) generates 1" additional stroke and 400 pounds of force at the saddle.
- Pedal may be locked in vertical position for storage or shipment.
- 1-1/4" diameter threaded screw has 26-1/2" of travel.

81034.....\$94.95



The 7400 ... Better than ever!

The new Model 7400 has all the features you expect from Branick and more. It's the new answer for all your strut work. The 7400 can handle the heaviest coil-over-shocks, the Ford F-150 and even the Toyota RAV-4 without need for additional adaptors.

Extra long springs? Bring 'em on! Long, short, narrow or angled, the 7400 will easily do the job! And we're listening too... We opened up the front for easier access and added longer handles for extra torque. We also have an optimal benchmount and mobile cart.

SPECIAL \$659.95 (Stand sold separately)



Professional Workshop Vises

With high quality construction for extra durability and full-strength performance at any jaw opening, these vises are made for the professional -- strong, durable and built to last.

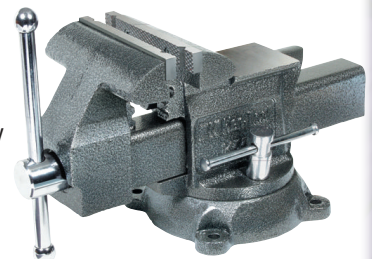

K65 6-1/2"

Model	Jaw Width	Jaw Opening	Throat Depth	Pipe Jaw Capacity	Weight	Price
K55	5-1/2" 14 cm	6-1/2" 17 cm	3-3/16" 8 cm	1/8" - 2-1/2" .3-6 cm	30 lbs 14 kg	\$139.95
K65	6-1/2" 17 cm	7-1/2" 19 cm	3-3/4" 10 cm	1/8" - 2-1/2" .3-6 cm	41 lbs 19 kg	\$189.95

AIR COMPRESSOR PRODUCTS

Quincy QT® Compressors — “Rated #1”



5-Year Warranty Program

- Quincy’s True Blue 5-Year Warranty
- Register unit within 10 days after purchase to activate warranty
- Purchase and use genuine Quincy filters and lubricant during the warranty period. (Proof of purchase required)
- Receive a 5-year limited warranty on the compressor.
- Receive a 2-year limited warranty on the package.
- Motors and engines are warranted by the original manufacturer.



253D80VCB-3MAG

Meticulously designed for maximum productivity. Completely rebuildable with stainless steel valves and heavy duty cast iron crank case and cylinders. Leading the industry with the most CFM per brake horse-power. Includes ASME receiver, enclosed belt guard, Epact high efficiency motor, and loadless auto stop/start.

Part No.	HP	Electric Spec.	ACFM at 175 PSI	Tank Size	Tank Style	Price
251CS80VCB-1MAG	5	230V, 1ph	17.2	80	vert.	\$2,295
271CS80VCB-1MAG	7.5	230V, 1ph	22.6	80	vert.	\$2,695
273D80VCB3MAG	7.5	230V, 3ph	22.6	80	vert.	\$2,395
P2103D12HCB3MAG	10	230V, 3ph	35	120	horz.	\$3,695
P2103D12VCB3MAG	10	230V, 3ph	35	120	vert.	\$3,995

Quin-Cip® Lubricant

Recommended for all Quincy Reciprocating compressors. Reduces carbon build up in the valves and extends the life of the compressor.

Think of your compressor as an investment—we do. That’s why we developed Quin-Cip to ensure the efficiency and performance of your investment. Quin-Cip protects against high temperatures and frictional wear of bearings and cylinders that can dramatically reduce the life of your compressor.



ELIMINATE WATER!

Where Water Comes From

The atmospheric air entering a compressor intake contains water vapor. Because of the effects of compression, most of this water vapor turns into troublesome liquid water in your air lines.

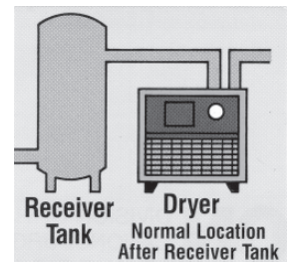

Always change compressor oil twice a year!

Part No.	Description	Price	Appl.
112542G068	20 weight gal.	\$25.71	warm
112542Q068	20 weight qt.	\$7.92	warm
112543G100	30 weight gal.	\$25.71	hot

Air Hose

McGee Company offers free assembly of air hose to your required length!



Rubber Air Hose

1/4", 3/8" & 1/2" Multi Purpose Air Hose Assemblies Smooth cover, 300 PSI W.P., 1,200 lb. burst. Limited oil resistance tube & cover. Red.

Mfg. No.	Description	Price
W64RJ25	25', 3/8" Male NPT Hose, 23/32" OD	\$23.95
W64RJ50	50', 3/8" Male NPT Hose, 23/32" OD	\$37.95
W84RJ25	25', 1/2" Male NPT Hose, 7/8" OD	\$32.95
W84RJ50	50', 1/2" Male NPT Hose, 7/8" OD	\$54.95

Call for price on bulk hose!

Mfg. No.	Description
W44RJR	1/4" ID, 5/8" OD, 700', 300 PSI
W64RJR	3/8" ID, 23/32" OD, 700', 300 PSI
W84RJR	1/2" ID, 7/8" OD, 700', 300 PSI

FILTERS — Remove Water, Oil & Rust from Air Lines - Metal Bowl

Ascot No.	Part No.	Description	Price
111-35200	F352W	1/4" Filter With Bowl	\$53.82
111-35300	F353W	3/8" Filter With Bowl	\$55.32
111-35400	F354W	1/2" Filter With Bowl	\$53.10
111-37600	F376W	3/4" Filter With Bowl	\$71.00
111-32908	F329-08W	1" Filter With Bowl	\$138.35



REGULATORS — Lets You Set The Required Air Pressure - Gauge not included - Metal Bowl

Ascot No.	Part No.	Description	Price
112-00352	R352	1/4" Regulators	\$40.80
112-00353	R353T	3/8" Regulators	\$40.80
112-00354	R354T	1/2" Regulators	\$45.40
112-00376	R376T	3/4" Regulators	\$59.40
112-00378	R378T	1" Regulators	\$59.40



LUBRICATORS — Supply a Fine Mist of Oil For Air Tools - Metal Bowl

Ascot No.	Part No.	Description	Price
113-01352	L352W	1/4" Lubricator w/Bowl	\$64.50
113-00353	L353W	1/2" Lubricator w/Bowl	\$71.80
113-00376	L376W	3/4" Lubricator w/Bowl	\$74.40
113-04108	4108W	1" Lubricator w/Bowl	\$120.00



Graco Enclosed Hose Reels

- \$199.95** 24H658X Air 3/8" x 50'
- \$249.95** 24H662X Oil 1/2" x 35'



Required inlet hose kit sold separately.

Features:

- Designed for light duty applications
- Enclosed for safety and protection, and extends hose life
- 5 year warranty

Pressurized Used Oil Receiver

- Easy to drain using shop air pressure
- Large 24 gallon capacity
- Large offset collection pan with screen
- Pressurized used oil receiver

119577 — Now! \$349.00

119577



Oil King

- Large 25 gallon capacity with sight gauge
- Convenient tool trays and filter areas
- Large offset collection pan with screen
- Oversized tires to get over hose and rough floors

238866 — Now! \$399.00

238866



Heavy Duty & High Quality

	HPM33B 25' OIL	\$369.95
	HPM65B 50' OIL	\$389.95

256215 — Rigid Extension

258693 — Flexible Extension

\$289.00

- ELECTRONIC
- LIGHTWEIGHT

LDM5

\$369.00

- ELECTRONIC
- PRESETABLE

SDM5

255350 — Rigid Extension

255348 — Flexible Extension

Graco Pumps & Accessories



\$345.95
24G576
LD Series
3:1

Affordable and full featured LD series is designed for lower volume applications.



\$485.95
246775
Fireball 225
3:1

Introducing Graco's classic Fire-Ball design in as a 3:1.



\$635.95
203876
Fireball 300
5:1

This pump has been the "crown jewel" of Graco since the 1950s and is the pump of choice in the most demanding environments.

Graco

AIR DIAPHRAGM PUMPS

- 3/8" **D31255** 7 GPM **\$299.95**
- 3/4" **241906** 15 GPM **\$399.95**
- 1" **647016** 40 GPM **\$599.95**



Square Stackable Rhino Tuff Tanks are available in 4 individual sizes including 80, 120, 180, and 240 gallons. All tank sizes can be stacked with each other, in any combination, without the use of any converting brackets. Rhino Tuff Tanks have been tested by a third party testing laboratory for dynamic compression, internal pressure and stack test evaluations. Tanks are designed to be placed on our factory designed HD Universal Tank Stand (sold separately) or flat surface.



RTT6222 Package - \$1599.00

Includes complete stand with drip tray kit, release valves, hoses, and three 120 gallon tanks!

Available for immediate shipment.

HYDRAULIC JACKS

3-1/2 Ton Professional Heavy Duty Floor Jack

Model 350GT

AFF's Model 350GT is "forge-tough" for daily service use. It is ideal for use in tire shops, mechanical repair facilities and roadside assistance service vehicles where ruggedness, strength and durability are required.

- Lifts from 4" to 19-1/2"
- Pinned steel saddle (1-1/8" stud) with rubber pad for added vehicle protection
- Rear mounted 2-3/4" swivel casters for ease of maneuverability
- High strength steel yoke
- One piece 50-1/4" padded handle parks upright
- Ship weight 117 lbs.

\$299.95



Jack Oil HF100
\$6.75 Qt.

3-1/2 Ton Professional Heavy Duty Double-Pumper Floor Jack

Model 350SS

\$319.95

This unit offers all the features of our Model 350GT with additional speed and efficiency thanks to AFF's double-pumper advantage for quicker lifting.

- Lifts from 4" to 19-1/2"
- Pinned steel saddle (1-1/8" stud) with rubber pad for added vehicle protection
- Rear mounted 2-3/4" swivel casters for ease of maneuverability
- One piece 50-1/4" padded handle parks upright
- Ship weight 119 lbs.



Replacement power unit for the 350 Series and 200T Jacks

Before you replace your jack, consider installing a new power unit

350GT Jack Power Unit is 350GT-KHU

350SS Jack Power Unit is 350SSKHU

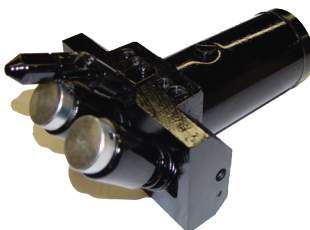

\$109.95 ea. for all 350 and 200 models



FREE!

Model 3306 (one pair)

Buy 350SS & get two 3306 6 ton ratchet style jack stands FREE!

"THE BEST WARRANTY IN THE INDUSTRY"

McGee Company offers one year over the counter warranty on the 3-1/2 Ton - 350GT Service Jack. Ask your McGee representative for details!

**NORCO • OTC
AFF • HEINWERNER**



Jack Stands

6-Ton AFF3306..... **\$61.95/pr**
12-Ton AFF3312 (81012)..... **\$149.95/pr**

- Ratchet style
- Heavy steel

Bottle Jacks

- Extension screw on some models
- Rust protection covering
- Uniweld construction
- 50% overload factor
- Fewer moving parts

ZN12 12-Ton..... **\$84.95**
ZNB22 22-Ton **\$129.95**



Air/Hydraulic Truck Service Jack

Designed for tire and wheel service on trucks, tractors and OTR vehicles. Includes return springs.

565E 22-Ton **\$549.95**

565E has one piece handle and includes extension set!

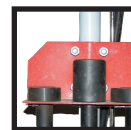

72200D Norco 22-Ton **\$629.95**



20 Ton Capacity Air/Hydraulic Bottle Jack

- Operates manually or with air eliminating hand pumping.
- Automatic bypass system.
- Extension screw provides extra lifting range
- Heavy duty base.
- Can be operated horizontally.
- Factory pretested

5520B **\$219.95**



"One Year Over-the-Counter Warranty"



ALIGNMENT SOLUTIONS

#67290

\$81.⁹⁵ Kit



HONDA/ ACURA EZ ARM XR™

These rear arms are for Accords, Pilots and more. An O.E. ball joint is integrated into this arm. Perfect for stock height and lowered vehicles.

Call us for more
Honda/Acura Alignment
Solutions from '88
CRXs to the Newest
Multi-link Accords

Rear Adjustment range:
Camber -2.00° to +4.00°

Installation time: .5 hr/side

Required: 1 kit per wheel

APPLICATIONS

Acura: 2001 - 06 MDX,
2004 - 06 TSX

Honda: 2003 - 07 Accord,
1999 - 04 Odyssey,
2003 - 06 Pilot

#87520

\$27.⁹⁵ Kit



NISSAN CAMBER/ CASTER KIT (2)

These cams are designed to install in the lower control arms for camber and caster adjustment. They replace the original non-adjustable lower control arm bolts.

Front Adjustment range:
Camber ±2.00° Caster ±2.50°

Installation time: .3 hr/side

Required: 1 kit per wheel

APPLICATIONS

Infiniti RWD & 4WD: 2004 & Up QX56

Nissan RWD & 4WD: 2004 & Up Titan,
2005 & Up Armada, Frontier, Pathfinder, Xterra

#23940

\$94.⁹⁵ Kit

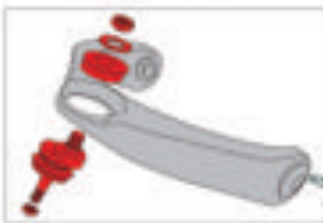

DODGE 1500 OFFSET BALL JOINT

Lifted or lowered, factory cams don't give enough adjustment range on the Dodge Ram 1500 series of trucks. Gain 2" of camber or caster with these offset ball joints. Simply replace the ball joint in the stock upper control arm to get ±2" caster, cambec, or a split and then dial in final adjustments with the factory cams. Bring ride quality and tire wear back into the green for your customer.

NEW!

Front Adjustment range:
Camber ±2.00° OR
Caster ±2.00°

Installation time: .6 hr/side

Required: 1 kit per wheel

APPLICATIONS

Dodge 4x4 and RWD:
2006 & Up Ram 1500

#86250 FORD ADJUSTABLE CAM NUT/ BRACKETS

\$30.²³ Kit

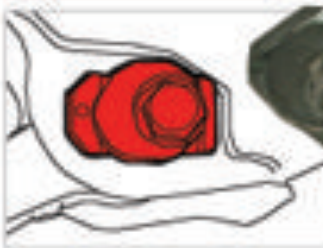

The innovative cam nut and sturdy bracket saves time and money. Easily adjust camber and caster on F150's from '04 and up (including late model) and '07 & up Expeditions. No need to remove the OE bolt or stabilizer bar. The sturdy guide bracket allows for live adjustment. This is a must have for every 2004 - up F150 and 07 - up Expedition.

Front Adjustment range:
Camber ±1.00° Caster ±1.50°

Installation time: .3 hr/side

Required: 1 kit per wheel

APPLICATIONS

Ford: 2004 & Up F150
2007 & Up Expedition
Lincoln: 2006 & Up Mark LT
2007 & Up Navigator

#87385 F150/250 (L/D) 2/4WD KIT (4)

\$36.⁸⁵ Kit



Make caster and camber adjustments on these popular SUVs. This part replaces the original equipment upper control arm bolts and allows for easy adjustment of caster and camber. Estimated installation time is only 1/2 hour per side. Use Specialty Tool #87155 to make easy adjustments.

Front Adjustment range: Cam./Cas. ±2.00°

Install time: .4 hr/side • Req: 1 kit per axle

APPLICATIONS

Ford: 1997 - 03 2WD & 4WD F150, F250 (L/D),
1997 - 02 2WD & 4WD Expedition, 2004 F150
Heritage.
Lincoln: 1997 - 02 2WD & 4WD Navigator.

HUNTER Engineering Company

Hunter is changing the game again!



Hawkeye Elite

- ✓ New adaptor for faster setup and faster readings
- ✓ QuickComp allows compensation in one forward roll
- ✓ Codelink allows steering system reset at end of alignment

**LEASE FOR
\$27 A DAY***



New Alignment Machines starting at

\$10,500

*Based on 60 month lease WAC. Taxes not included.

A McGee Company equipment representative can help you select the right tire changer and balancer

Own for as little as \$6 a day!*

- ✓ Familiar table top design for high volume shops
- ✓ Bead depress arm for mounting low profile tires
- ✓ Steel or polymer head design for any wheel



TCX515

Own for as little as \$5 a day!*

- ✓ Strong Servo 220v drive motor
- ✓ Data Set Arms for quick wheel specs
- ✓ Split Spoke® and Split Weight Modes for high end wheel balancing



DSP9200 Balancer

Call for pricing

- ✓ Change wheels up to 34"
- ✓ Leverless head design eliminates rim damage
- ✓ Wheel lift option to eliminate heavy lifting



Auto34



Designed for the car enthusiast or the automotive shop with the need to lift vehicles occasionally



Direct Lift 9,000 lb., 10,000 lb. and 12,000 lb. Two Post Lifts

PV12

The Direct Lift Pro V12 is a commercial grade 12,000 lbs. capacity 2 post lift. The Pro V12 is perfect for lifting your large vans and dually trucks. It comes with a free set of truck adapters and all of the mounting hardware. With a dry weight of 2,250 lbs., there are very few commercial lifts that can even come close to the value offered with the Pro V12.

Features:

- Commercial grade
- Single point lock release
- Overhead model
- Powder coat finish
- 12,000 lbs. capacity
- 13'8" or 14'8" tall (depending on how the column extension is installed)
- Truck adapters included
- Symmetric post design
- Anchor bolts included
- Available in **blue** color only

Specifications:

- Capacity 12,000 lbs.
- Overall height 164" (13'8") or 176" (14'8")
- Lifting time 55 seconds
- Between columns 123 1/2"
- Drive through 112 1/2"
- Maximum lift height 79"
- Overall floor width 150"
- Low arm height 6"
- Shipping weight 2,250 lbs.



Pro V12
Two Post Lift



PP8S Four Post Lift
\$2,095.00

- 8,000 lb. capacity
- Exclusive adjustable lock ladder leveling system
- ALI/ETL Certified
- Powder coat finish
- Single point lock release
- Steel approach ramps included
- FREE jack try included
- FREE wheel caster kit
- FREE drip trays (4) included



Pro 9F Two Post Lift
\$2,095.00

- 9,000 lbs. Capacity
- Ideal for low ceilings in shops and garages—overall column height of 9'3".
- Comes with FREE truck adapters and mounting hardware



PV10 Two Post Lift
\$2,395.00

- 10,000 lbs. Capacity
- Symmetric column configuration offers widest drive through possible.
- Comes with FREE truck adapters and mounting hardware
- (Limited Quantity)

PV12
Sale Price
\$2,995!
(Limited Quantity)

Direct-Lift Warranty

Two Post/Four Post, Vehicle and Specialty Lifts weight capacity models 7,000 lbs. through 14,000 lbs. are warranted for (5) years on structural components and (2) years on hydraulic power units and cylinders from invoice date. Low Rise and Mid Rise Lifts weight capacity models 6,000 lbs. are warranted for (2) years on structural components and (2) years on hydraulic power units and cylinders from invoice date. Rotisserie units, Motor Cycle Lifts, Jacks, Lift Accessories, Jack Stands and Lift Kits, etc. are warranted for (1) year on structural components and (1) year on air/hydraulic power units, pneumatic cylinders and components from invoice date.

Prices: Prices are subject to change and do not include freight, delivery, or site inspection.

