

McGEE COMPANY

SINCE 1951



Denver • Salt Lake
Albuquerque • Dallas

1-800-525-8888

www.mcgeecompany.com



Automotive Service Equipment

Tire Service Supplies

Retreading Equipment & Supplies

Passenger/Truck/OTR

EXPIRES 1/30/15

All prices are F.O.B. our warehouse unless otherwise specified. Lease figures are approximate and subject to change.

PRICES SUBJECT TO CHANGE
VISA AND MASTERCARD ACCEPTED



Coats • Hunter • Procut

Changers, Balancers, Lathes

Hunter • Cemb • Rotary

Alignment Equipment

Rotary • Norco • OTC

Lifts, Hydraulics, Jacks

Hosetract



AIR • OIL • WATER
GREASE • ANTIFREEZE

3/8 in. x 50 ft. hose reel

Ascot LC350 - **\$249.95!**
125-35000

Designed for heavy volume.

HOSE REELS FOR EVERY APPLICATION

The 7600 ... Better than ever!

The new Model 7600 has all the features you expect from Branick and more. It's the new answer for all your strut work. The 7600 can handle the heaviest coil-over-shocks, the Ford F-150 and even the Toyota RAV-4 without need for additional adaptors.

Made in USA.

Extra long springs? Bring 'em on! Long, short, narrow or angled, the 7600 will easily do the job! And we're listening too... We opened up the front for easier access and added longer handles for extra torque. We also have an optimal benchmount and mobile cart.

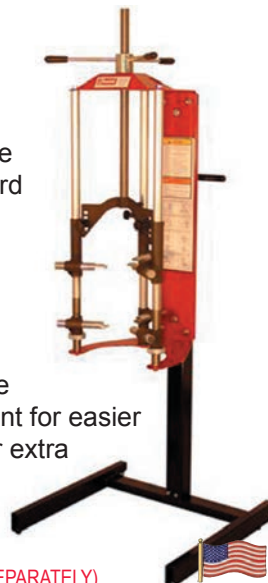

SPECIAL \$689.95 (STAND SOLD SEPARATELY)

5-Gallon Cheetah Tire Bead Seater **\$219.95!**

473-00500 CH5

- Makes seating the most difficult bead safe, simple
- 5-gallon capacity
- Designed for commercial use on large truck tires, passenger and ATV tires to 24.5"
- Fill tank from any service station chuck or service truck air compressor



Digital Hand-Held Tire Inflator*

\$89.95!

- INFLATION RANGE: 0 - 174 PSI
- ACCURACY: +/- .2 PSI • 6' Hose
- Lightweight shock-resistant design
- High specification ceramic sensor
- Long life, easily replaceable battery
- Available in custom hose lengths and chuck styles
- Valve has provisions for checking air pressure during inflation
- Threaded for 1/4" male NPT hose fittings



477-10001

| ASCOT NO. | McGEE NO. | DESCRIPTION |
|-----------|-----------|---------------------------------|
| 477-10001 | 47710001 | Digital Hand-Held Tire Inflator |

* This gauge provides more accurate air pressure readings which is essential with TPMS.

Deluxe Wheel Lock Removal Set

The Deluxe Hubcap and Wheel Lock Removal Set safely removes and replaces GM, Ford and Chrysler wire wheel hubcap locks on 1978 and up vehicles. Variable drive keys will also fit Corvette, McGard hubcap locks and aftermarket wheel lug locks. Kit comes in a durable plastic carrying case with instructions. Includes 4200A twist socket remover.

401-02841 - LT400 - \$89.95



TIRED OF STOCKING BULKY, HEAVY CHAINS?



Easy and fast to fit and remove, even in cold and difficult weather

Highly effective temporary aid on snow and ice

Tested and approved by TÜV, an independent road and transport research institute in Germany

Lightweight and easy to store

Quiet and not noticeable while driving

Approved for use by leading car manufacturers

Works with all electronics (traction control systems, ABS)

Does not cause damage to rims, suspension or body

Usable with alloy rims – even when snow chains must not be mounted!

Meets CDOT criteria in Colorado as an alternative traction device to tire chains for trucks, and Onorm Austrian strict chain requirements for passenger and truck vehicles

Now meets Washington, Oregon, & California requirements as an alternative traction device to chains for cars and trucks

Perfect for buses with minimum clearance



Approved across the USA as alternative to chains*

*Except in Nevada

AutoSock for Passenger Cars - Max. Traction Force on Snow

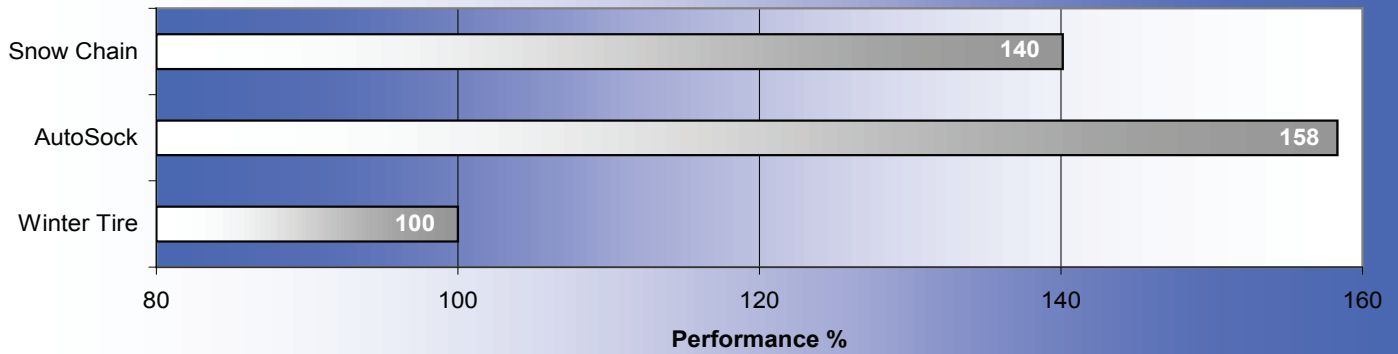

| | | | | |
|-------------------------|---------------------------|-----------------------|-----------------------|---------------------------|
| DATE: Dec 06 2007 | AIR TEMP.: -7°C/25°F | TIRE SIZE: 205/55 R16 | INFLATION FA: 3.0 bar | TEST VEHICLE: Pontiac FWD |
| LOCATION: Loveland Pass | CONDIT.: Dry snow, cloudy | ABS: on | INFLATION RA: 3.0 bar | TEST SURFACE: Packed Snow |

AutoSock for Truck - Max. Traction Force on Snow

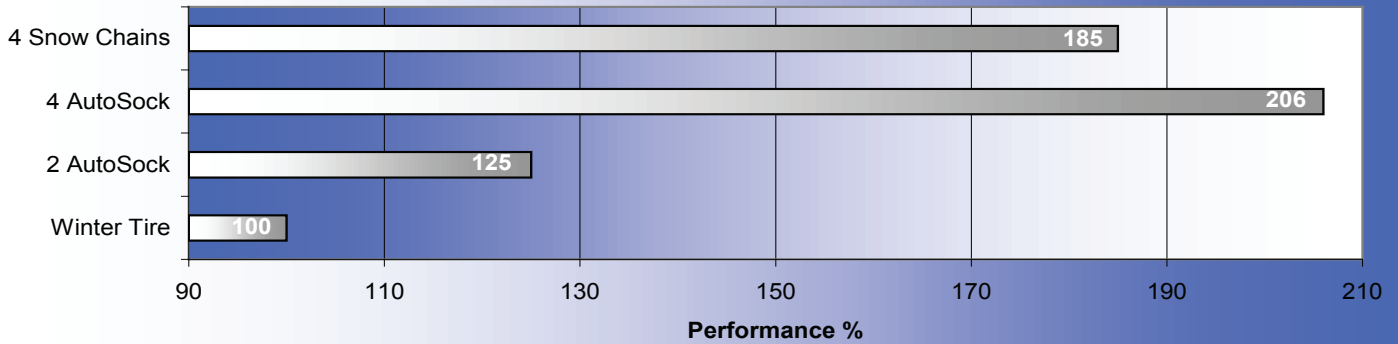

| | | | | |
|-------------------------|---------------------------|-------------------------|-----------------------|---------------------------|
| DATE: Dec 06 2007 | AIR TEMP.: -7°C/25°F | TIRE SIZE: 295/70 R22.5 | INFLATION FA: 8.0 bar | TEST VEHICLE: Peterbilt |
| LOCATION: Loveland Pass | CONDIT.: Dry snow, cloudy | ABS: on | INFLATION RA: 8.0 bar | TEST SURFACE: Packed Snow |



Showroom displays available for truck or auto with video. Call Today! 800-525-8888

- **Over 2 million pairs sold worldwide**
- **Now available for all popular passenger and truck tire sizes, even super singles**
- **Mount on any truck or car in less than five minutes**



More information at www.autosock.us

Garage Exhaust Hoses & Vehicle Protection

Tire Bags, Seat Protectors, Steering Wheel Covers, Paper Floor Mats, Parts Bags

Tailpipe Adapters



- Crushproof offers a complete line of accessory items
- Parts depicted below are the result of years of accumulated customer input, Crushproof's technology and extensive field testing

| Ascot No. | Mfg. No. | Adapter Description | Tailpipe Style | Tailpipe Size | Hose I.D. | Price |
|-----------|----------|-----------------------------|----------------|-----------------|-----------------------|---------|
| 391-93000 | TPA3000 | Split Adapter | Separated | Up To | 3" 2-1/2" | \$75.42 |
| 391-90250 | F250 | Straight w/ Hook & Chain | Single | Up To 2" | 2-1/2", 3", 3-1/2" | \$17.72 |
| 391-90300 | F300 | Straight w/ Hook & Chain | Single | Up To 2-1/2" | 3", 3-1/2" | \$23.99 |
| 391-90400 | F400 | Straight w/ Hook & Chain | Single | Up To 3-1/2" | 4", 5" | \$48.44 |
| 391-91250 | RA250 | Bell w/Snaps | All | All | 3" | \$29.05 |
| 391-91300 | RA300 | Bell w/Snaps | All | All | 3" | \$29.05 |

Crushproof Exhaust Ventilation System

Door Ports



Y-Connectors



| Ascot No. | Mfg. No. | Description | Price |
|-----------|----------|---------------------------|---------|
| 391-00125 | DF25 | 2-1/2" Rubber Door Port | \$23.52 |
| 391-00130 | ADF30 | 3" Aluminum Door Port | \$31.58 |
| 391-00140 | ADF40 | 4" Aluminum Door Port | \$42.41 |
| 391-00225 | RY25 | 2-1/2" Rubber Y-Connector | \$25.56 |
| 391-00230 | RY30 | 3" Rubber Y-Connector | \$26.85 |
| 391-00240 | AY40 | 4" Aluminum Y-Connector | \$68.86 |

Flarelock Exhaust Hose! Flared end permits connecting hoses!



- FLT250 - 11 ft x 2.5 in. **\$80.00**
- FLT300 - 11 ft x 3 in. **\$96.00**
- FLT400 - 11 ft x 4 in. **\$155.00**

Call 1-800-525-8888
Additional Items Available

Dispensing Racks

Centralize your cleanliness products for the professional image your business needs and the convenience your employees deserve. The top tray holds paper floor mats and elastic band steering wheel covers. Rollers are for seat covers, tire bags, and parts bags.

| Order No. | Description | Ship Wt. Lbs. | Price |
|-----------|---|---------------|---------|
| PSC | Seat Protectors - Roll of 500 | 20 | \$59.00 |
| SWC | Car Steering Wheel Covers - 500 pkg | 10 | \$42.00 |
| STB | Standard Tire Bag - Roll of 250 | 25 | \$51.00 |
| HDTB | Large Tire Bag for SUV - Roll of 250 | 30 | \$67.00 |
| FPFM | Heavy Duty Paper Floor Mat - Box of 500 | 50 | \$32.00 |
| WPB | Parts Bags, 12" x 20" - Roll of 500 | 15 | \$36.00 |
| DR | Dispenser Stand Only | 25 | 180.00 |
| 41110 | Large Tire Bag - Roll of 100 | | \$29.95 |



#WPB



#PSC



#SWC



#STB & #HTB & 41-110



#FPFM

Stud Gun, Studding Equipment



458-00010



458-00500

| ASCOT NO. | MFG. NO. | DESCRIPTION |
|-----------|----------|---|
| 458-00010 | 10-G | Stud Gun. Standard of the Industry. Automatic. Light weight. |
| 458-00002 | KFP2 | Stud Feeder. Fully automatic with 110 Volt motor, fast loading. Provides positive stud orientation. Feeds up to 225 studs per minute. |
| 458-04048 | 4048 | Feederboy Stud Gun. Designed for fast feeding studs of the AS-9 Gun. Attaches with screw clamp. Operates by manually turning the feeder cap. |
| 458-00005 | K-5 | Stud Feeder. INCLUDES: Shield for gun. Welded steel construction with saddle. |
| 458-00500 | K-500 | Studding Equipment Kit. INCLUDES: K-5 stand, AS-9 gun, KFP2 automatic stud feeder. |

Ugigrip®, Self-Adjusting Carbide Tire Stud

- Delivers full-time traction, increases the safety, convenience and security.
- To order studs to best fit your customers' tire, use the TSMI number recommended by the tire manufacturer



SINGLE FLANGE STUDS:

| TSMI Size | 11 | 12 | 13 | 15 | 16 | 17 | 19 |
|---------------------------|--------|--------|--------|--------|--------|--------|--------|
| Overall Length | .345" | .375" | .470" | .520" | .585" | .515" | .635" |
| Jacket Dia. | .197" | .197" | .197" | .197" | .197" | .197" | .250" |
| Bottom Dia | .354" | .354" | .354" | .354" | .354" | .354" | .354" |
| Nearest 32" to Hole Depth | 11/32" | 12/32" | 13/32" | 15/32" | 16/32" | 17/32" | 19/32" |

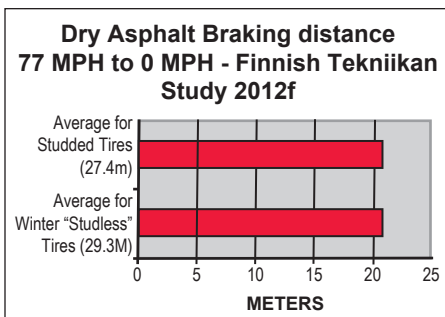
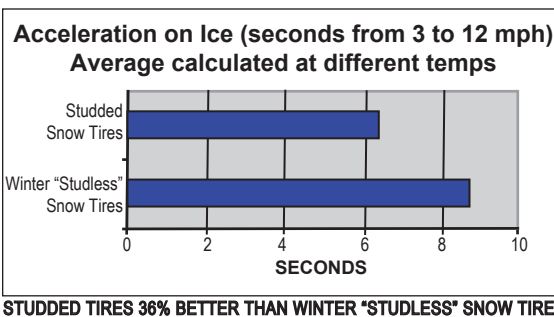
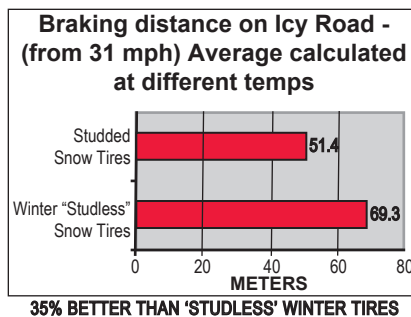

Parts Breakdown

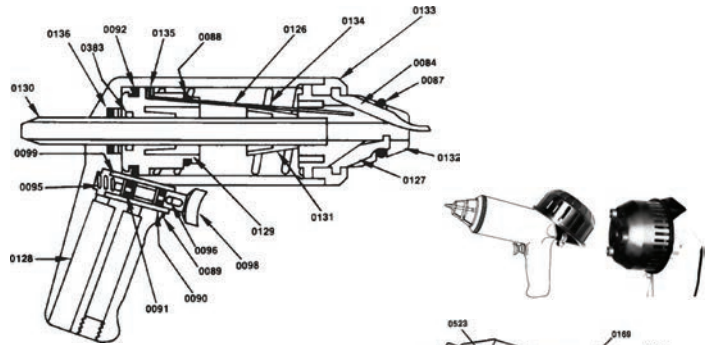

STUD GUN PARTS (AS-9 MODEL)

| Part No. | Description |
|----------|--------------------|
| 0084 | External Finger |
| 0087 | O-Ring |
| 0088 | O-Ring |
| 0089 | O-Ring |
| 0090 | O-Ring |
| 0091 | O-Ring |
| 0092 | Piston Cup |
| 0095 | Trigger Spring |
| 0096 | Trigger Pin |
| 0098 | Trigger |
| 0099 | Trigger Sleeve |
| 0126 | Pressing Spring |
| 0127 | Internal Finger |
| 0128 | Handle Body |
| 0129 | Piston |
| 0130 | Feed Tube |
| 0131 | Tapered Sleeve |
| 0132 | Head (Steel) |
| 0133 | Ring Nut |
| 0134 | Compression Spring |
| 0135 | Ring |
| 0136 | O-Ring |
| 0383 | Piston Cup |

STUD FEEDER PARTS (KFP2 MODEL)

| Part No. | Description |
|----------|------------------|
| 0169 | Deflector Spring |
| 0172 | Snap Ring |
| 0173 | Screw |
| 0174 | Washer |
| 0175 | Clamp |
| 0180 | Drive Shaft Pin |
| 0428 | Washer |
| 0519 | Feed Wheel |
| 0520 | Base Plate |
| 0521 | Retaining Ring |
| 0522 | Feed Tube |
| 0523 | Screw |
| 0524 | Shaft |
| 0525 | Hex Bolt |

Stud Gun Repair & Conversion Kits

| ASCOT NO. | STUDDING GUN | USE WITH STUDS NUMBERED |
|-----------|--------------|---|
| 458-03810 | 0381 | Tire Stud Mini Repair Kit. INCLUDES: (3) 0084 External Fingers; (1) 0087 O-ring; (1) 0088 O-ring; (3) 0126 Pressing Springs |
| 458-03820 | 0382 | Tire Stud Gun Large Repair Kit. INCLUDES: (6) 0126 Pressing Springs; (3) 0084 External Fingers; (2) 0087 O-ring; (2) 0088 O-ring; (1) 0092 Piston Cup; (1) 0136 O-ring |

TIRE CHAINS

Laclede Single Truck Chains

- Recommended for highway use
- Available in R— regular side chain
- Available with cam side chain



Alpine Premier

Laclede Alpine Premier Chains

- Diamond pattern design provides superior traction
- Installed without lifting or moving vehicle
- Recommended for class “S” cars and ABS systems
- Recommended for front wheel drive



| Tire Sizes | | | | Non-Cam Stock No. |
|-------------|-------------|---------------|-----------------------|-------------------|
| 7.00-14LT | P205/75R14 | 205/60R17.5 | | 2209R |
| 185-14 | 195/75R14LT | 28X8.50-14 | | |
| H70-14ST | | LR78-15 | 7.00-15LT 195/75R15LT | 2211R |
| H78-14ST | H78-15ST | 6.70-15LT | P215/75R15 7-17.5LT | |
| 9-14.5MH | P235/75R15 | 8.00-16.5 | 225/75R16LT 235/65R17 | 2216R |
| 215/75R14LT | 215/75R15LT | P225/70R16 | 255/75R16LT | |
| H78-15LT | 30x9.50-15 | P225/75R16 | P235/60R17 | |
| P225/75R15 | 6.50-16LT | 205R16 | P235/65R17 | |
| 7.00-15TR | 245/75R15LT | 235/75R16LT | 8-17.5 225/65R18 | 2219R |
| 7.50-15LT | 7.00-16LT | 245/70R16LT | 8.50-17.5 235/60R18 | |
| P275/60R15 | 8.75-16.5 | 255/65R16LT | 215/70R17.5 235/65R18 | |
| 235/75R15LT | 215/80R16LT | 8.75-16LT | P235/50R18 245/55R19 | |
| 245/70R15LT | 215/85R16LT | P235/70R17 | P255/45R18 | |
| NR78-15 | LR78-16 | 235/85R16LT | | |
| 7.50-15TR | 7.50-16LT | 7.00-17LT | | 2221R |
| 275/60R15LT | 9.50-16.5 | 215/75R17.5 | | |
| 7.50-17 | 245/70R17LT | 225/70R17.5 | 7.00-18 8-19.5 | 2214R |
| P245/65R15 | P245/75R16 | 265/60R16LT | P245/55R17 275/60R17 | 2229R |
| P245/70R15 | P255/65R16 | 275/60R16LT | P245/65R17 P255/55R18 | |
| P255/70R15 | P255/70R16 | 30X9.50-16LT | 245/65R17 255/55R18 | |
| P265/70R15 | P275/60R16 | 31X11.50-16 | P245/70R17 255/60R18 | |
| P265/75R15 | 235/70R16LT | 32X9-16LT | P255/55R17 235/55R19 | |
| 255/75R15LT | 235/80R16 | 32X10.00-16LT | P255/60R17 | |
| 29X9.50-15 | 245/75R16LT | 10-16.5LT | P255/65R17 | |
| P235/70R16 | 255/70R16LT | 225/75R17LT | P275/60R17 | |
| P245/70R16 | 265/50R16LT | P235/75R17 | | |
| 8.25-15TR | 255/85R16LT | | P275/60R20 | |
| P275/70R16 | | 275/55R20 | 245/70 19.5 | |
| 7.50-18 | 265/70R19.5 | 6.50-20 | 7.00-20 | |
| 9.00-15TR | 9R17.5 | | 8-22.5 255/70R22.5 | 2237R |
| 9.00-16LT | 10R17.5 | 7.50-20 | 235/80R22.5 | |
| 10-15TR | 8.25-20 | 245/75R22.5 | 275/70R22.5 | 2239R |
| 11R17.5 | 9-22.5 | | QR78-16 | |
| 9.00-20 | 10-22.5 | 255/80R22.5 | 265/75R22.5 | 2241R |
| 10.00-20 | 11-22.5 | 275/80R22.5 | | 2245R |
| 295/75R22.5 | 305/70R22.5 | 285/75R24.5 | 275/80R24.5 | 2247R |
| 10.00-22 | 11-24.5 | | | 2249R |
| 11.00-15TR | 11.00-20 | 12-22.5 | 12.5-22.5 295/80R22.5 | 2251R |
| 12.00-20 | 13/80R20 | 11.00-22 | 315/80R22.5 12-24.5 | 2255R |
| 13.00-20 | 14/80R20 | 365/80R20 | 12.00-24 | 2257R |

| TIRE SIZES | | | | STOCK NO. |
|--|--|--|--|---|
| 12" & 13" RIMS | 14" RIMS | 15" RIMS | 16" & OTHER RIMS | |
| 145R12 P145/80R12 | 155R12 P165/70R12 | | | 1505 |
| 145R13 P145/80R13 P155/70R13 | P165/65R13 P165/70R13 P155/60R15 | | | 1510 |
| 155R13 P155/80R13 | 175/60R13 P185/60R13 | 165/65R14 P175/60R14 | 135R15 | 1515 |
| 165R13 P165/80R13 | P175/70R13 P195/60R13 | 165/70R14 P175/65R14 | 145R15 P175/55R15 | 1520 |
| 175R13 P175/75R13 P175/80R13 P185/70R13 P195/70R13 | P205/60R13 | 165R14 P165/75R14 P175/70R14 P175/75R14 | P195/60R14 P195/65R14 205/55R14 P195/55R15 | 1525 |
| 185R13 P185/80R13 P205/70R13 | 175R14 P185/70R14 P185/75R14 P195/70R14 | P205/60R14 P215/60R14 185 6014 | 165R15 P185/65R15 P195/60R15 P175/70R15 P205/50R15 P185/60R15 P205/55R15 | 1530 |
| | 185R14 | P195/75R14 | 175R15 195/60R15 P185/70R15 195/65R15 | P190/65R390 1535 |
| | 195R14 P205/70R14 P205/75R14 P215/65R14 | P215/70R14 P225/60R14 P255/60R14 P255/70R14 | 185R15 P195/70R15 P205/60R15 P205/65R15 | P205/55R16 P205/60R16 P205/50R17 1540 |
| | 205R14 215R14 P215/75R14 | P225/70R14 P235/60R14 27X8.50-14LT | P195/75R15 P215/65R15 P205/75R15 P225/60R15 | P205/65R16 P215/55R16 P215/60R16 P215/70R17 1545 |
| | P225/75R14 P245/60R14 | | P265/50R15 | P205R16 P215/55R17 1547 |
| | | 205R15 P215/70R15 | P215/75R15 P235/60R15 | P215/65R16 P215/70R16 P225/55R16 P225/60R16 8.00-16.5 P225/50R17 1550 |
| | | P225/70R15 P225/75R15 P245/60R15 | P255/60R15 | 235/60R16 P225/55R16 225/60R17 6.50-16LT P235/55R17 215/60R17 P215/65R17 215/55/18 1553 |
| | | P235/65R15 P235/70R15 | P275/50R15 | 215/75R16 225/55R18 235/65R16 225/60R18 235/55R18 245/452R19 1555 |



McGEE COMPANY

Denver (HDQTR)
1140 South Jason St.
Denver, CO 80223
(800) 525-8888
(303) 777-2615
FAX (303) 777-7140

Salt Lake City
1101 S. 700 West
Salt Lake City, UT 84104
(800) 525-8888
(801) 487-8751
FAX (801) 487-8753

Albuquerque
4412 Prospect NE
Albuquerque, NM 87110
(800) 525-8888
(505) 883-9613
FAX (505) 883-1382

Dallas
8504 Chancellor Row
Dallas, TX 75427
(800) 525-8888
(214) 689-0400
FAX (214) 689-0448

TIRE CHAINS

Largest Stock of tire chains in the Rocky Mountain Area!

Laclede™ Tire Chains

| TIRE SIZES | | | | Stock Number | |
|---------------|-----------------|-----------------|-------------|--------------|-------|
| Single mount | | Dual Mount | | | |
| 8.25-15LT | P265/75R16 | 255/60R17 | 245/70R17.5 | 3210R | |
| 10-15LT | 245/85R16LT | P255/70R17 | P255/70R18 | | |
| 265/70R15LT | 265/70R16LT | P265/65R17 | 275/55R18 | | |
| 265/75R15LT | 265/75R16LT | P265/70R17 | P275/60R18 | | |
| 305/50R15 | 265/80R16LT | 265/70R17LT | 225/70R19.5 | | |
| 31X10.50-15LT | 275/70R16LT | 275/65R17 | 245/70R19.5 | | |
| 33X10.50-15 | 295/50R16LT | 235/75R17.5 | P265/65R18 | | |
| P265/70R16 | 245/75R17LT | | 255/70R18 | | |
| PR78-15 | PR78-16 | 34X9-16 | 285/65R18LT | | 3227R |
| 11-15LT | 12-16.5LT | 31X10.50-16.5LT | 285/45R19 | | |
| 31X11.50-15LT | P285/60R16 | 285/60R17 | 275/60R20 | | |
| 32X11.50-15LT | 275/65R16LT | 285/70R17 | P285/50R20 | | |
| 33X9.50-15LT | 285/60R16LT | 305/45R17 | | | |
| 33X13.50-15 | 32X11.50-16LT | P265/60R18 | | | |
| 34X9.50-15LT | 33X13.50-16 | 285/60R18 | | | |
| 285/75R16LT | 265/70R18 | 275/70R18LT | | | |
| 31X12.50-16 | 275/65R18 | | | | |
| 12-15LT | 11L16 | 33X15.5-16.5 | 275/65R20LT | 3229R | |
| P315/70R15 | 285/70R16LT | 275/70R17 | 305/50R20 | | |
| 325/60R15 | 295/75R16LT | 285/75R17LT | 305/55R20 | | |
| 31X13.5-15 | 305/70R16LT | 295/70R17LT | 285/50R22 | | |
| 32X12.50-15 | 305/85R16LT | 305/70R17 | 33X11.5-22 | | |
| 33X12.50R15 | 35X12.5-16 | 33X12.50-17 | 285/55R20LT | | |
| 33X14-15 | 35X13.5-16 | 10.50/80R18 | 32X11.50-20 | | |
| 33X14.50-15 | 36X13-16 | 285/75R18LT | 275/70R18 | | |
| 35X12.50-15 | 32X12.50-16.5LT | 325/60R18 | 295/70R18 | | |
| 35X14.5-15 | 33X12.5-16.5 | 33X13-18 | | | |
| QR78-15 | 38X13-16 | 345/55R17 | 325/65R18 | 3231R | |
| 35X13.5-15 | 35X12.50-16.5 | 35X12.50-17 | 35X12.50-20 | | |
| 37X13-15 | 38X12.50-16.5 | 37X12.50-17 | 325/50R22LT | | |
| 345/55R16LT | 315/70R17LT | 305/60R18 | 35X12.5-22 | | |
| 37X12.50-16 | 325/70R17 | 305/70R18LT | | | |
| 35X14-15 | 35X14-16 | 37X12.5-16.5 | 37X13.5-17 | 3235R | |
| 36X12.50-15 | 36X12.5-16.5 | 38X15.5-16.5 | 14-17.5 | | |
| 37X13.50-15 | 36X14-16.5 | 355/70R17LT | 285/70R19.5 | | |
| 37x14.50-15 | 38x14.50-16 | 40X17-16.5 | 37x13.50-22 | 3251R | |
| 39.5X15-15 | 325/80R16 | 355/65R18 | | | |
| 40X17-15 | 39.5X15-16.5 | 37x13.50-20 | | | |
| 355/80R20 | 13-22.5 | 15-22.5 | 385/65R22.5 | 3255R | |
| 42X15-16.5 | 38X13.5-20 | 335/80R-18 | 7.00-18 | 3259R | |
| 355/60R20 | | | 6.50-20 | | |
| 18-22.5 | 445/65R22.5 | | 8-19.5 | 7-22.5 | |
| 38.5X16-15 | 39.5X15-16 | 39.5X18-16.5 | 15-19.5 | 7.50-17 | |
| 39.5X18-15 | 38.5X16-16 | 38X15.5-18 | 38X15.50-20 | 7.00-20 | |
| 445/50R22.5 | 455/55R22.5 | | | 3269R | |
| 445/65R19.5 | 16.5-22.5 | 425/65R22.5 | | 3271R | |



Wide Base Truck Cam Chains

Dual Truck Chains

DUO Tractor Chains

| Tire Sizes | | | | | Stock No. |
|------------|------------|-----------|-----------|-----------|-----------|
| 9.5-24 | 9.5-28 | 11.2-24 | | | DUO214 |
| 9.5-32 | 11.2-28 | 230/95R32 | 355/80R20 | | DUO226 |
| 10.5/80-18 | 12-16.5 | 280/70R20 | 300/70R20 | 315/75D15 | DUO225 |
| 12.4-24 | | | | | DUO229 |
| 9.5-36 | 9.5-38 | 11.2-32 | 12.4-28 | | DUO218 |
| 13.9-36 | 320/85R34 | | | | DUO242 |
| 13.6-24 | 13.6-26 | 14.9-24 | | | DUO240 |
| 14.9-26 | | | | | DUO250 |
| 14.9-28 | 14.9-30 | | | | DUO252 |
| 13.6-28 | 16.9-24 | 320/85R38 | 340/85R28 | 380/85R34 | DUO260 |
| 14.9-38 | 15.5-38 | 320/90R46 | | | DUO254 |
| 17.5-24 | 17.5L-24 | | | | DUO263 |
| 16.9-26 | 16.9-28 | 420/85R28 | | | DUO262 |
| 16.9-32 | | | | | DUO266 |
| 16.9-34 | 230/95R44 | | | | DUO270 |
| 18.4-16.1 | 21.5L-16.1 | | | | DUO264 |
| 18.4-24 | 19.5L-24 | | | | DUO268 |
| 16.9-30 | 18.4-26 | 18.4-28 | 18.4-30 | 540/65R30 | |
| 550/65R25 | 600/65R28 | | | | DUO271 |
| 18.4-34 | 480/85R34 | 600/65R25 | | | DUO273 |
| 16.9-38 | 18.4-38 | 20.8-34 | 380/90R50 | 420/80R46 | |
| 460/85R34 | 480/80R38 | | | | DUO272 |
| 18.4-42 | 18.4-46 | 380/90R54 | 480/80R46 | | DUO277 |
| 20.8-38 | | | | | DUO276 |
| 24.5-32 | 23.1-34 | 28.1-34 | 620/70R42 | 650/75R32 | DUO282 |

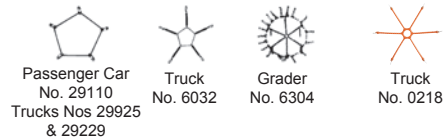

Tire Chain Adjusters

| Ascot No. | Mfg. No. | Description | Qty. |
|-----------|----------|-------------------------|----------------------|
| 458-29110 | 29110 | Passenger Car - Rubber | 2 per bag |
| 458-29225 | 29225 | Light Truck - Rubber | 2 per bag |
| 458-29229 | 29229 | Heavy Truck - Rubber | 2 per bag |
| | 0218 | Spider Truck | 2 per bag |
| 458-06302 | 6302 | Light Truck - Spring | 1 pair per container |
| 458-06304 | 6304 | Tractor/Grader - Spring | 1 pair per container |

LG Cam Series Available



| Tire Sizes | | | Tire Chain Stock No. |
|-------------|-------------|-----------|----------------------|
| 13.00-24/25 | 14.00-20/21 | 15.5-25 | 2612 |
| 14.00-24 | 14.00-25 | | 2615 |
| 16.00-20/21 | 17.5-25 | | 2624 |
| 16.00-24 | 16.00-25 | | 2627 |
| 20.5-25 | | | 2633 |
| 18.00-25 | 18.00-24 | 18.00-26 | 2636 |
| 18.00-33 | | | 2642 |
| 23.5-25 | | | 2645 |
| 26.5-25 | 755/70R25 | 30.5R32 | 2657 |
| 710/70R38 | | 800/65R32 | |

1/2" Drive Super Duty Air Impact Wrench

- 2" extended anvil
- Handle exhaust
- Free speed: 8000 RPM
- Maximum torque: 600 ft./lbs.
- Proven design and the most popular configuration in the tire service industry
- Powered by the durable and high performing twin hammer mechanism
- Net weight: 5.6 lbs.



153-23120

\$119.95

| Ascot No. | McGee No. | Description |
|-----------|-----------|--|
| 153-23120 | 15323120 | 1/2" Drive Air Impact Wrench - 2" Extended Anvil |

1/2" Drive Composite Impact Wrench

- 2" extended anvil
- Handle exhaust
- 700 ft./lbs. of torque
- Free speed: 8000 RPM
- Composite body offering lighter weight and improved balance
- Powered by the durable and high performing twin hammer mechanism
- Handle exhaust
- Net weight: 4.9 lbs.



153-12131

| Ascot No. | McGee No. | Description | Price |
|-----------|-----------|--|-----------------|
| 153-12131 | 15312131 | 1/2" Drive Composite Impact Wrench 2" Extended Anvil | \$154.95 |

1/2" Drive Mini Air Impact Wrench

- 2" extended anvil
- Handle exhaust
- Under 4 lbs. • 500 ft./lbs. of torque
- Smallest and lightest 1/2" in the tire service industry
- Powered by the extremely durable jumbo hammer mechanism



153-12646

\$149.95

| Ascot No. | McGee No. | Description |
|-----------|-----------|---|
| 153-12646 | 15312646 | 1/2" Drive Mini Air Impact Wrench - 2" Extended Anvil |

1" Drive Mini Air Impact Wrench

- 6" Extended Anvil
- Free speed: 5500 RPM
- Maximum torque: 1600 ft/lbs
- Only 14.77 lbs – 50% less than the market leading 1" product
- Smallest and lightest 1" in the tire service industry
- Powered by the durable pinless clutch that is the industry standard for 1" impacts

\$459.95



155-16464

| Ascot No. | McGee No. | Description |
|-----------|-----------|---|
| 155-16464 | 15516464 | 1" Drive Mini Air Impact Wrench - 6" Extended Anvil |

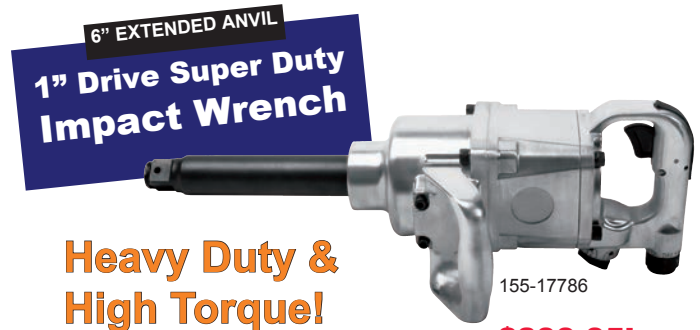

Heavy Duty & High Torque!

155-17786

\$399.95!

1. DURABLE: Steel end plates offering durability and extended life
2. ADVANCED DESIGN: Proven motor and hammer technology; highly efficient air motor
3. WORKING TORQUE RANGE: 370-1475 ft./lbs.
4. 1 YEAR LIMITED WARRANTY on parts and workmanship
5. COMPARE to CP77826

| McGee # | Sq. Drive | Std. Bolt Size | Net Weight (lbs.) | Average Air Cons (cfm) | Air Inlet (NPTF) | Min. Hose Size | Working Torque Range ft.-lbs. | Max Torque ft.-lbs. |
|----------|-----------|----------------|-------------------|------------------------|------------------|----------------|-------------------------------|---------------------|
| 15517786 | 1" | 1-1/4" | 25.55 | 10 CFM | 1/2" | 1/2" | 370-1475 | 1920 |

15617786 – Spline dr version - **\$439.95**

Free 6 pack cooler with purchase of any Ascot tool on this page!



#B6PC

*Call today
1-800-525-8888*

153-02312 231XP2



1/2" Super Duty Extended Anvil Air Impact Wrench

This new model redefines the standards set by the classic IR231 model, with an enhanced Twin Hammer impact mechanism for more power and in-handle exhaust to direct air away from the operator and the work area.



\$139.95

3/4" Super Duty Air Impact Wrench

- Powerful 3/4" wrench • Combines compact size with high output • Ideal for everything from spring work to pinion nut and track pad removal and major engine teardowns
- Jumbo hammer mechanism delivers up to 1,100 ft./lbs. of torque smoothly, with less vibration

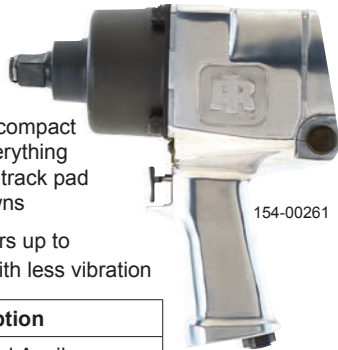

154-00261

| Ascot No. | McGee No. | Description |
|-----------|-----------|-------------------|
| 154-00261 | IR261 | Standard Anvil |
| 154-02616 | IR2616 | 6" Extended Anvil |

\$448.00

1" Heavy Duty Air Impact Wrench

155-02856

Perfect for the demanding world of truck tire and service work

- Combines exceptional power, durability and operator convenience
- Delivers 1450 ft./lbs. of maximum torque, with a 5000 RPM free speed and four-position power regulator 360° swivel inlet
- Available in 6" extended anvil and 6" extended #5 spline drive anvil for high production truck tire changing

| Ascot No. | McGee. No. | Description | Price |
|-----------|------------|----------------------------|-----------------|
| 155-28560 | IR-285B | Standard Anvil | \$469.95 |
| 155-02856 | IR-285B6 | 6" Extended Anvil | \$469.95 |
| 156-28566 | IR-285BS6 | #5 Spline Super Duty Anvil | \$539.95 |

1" Heavy Duty Air Impact Wrench

2140 ft.lbs 2900 Nm of maximum torque in reverse

- Pinless closed reinforced rocking dog impact mechanism
- Socket retainer ring combined with hole retainer
- Ergonomic side handle
- Full teasing trigger
- Regulator with integrated forward/reverse with 3-position power
- settings in both directions

1/2" CP7748 - Extreme torque & durability

FEATURES

- Most powerful 1/2" air wrench in its class
- Twin hammer grease clutch
- Ergonomic rubber handle
- Reinforced nose wings and back housing cap for longer durability
- Max Torque 1200 ft. lbs.
- 922 ft. lbs. Working Torque



CP77482 - \$169.95

1" Heavy Duty Air Impact Wrench

- High performance clutch provides longer life under tough conditions
- High-efficiency 6 vane motor for maximum performance
- Bottom exhaust directs exhaust away from the operator
- Three position power regulator with directional control
- Ultimate Torque: 1,450 ft./lbs.



155-77786

| ASCOT NO. | McGEE NO. | DESCRIPTION | PRICE |
|-----------|-----------|----------------------------------|-----------------|
| 155-77786 | CP77786 | 6" Extended Anvil | \$587.95 |
| 155-27786 | CP7778SP6 | #5 Spline with 6" Extended Anvil | \$599.95 |

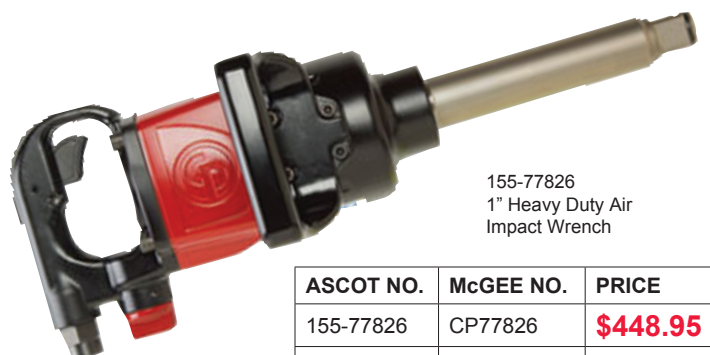

155-77826
1" Heavy Duty Air
Impact Wrench

| ASCOT NO. | McGEE NO. | PRICE |
|-----------|-----------|-----------------|
| 155-77826 | CP77826 | \$448.95 |
| 155-17782 | CP7782SP | \$509.95 |

ADHESIVE WHEEL WEIGHTS

| | | | | | | | | |
|--------------------------|-----------|---------|---|-------------|---------------|----------------------------|-------------------|-----------------------------------|
| | 7026 | .25 oz. | Low Profile Premium Tape | | 48 strips/box | Width: 3/4" Depth: 1/8" | Lead 576 seg/box | Special! \$24.95 |
| Black | 7026FEB | .25 oz. | Tape-On-Top Low Profile Premium Tape Black Polycoat | 2 oz./strip | 30 strips/box | Width: 3/4" Depth: 1/8" | Steel 240 Seg/box | Special! \$39.95 |
| Bracket Not Included | 7026FER | .25 oz. | Bulk Roll Premium Tape Polycoat | Bulk Roll | 1 strip/box | Width: 3/4" Depth: 1/8" | Steel 700 seg/box | Special! \$44.95 |
| | 200576 | .25 oz. | Low Profile Coated | | 52 strips/box | Width: 3/4" Depth: 1/8" | Lead 576 pcs | Special! \$19.95 |
| Plombco Style | WR31252CW | .25 oz. | Cold Weather Tape | | 52 strips/box | Width: 3/4" Depth: 1/8" | Lead 624 pcs | \$64.95 |
| Peeling off strip | 100720 | .25 oz. | Standard Profile Quick Tab with Premium Tape | | 60 strips/box | Width: 3/4" Depth: 1/8" | Lead 720 pcs | \$59.95 |
| | 300360 | .50 oz. | Standard Profile Quick Tab with Premium Tape | | 30 strips/box | Width: 1" | Lead 360 pcs | \$49.95 |
| | CL6 | 1 oz. | Standard Profile Quick Tab with Premium Tape | | 30 strips/box | width 3/4" | Lead 180 pcs | \$50.00 |
| | CL12 | 2 oz. | Standard Profile Quick Tab with Premium Tape | | 8 strips/box | width 1-1/4" | Lead 48 pcs. | \$33.00 |
| | 300360 | .50 oz. | Standard Profile Quick Tab with Premium Tape | | 30 strips/box | Width: 1" | Lead 360 pcs | \$49.95 |
| | 300360ST | .50 oz. | Standard Profile Quick Tab with Premium Tape | | 30 strips/box | Width: 1" | Steel 360 pcs | Call! |

Wheel Cleaner

Stop Using Expensive Wheel Cleaning Solutions

A clean wheel is critical to good stick-on wheel weight adhesive.

- Water-Based
- Biodegradable
- Non-Petroleum
- Non-Toxic

| Ascot No. | Description | Price |
|-----------|-----------------------------------|----------------|
| 48675032 | Wheel Cleaner 32 Oz. Spray Bottle | \$9.00 |
| 48675017 | Wheel Cleaner 1 Gallon Bottle | \$15.95 |



A Note About Today's Wheels

For environmental reasons the car manufacturers recently started using water-based paint on wheels. Unfortunately, those paints have an adverse effect on the adherence of wheel weights. The special formulation assures optimal adherence even on surfaces coated with water-based paint.

Premium Fiberglass WHEEL WEIGHT HAMMER BEST IN CLASS

- Fiberglass Shaft for Added Durability
- Easy to Use!
- Heavy Duty Chromally Hook
- Slip-Resistant Ergonomic Grip
- Standard Large Replaceable Hook
- Replaceable Tip



486-11000 Premium Fiberglass Wheel Weight Hammer

ACCESSORIES



486-11005 Replacement Tip



486-11005 Replacement Large End



3358 486-33580



Scraper 71510 486-071510

- 486-71510** 71510 Adhesive Wheel Weight Super Scraper Removes emblems, body side moldings and stick-on wheel weights. **\$14.95**
- 486-33580** 3358 KD/Bada Premium Weight Tool - Ideal for all weights, including coated..... **\$24.95**
- 48611000** Premium tool with replaceable hook (486-11005)..... **\$29.95**



WHEEL WEIGHTS



Professional Wheel Weight Kit

This kit contains a wide assortment of seven styles of polyester-coated wheel weights plus regular weights for steel wheels. The pre-labeled, color-coded bins are supported on a free standing floor display with descriptive header. This kit includes 74 pre-labeled, color-coded bins, over 2000 wheel weights, coated wheel weight installation/removal tool, application chart, and alloy wheel gauge. The Kit 2250 Professional covers 95% of today's balancing needs.

Contents

2100 wheel weights, 50 of each size for regular weights (REG), 25 of each for polyester-coated weights, installation/removal tool (WR 305-25 PC), application chart, application hand gauge, header, 74 plastic bins, 1 metal floor stand.

KIT2250

\$949.95

MC Series fits more U.S. vehicles than any other weight!

"MCN" Series- Wheel Protectors® Coated

The "MCN" series is the recommended weight for all applications shown below. The "MCN" meets all OEM quality specifications.

"MC" Series-Uncoated

Fits most Chrysler, GM, Ford since 1990

We recommend that coated weights be used on all vehicles having alloy wheels.

"MCN" Coated—25 pc. box. "MC" Uncoated—50 pc. box

MC



| | |
|---------|------------------------|
| AUDI | JAGUAR |
| BMW | KIA |
| CATERA | MITSUBISHI (see chart) |
| GEO | SUBARU |
| HYUNDAI | SUZUKI |
| | VOLVO |
| | MINI |
| | LAND ROVER |



IAW



5 to 60 g

| | |
|----------|-----------------------|
| AUDI | From 1997 |
| HONDA | |
| & ACURA | All from 1980 to 1989 |
| MERCEDES | |
| VW | |



Also used on many after-market alloy wheels with thin rim flanges

EN



10 to 60 g

Promote Rotating and Balancing

- Improve vehicle ride and extend tire life
- An opportunity to sell an additional profitable service

Call for free balancing tip brochure and application chart.

Ask your McGee representative!

| | | |
|-----------|--|-------------|
| CHEVROLET | Use on full size pickup, Suburban. | <h1>TS</h1> |
| GMC | Yukon, Tahoe from 2000. Denali & Escalade use MCS for 2000. | |
| FORD | Expedition from 1997 F-100, F-150 from 1997 | |
| LINCOLN | Navigator from 1998 | |

We recommend the use of TS series weights on all full size pickup trucks and vans equipped with steel wheels.

The use of "REG" series passenger weights on thicker truck rims may cause over-stressing of clips resulting in weight failures.



1/4 oz to 3 oz

| | | |
|----------|-----------------|-------------|
| ACURA | Most since 1990 | <h1>FN</h1> |
| DAEWOO | All since 1999 | |
| HONDA | All since 1989 | |
| INFINITI | All since 1990 | |
| ISUZU | All since 1997 | |
| LEXUS | All since 1990 | |
| MAZDA | Many since 1990 | |
| NISSAN | All since 1990 | |
| TOYOTA | All since 1990 | |



5 to 70 g

Complete Stock of Passenger and Truck Weights!

See chart for exceptions

Copy-cat TPMS parts are a ticking time bomb



Here's why you should avoid TPMS parts that haven't been OE engineered and validated to meet the requirements set by NHTSA.

As TPMS is a safety system, failure to properly and safely maintain it puts your customers' safety at risk — and puts you in danger of legal action that could ruin your shop.

Unlike many competitors, all VDO TPMS products use only OE-validated parts that meet the functional requirements set by NHTSA in FMVSS No. 138. From the valve cores to the full

sensor assemblies, all VDO TPMS Replacement Parts go through the stringent OE-validation procedures that apply to all parts we sell to both automakers and the aftermarket.

REDI-Sensor™

BUILT TO DELIVER LONG-LIFE RELIABILITY:



Redi-Sensor Universal Transmitter

- Installs right out of the box
- No programming required
- Reduces replacement sensor inventory
- Adjustable valve stem design

Redi-Sensor
\$36.95 ea!

7001 & 7004 sensors cover over 90% of GM, Ford, Chrysler, Mazda, Suzuki, and Mitsubishi

7002: Fits popular Honda, Hyundai, Kia, Lexus, Scion, Toyota and other Asian vehicles

New! 7003: Fits popular VW, Mercedes, Audi, Lexus, Volvo, Toyota, Infiniti, Nissan, Chevy, GMC, Hummer, Isuzu, and Subaru.

Visit WWW.MCGEECOMPANY.COM resource page for latest TPMS application guide!

- 46107001 - Redi-Sensor 315 MHz (7001HP)
- 46107011 - Redi-Sensor with rubber stem 315 MHz (7001HPR)
- 46107003 - Redi-Sensors 315MHz (7003)
- 46107004 - Redi-Sensor 433 MHz (7004)
- 46107002 - Redi-Sensor 315 MHz (7002)

Call Today
1(800)525-8888

(Use 7020K Kit to repair Redi-Sensor)

REDI-Sensor™

WORKS WITH EXISTING MAJOR TPMS SCAN TOOLS:



If a shop has the tools to handle OE sensors, it's ready for REDI-Sensor. Unlike other sensors that require the purchase of specialized tools and software upgrades, no additional purchases, training or investments are needed with REDI-Sensor.

It works with all major TPMS scan tools, including ATEQ, Bartec, OTC and T.I.P.S. With REDI-Sensor, technicians can use the OE scan tool procedures for TPMS service – no new service routines are required.

THE INDUSTRY SAYS, "REPLACE SERVICE KITS."

Every major car manufacturer and the Rubber Manufacturers Association recommend replacing the TPMS service kit or valve stem when dismantling the tire.

7100 TPMS Accessory Kit Assortment provides 95% kit coverage!

Contains 78 kits and 4 chrome sleeves

7100 Kit **\$129.95**



Reusing seals or using inferior seals = slow leaks



Reusing hex nuts or using inferior nuts = corrosion and a damaged sensor!



Unplated Valve Core, Corroded in Stem (valve core will not actuate)

Must replace grommet



TPMS ACCESSORIES

TPMS Valve Core - OE

Electroless Nickel-Plated • Valve Core - 100 per box



| Ascot No. | McGee No. | Price |
|-----------|-----------|----------------|
| 468-20055 | SH20055 | \$11.95 |



**Now in stock!
Valve Cores**

**New TPMS
Catalog and
Application Chart**

Bartec Mechanical Tool Kit

- Valve Core Torque Driver
- T-10 Torque Driver
- T-20 Torque Driver
- 3-Way Fishing Tool
- Grommet Tool
- Torque Wrench
- TPMS Toyota Reset Tool



\$169.57

All fitted in a plastic case

| Ascot No. | McGee No. | Description |
|-----------|-----------|----------------------------|
| 469-10300 | WRTMT104 | Bartec Mechanical Tool Kit |

TPMS Consumer Kit

Background: Bartec understands that being able to sell TPMS is directly related to being able to explain TPMS. Our "Talking TPMS" program is geared to help tire technicians and service writers give their customers the right information about PROPER TPMS service and maintenance, in an effort to make selling and serving TPMS easier and more profitable! - WRTCNK001

Kit includes:

- Informative counter mat
- "How TPMS Works" tri-fold (50 pcs)
- "What Every Consumer Should Know" tri-fold (50 pcs)
- Tri-fold counter top display
- Mouse pad
- 2' x 3' wall or window poster
- 2' x 8' hanging window banner
- Talking TPMS reference book

\$150.00



| McGee No. | Description |
|-----------|-------------------|
| WRTCNK001 | TPMS Consumer Kit |

Valve Core Torque Tool - easy to use handle

Preset torque guarantees correct setting every time on all cores!

- Calibrated to 4 in/lbs of torque
- Meets the Tire & Rim Association (TRA) specifications for installing valve cores on TPMS applications
- Can be used to install and remove cores in standard valve stems

| Ascot No. | McGee No. | Price |
|-----------|-----------|----------------|
| 46900044 | 46900044 | \$15.85 |



TPMS Valve Caps

Steel or brass caps will freeze to aluminum sensors



Plastic



Aluminum



| Ascot No. | McGee No. | Description | Price per 100 |
|-----------|-----------|------------------------------|----------------|
| 468-00050 | SH00050 | Gray Plastic Cap | \$11.95 |
| 468-20495 | SH20495 | Aluminum Cap | \$21.95 |
| 468-00635 | 635 | OE Black Cap TPMS Snap-In | \$21.95 |
| 468-17492 | 46817492 | China Black Cap TPMS Snap-In | \$5.95 |

TPMS Counter Display

Rubber seal is 100% EPDM and needs to be replaced because heat, cold, moisture, oils, ozone, plus constant compression in the rim hole can lead to slow leaks of air from your tire.

Cap is a gray plastic sealing cap that protects the tire from leaking (?). Be sure to keep these screwed on all 4 of your tires!

Valve Core & Nut are nickel plated to protect from corrosion while transmitting signal strength to your onboard computer.

Unique components must be replaced every time the tire is disassembled



*Educate
your
customers!*

**46961589
\$19.95**

TPMS 4-Way Valve Tool



11mm and 12mm nut tool used to quickly remove TPMS nuts and to reset grommets

#KT171997
\$4.99

30209 - TPMS 3-way fishing tool is designed to keep the sensor in a safe and secure position while dismantling the tire.

\$3.77



Tire Deflator / Valve Core Remover

- Screws on TPMS valve stems to deflate the tire without removing the valve core

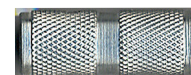

| Ascot No. | McGee No. | Price |
|-----------|-----------|---------------|
| 469-00021 | TL615 | \$.99 |

EZ-sensor™

Programmable Tire Pressure Monitoring Sensor

- Eliminate lost sales
- Optimize inventory levels
- Reduce risk of installing the wrong part
- Increase speed, ensure accuracy, and reduce cost of servicing TPMS equipped vehicles
- Works with Bartec® Tech400, Tech500, or Tech 300SD
- Program a duplicate set of wheels and tires to match the OE vehicle

...Always Have the Right Part, Right Away - Now in Stock!

EZ-sensor advantages:

- Schrader patented technology offers a truly programmable solution with snap-in & clamp-in options
- EZ-sensor performs identically to the original OEM-equivalent
- The EZ-sensor comes blank and is fully programmable to the selected vehicle type
- Initial EZ-sensor (315 MHz) coverage includes specific vehicles for Ford®, Lincoln®, Mercury®, Mazda®, GM®, Toyota®, Lexus®, Scion®, Nissan® and Infiniti® (See EZ-sensor application guide on the McGee website resource page.)
- EZ-sensor (433MHz) coverage includes specific vehicles on leading platforms such as Chrysler®, Dodge®, Ford®, Isuzu®, Jeep®, Lincoln®, and Mercury® (See EZ-sensor application guide)

(These two EZ-to-program snap-in sensors replace approximately 90% of OEM SKUs!)

Order EZ-sensor today. Software updates are now available.



The right PART, the right TOOL



Why EZ-sensor™ Why Tech400?

- ✓ Program EZ-sensors with the same tool used to diagnose and repair the TPMS.
- ✓ Intuitive menu flow for easy programming.
- ✓ Copy sensor ID's directly from car or existing sensor.
- ✓ No TYPING or ENTERING sensor IDs.
- ✓ Create unique sensors, even if the vehicle is not in the bay.
- ✓ Diagnose sensor problem (wrong type, failed battery, etc.) and program a replacement EZsensor™ right in the repair bay!
- ✓ Extract the sensor IDs from the vehicle control module and program them into the EZ-sensor™

Test before you touch!



Program the EZ-sensor™



Finish the repair!



461-33000

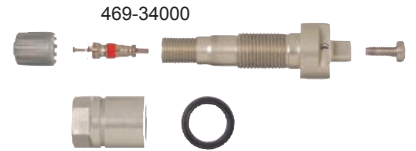

469-34000

\$37.95 ea



461-33200

| ASCOT NO. | McGEE NO. | DESCRIPTION |
|-----------|-----------|---|
| 461-33000 | 46133000 | EZ-Sensor 315 MHz Programmable TPMS Sensor |
| 461-33200 | 46133200 | EZ Sensor 433 MHz Programmble TPMS Sensor w/ Wireless Auto Locate Feature (will replace 46133100) |
| 469-20014 | SH20014AK | Kit for 34000 EZ Alloy Stem |
| 469-20018 | SH20018 | EZ Rubber Stem OE |

TPMS Sensors need to be replaced for many reasons. The most common are:

- Sensor battery is failing or has failed
- Sensor is broken during service
- Sensor is damaged while being driven
- New sensors for additional wheel sets

Solve each of these scenarios with EZ-sensor and the Tech400.

WITH ONE PART AND ONE TOOL!



Tech400+ shown with programming fixture (purchased separately)

POPULAR TPMS KITS AND STEMS

Avoid flat tires! New tires mounted on TPMS equipped vehicles require TPMS replacement kits.

TPMS Accessory Kits — Dill or Schrader - OE Approved

| Ascot No. | McGee No. | Schrader Version | Description | Price |
|-----------|-----------|-----------------------------------|--|----------------|
| 469-01030 | 1030K | SH20017AK | Siemens Kit for VW (Fits 1053 Sensor) (Orange) | \$2.99 |
| 469-01031 | 1031K | SH20017AK | VW Kit for Special Wheel Package (Lt. Green) | \$7.15 |
| 469-01040 | 1040DL | — | Siemens Mercedes Assembled Valve (Brown) | \$8.93 |
| 469-01050 | 1050K | SH20013AK/ SH20030AK | Siemens Kit for Chrysler (White) SH20013AK includes bottom ball | \$2.79 |
| 469-01060 | 1060K | 20001/20002/ 20135AK/20096AK | Fits Schrader SH20096 (Red) | \$1.75 |
| 469-01070 | 1070K | 20004/20116AK/ 20115AK/20107AK | Fits Dill 9076, 9107, 9115, 9116 (Blue) | \$1.75 |
| 469-01080 | 1080K | 20003/20007/ 20117AK/20028AK | Fits Dill 9028, 9034, 9064, 9081, 9117, 9161 (Green) | \$1.75 |
| 469-01090 | 1090K | — | Compatible with Beru Sensors (Grey) | \$3.60 |
| 469-20036 | SH20036AK | — | Entire Valve (Schrader 20036) for Hyundai, Kia, Honda (Dill 1096) | \$7.86 |
| 469-01097 | SH20035AK | — | Entire Valve (Schrader 20035) for Hyundai, Kia, Honda (Dill 1097) | \$10.87 |
| 469-01098 | 1098K | — | Dodge Sprinter Replacement Valve (non-stock) | \$11.46 |
| 469-01100 | 1100K | SH20032AK | Compatible with Pacific Sensors for Toyota/Lexus (Purple) | \$2.95 |
| 469-01110 | 1110K | SH20006AK | Compatible with Pacific Sensors for Toyota (Teal) | \$2.95 |
| 469-11120 | 1120K | SH20032AK | Compatible with Pacific Sensors for Lexus (Gold) | \$2.95 |
| 469-01130 | 1130K | SH20030AK | Compatible with Schrader 20005 (Burgandy) | \$2.15 |
| 469-20025 | 2000K | — | TRW Kit | \$2.85 |
| 469-20010 | 2010K | SH20015AK | Compatible with Schrader Sensors for Volvo (non-stock) (Lt. Brown) | \$1.64 |
| 469-20020 | 2020K | SH20030AK | Early 2007 GM Kit for Entire Sensors (Pink) | \$1.92 |
| 469-20030 | 2030K | SH20013AK/ SH20016AK | Dill Sensors 9154, 9204, 9214 | \$1.92 |
| 469-02040 | 2040K | SH20019AK | Kit for Honda Civic (Lt. Blue) | \$2.08 |
| 469-02045 | 2045K | — | Kit for Honda & Acura | \$2.03 |
| | VS919 | — | For .625 stem hole, often in 19.5 wheels. For the trailer TPMS | \$16.25 |
| 469-09250 | VS925A | — | Aluminum Metal Replacement Valve for GM Snap-In | \$3.63 |
| | VS925C | — | Chrome Metal Replacement Valve for GM and Ford Snap-In | \$3.74 |
| 469-00950 | VS950 | SH20018 | Rubber Snap-In Replacement Valve for GM & Ford Transmitters. (ea) | \$1.86 |
| 469-09305 | VS950SC | — | Chrome Replacement Valve for GM and Ford Snap-In | \$2.50 |
| | SH20020 | — | Replacement Stem Chrysler, Uses Kit 1050K | \$2.07 |
| 469-90660 | 9066K | — | Complete Replacement Stem Chrysler with Kit | \$3.14 |
| | 7020K | — | Accessory Kit for Redi Sensor | \$3.68 |
| 469-00770 | VS70 | — | Available on the following vehicle in various forms: Years 2010 to 2014 (Acura, Cadillac, Chrysler, Dodge, Honda, Hyundai, KIA, Mazda, Nissan) the sensor most associated with the VS-70 is 7001/HP or 7002. | \$4.57 |
| 469-00771 | VS70B | — | Black anodized version of VS-70 | \$7.20 |
| 469-00080 | VS80 | — | Replacement Rubber Stem Kit Dill Redi Sensors | \$3.00 |
| 469-00090 | VS90 | — | Key at base attaches via press clip; Fits Dodge Dart, Mitsubishi Mirage | \$3.81 |
| 469-17208 | 46917208 | — | Rubber Snap-in replacement valve for GM & Ford (not OE certified) China | \$.99 |
| 469-17436 | 46917436 | — | Smart Sensor Snap-In Valve for ITM, Cub, 31Inc, Pilot | \$5.00 |
| 469-20014 | SH20014AK | — | Kit Fits EZ Sensor 34000 Stem | \$2.25 |
| | VS1010 | — | Fits Hyundai Sante Fe Snap-In 7mm | \$2.10 |
| | VS65 | — | Base of stem is square Snap-In Fits Doge Rams, Jeep Cherokee | \$2.36 |



SH20036AK



SH20035AK



VS919



VS925A



VS925C



469-00950



SH20020



VS70



VS80

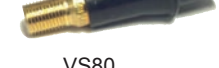

VS90



469-17436

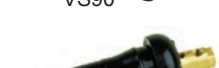

VS1010

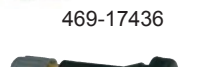

VS65



TECH 400 SD

TPMS All-In-One Tool

FEATURES:

- Large display and key pad
- Re-learn procedures on the tool
- Decodes critical sensor output like PSI, temperature and battery
- Make, Model, Year look up
- TPMS activation and scan tool in one package
- Removable SD card
- Bartec TPMS Audit Mode



A Capture Sensor ID

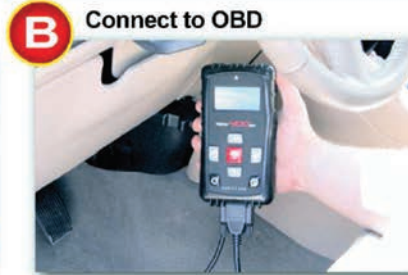

B Connect to OBD



C Program Sensor IDs

- TPMS trouble code detection
- Long life rechargeable battery
- Easily connects to a computer without software

- Rugged design ideal for repair shops
- Integrated OBD technology
- One piece OBD cable
- UHF signal detection

- **RE-LEARN PROCEDURES**
- **VEHICLE PROGRAMMING**

Bartec 400 & 500 Tool

A McGee representative will train your technicians on the basics. Eliminate the need to send vehicles to the dealer for TPMS reset.

Call now for demo and price! 1-800-525-8888

Keep TPMS "In-House" with the unique features on the Tech400SD!

Update without a computer or the internet!



Re-Learn procedures right on the tool, at your finger tips!

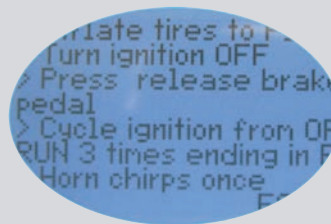

Raised key touch pad for easier operation!



TPMS Programming Accessory Device (Pad)

- Make-Model-Year look up (MMS)
- 2013 Model Year Coverage
- Easy to use software
- Internet is NOT required
- Direct reading from sensor for quick programming
- Connects to PC or LAPTOP using the standard USB cable
- Ideal for busy shops, frees up your TPMS activation tool
- No Batteries are required
- No need to key in the TPMS ID
- No need to type in the VIN



469-50001

Bartec Tech 500 All-In-One TPMS Service Tool w/ OBD and Wireless Connectivity

- Improved hardware performance
- WLAN and Bluetooth wireless communication
- More on-board DTC information
- New easier-to-use menu flow
- New ergonomic enclosure
- Model year 2013 coverage
- Comprehensive audit report
- Extensive OBD coverage, including GM and Ford
- More intuitive operation: ANYONE in your shop can operate this tool
- More TPMS information: All right there in the palm of your hand
- More ergonomic: Easier to operate single-handed
- Wireless communication:
- No USB connection to PC required



469-5000



The Bartec Tech 500 All-In-One TPMS Service Tool in use.

Visit WWW.MCGEECOMPANY.COM resource page for latest TPMS application guide!

| ASCOT NO. | McGee NO. | DESCRIPTION |
|-----------|-----------|--|
| 469-50000 | WRT500 | Tech 500 All-In-One TPMS Service Tool w/ OBD and Wireless Connectivity |

TRUCK TIRE BALANCING

Counteract is the only tire balancing product proven to improve fuel economy in two separate SAE and TMC Type II fuel tests.

All other methods that have tried have failed.



Balance the Whole Truck Wheel Assembly

TIB10 - 10 oz. drop in bag - \$9.95! - Counteract

- Perfect balance - perfect wear
- Clean, trouble free balancing micro-beads provide continuous self-adjusting balance
- Just open the outside package and throw the inside bag into the tire
- Method allows the use of an air blaster to seat the tire on the rim without contaminating the seating area
- Air blaster pressure inside the tire will collapse the bag containing Counteract Balancing Beads or the package will break open and release its contents soon after driving
- Available in application sizes from passenger vehicles to heavy trucks
- All packaging is color coded to tire size on application chart

EQUAL Tire Balancing

EQUAL is always balancing and always dampening, resulting in extended tire life for fleets. By using EQUAL in all wheel positions, it not only balances the entire tire and wheel assembly but also deflects load forces that cause irregular wear for all tires. EQUAL's drop-in-bag makes it easy to reduce balancing related down-time for fleet maintenance savings but also makes balancing drive and trailer tires practical. Extended tire life in the drive and trail positions provides an optimal return on investment.

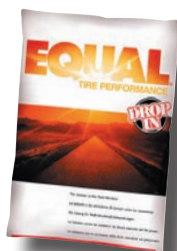

Fast installation with "Drop-In" bag

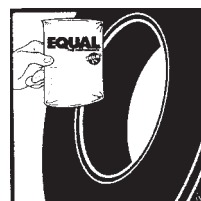

Take an unmounted tire, drop in the new EQUAL bag and mount the tire. The bag breaks apart inside the tire for a clean application. Use the Portable Applicator for on-the-vehicle installation.

Packaged and sold in a case of 40, including 40 filter cores per case

EQUAL

MORE TIRE LESS FUEL

As a tire's tread wears down, its fuel efficiency improves by decreasing rolling resistance. In fact, the last 20 percent of a tire's tread uses 6.5 percent less fuel than new tread. The most effective way to lower fuel costs is by balancing your fleet's tires — because balanced tires wear evenly and last longer.

A balanced tire is also far less prone to vibration. Less vibration means longer tire life, less wear-and-tear on the truck and improved driver comfort. Balanced tires need to be replaced less often, saving money and keeping your drivers on the road longer.

How it does what it does

EQUAL is a patented dry, granular polymer that balances tires from the inside. Simply drop a bag of EQUAL in a tire and it goes to work immediately. With each tire rotation, EQUAL balances the tire and dampens vibration. It self-adjusts based on wear, road conditions and load weight — and requires zero upkeep. Research shows that fleets using EQUAL in their tires achieve tire and fuel savings of \$3,000 to \$7,000 per truck — each year.

Equal Balancing Compound

BALANCE TRUCK TIRES FROM THE INSIDE OUT!

EQUAL Tire Balancing Formula is Fast and Easy

- Balance Steer, Drive & Trailer Tires – Steel or Aluminum Rims
- Continuous Balance – Every Tire, Every Wheel Position, Every Time!
- No More Vibration & Uneven Treadwear

It's common knowledge that a balanced part runs more smoothly, which is why almost every rotating piece on a truck comes balanced from the factory. The one exception: Tires. At 66 mph, just one out

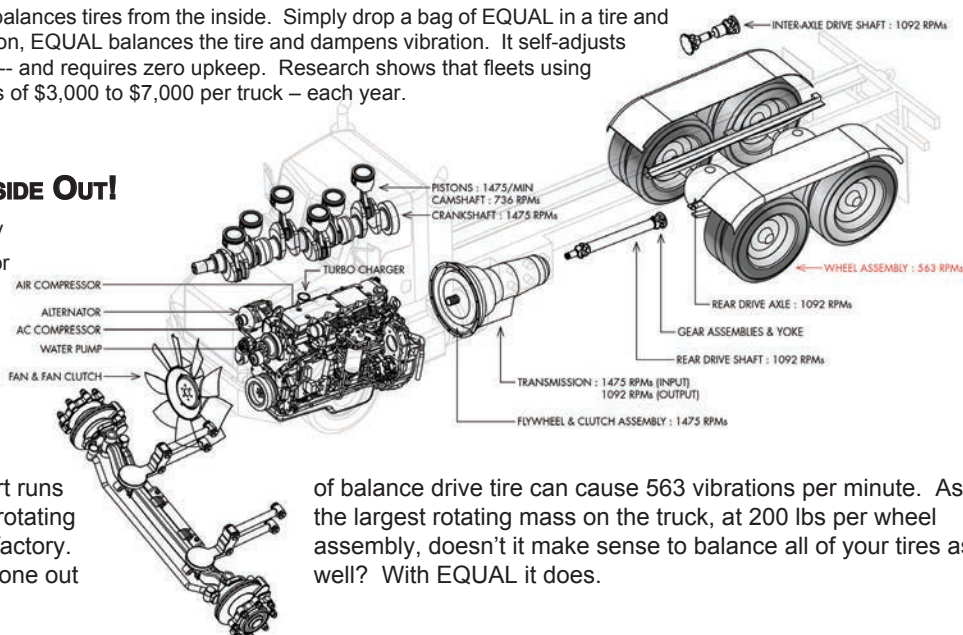

of balance drive tire can cause 563 vibrations per minute. As the largest rotating mass on the truck, at 200 lbs per wheel assembly, doesn't it make sense to balance all of your tires as well? With EQUAL it does.

If it rotates it should be balanced.

WHEEL MOUNTING PROCEDURES

Introducing the Tire Toolz Stud and Wheel Surface Cleaning System

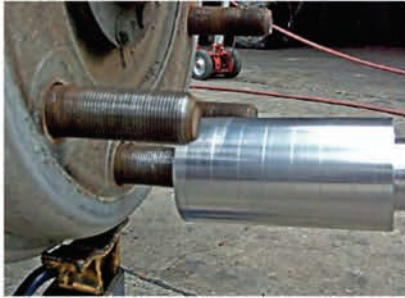

\$149.00
SC100

Tire Toolz
SC100 Stud Cleaner
Do it Right ... Do it Once ... With Tire Toolz



Application:
22mm Uni-Mount Studs
3/4"-16 Budd Studs

The SC100 stud cleaner quickly and easily removes rust, road grime and foreign particles from wheel studs. Three carbon steel brushes engage the full thread and provide a clean surface for the wheel retaining nut allowing an accurate final torque.

Clean Wheel and Attaching Components



Wheel Openings and Pilot Pads



Wheel Nut and Flanges



Wheel Mating Surfaces



Hub and Brake Drum Face

Inspect all Components for Wear and Damage

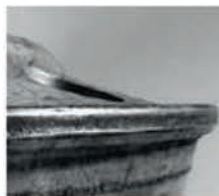
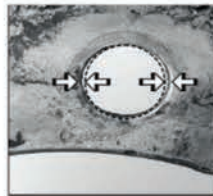
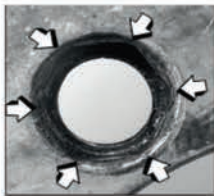

Pre-Torque Wheel Nuts to 65 ft lbs

Rotate Wheel Mount Pad to 12 o'clock



75520 65# torque limiting extension

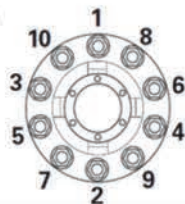

2215TPG \$12.95
22x1.4mm Thread Pitch Gauge for Uni-Mount Studs



New Stud



Worn Stud

Tighten Wheel Nuts to Final Torque



4AR1 Break Back Torque Wrench



47501 475 ft lb Pre-Set Torque Wrench

NEW OSHA 29 CFR 1910.177 wheel mounting procedure manual and charts. These are required by OSHA to be displayed in truck tire service areas or carried in road service trucks \$5.95 each. One FREE with Torque wrench, Torque Set or Stud Cleaner.



WARNING Wheels, studs, nuts and hubs that are not properly installed, inspected or maintained may not be safe. Failure to follow proper installation or maintenance practices may result in injury or death. **Always** use proper personal protection devices for safety and to avoid injury. **ALWAYS FOLLOW GUIDELINES IN OSHA 29 CFR 1910.77 FOR WHEEL MOUNTING**

TRUCK WHEEL SERVICE

Hub-Centric Wheel Nuts - Manufactured in U.S. - High Quality

By filling the void between the stud hole, "clocking" is eliminated, and problems caused by clocking, such as wheel offs and wheel hub vibrations, are eliminated.

- Hub Centric Nut fills void standard flange nuts don't
- Stops rim from shifting forwards or backwards
- Eliminates "clocking" caused by standard wheel nuts not filling wheel hole completely
- Certified American Steel
- Each part tested for thread, fit and finish
- 50 per box

49100133
\$6.95 ea.



Wheel Assembly with Standard Nut

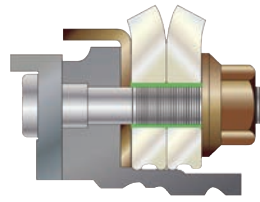

Void (Highlighted in Green) between stud and hole.

Wheel Assembly with Hub Centric Nut

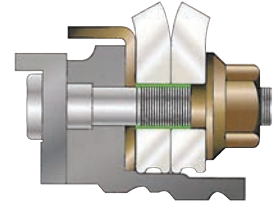

Hub centric nut fills void between stud and hole.

| Ascot No. | Description |
|-----------|-------------------------|
| 491-00133 | 33mm Hex X 1.5mm Thread |



Note marks on the disc (just outside stud hole) caused by "clocking."

This nut had been torqued to specifications and retorqued per factory settings.



1) YELLOW HIGHLIGHT shows void between stud and stud hole.

2) Hub Centric Nut fills void between stud and hole.



Skirt Nut

- Stops wheel/hub vibrations and many tire wearing problems
- Stops wheel movement (clocking) on the face of the hub
- Eliminates wasted fuel caused by rolling resistance or "drag"
- Meets and exceeds standards of SAE J1965 or torque tension
- Replaces all style M22 flange nuts on hub-piloted wheel
- Hex: 33mm
- Special graphite coating prevents nut from rusting onto the hub
- Fills in the gap between the stud and the bolt 3/16" (5mm)
- 50 per box

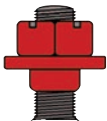

Extended threading allowing Skirt Nut to go down into Hub-Piloted Disc Wheel an extra 3/16" (5mm) into stud hole



MOUNT tire and wheel assembly using a tire dolly to avoid damage to threads and potential back injuries.

Budd Nuts and studs should not be lubricated. TIA recommends: lubricate Hub-Pilot studs and nuts with 2 drops 30w oil before tightening.

New Skirt Nut Sizes!

| Ascot No. | Mfg. No. | Description | Price |
|-----------|--------------------|--|---------------|
| 491-02906 | GL-2906 333SN6 | Haltec 6mm Sleeve Nut • Steel Steers | \$7.33 |
| 491-02919 | GL-2919 333SN19 | Haltec 19mm Sleeve Nut • Aluminum Steers • Steel/Steel Drives • Steel Outer/Aluminum Inner Drives | \$8.17 |
| 491-02928 | GL-2928 333SN28 | Haltec 28mm Sleeve Nut • HD Aluminum • Super Single • Wide Base • Aluminum Outer/Steel Inner Drives | \$8.50 |
| 491-02939 | GL-2939 333SN39 | Haltec 39mm Sleeve Nut • Dual Aluminum Drive Axle | \$9.00 |

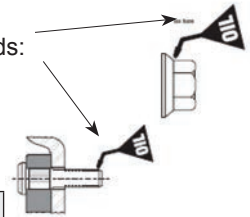

#606 Oil Can
\$11.95



1/8 - 16 Outer Cap Nut
891RZ/892LZ



995LZ/RZ
3/4 - 16 Super Single Cap Nut



269Z
Flange Wheel Nuts



881M/333B
Free Spinning Flange Nut
2203/2304



3/4 - 16 Outer Cap Nut
888RZ/889LZ



336RZ/337LZ - 13/16sq.
Inner Nut for Steel/Aluminum
Combination
Longer Version - 621RY/622LY



708RZ/709LZ
Grade 8.2 Inner
Nut-Aluminum Wheels



988RZ/LZ - 13/16sq.
Inner Cap Nut- Dual
Aluminum Wheels

| McGee No. | Mfg. No. | Similar To: | | Sale Price |
|--------------------------|----------|--------------------------|-------------------|------------|
| 891RZ (RH) | GL-2001 | Budd-37891/2 | Euclid-5552-R/L | \$.95 |
| 892LZ (LH) | GL-2002 | Nutum-W-13/14 | Batco-13-3012-R/L | \$.95 |
| 888RZ (RH) | GL-2101 | Budd-37888/9 | Euclid-5652-R/L | \$1.53 |
| 889LZ (LH) | GL-2102 | Nutum-W-15/16 | Batco-13-3013-R/L | \$1.53 |
| 995LZ (LH) | GL-2103 | Alcoa-5554 | Euclid-5554-R/L | \$5.08 |
| 995RZ (RH) | GL-2104 | Budd-70613/4 | | \$5.08 |
| 269Z | GL-2202 | GMC-3771410 | | \$2.13 |
| 881M | GL-2302 | (1 1/2 Hex) M.W. 88881 | | \$4.13 |
| 333B | GL-2301 | (1 1/4 Hex) Budd 106333 | | \$2.03 |
| Metric Outer Nuts | | | | |
| GL2009 | GL-2009 | Hino-9004-21112 | Isuzu-1-4233-023 | \$5.20 |
| GL2010 | GL-2010 | (Inner Thread = M30-1.5) | | \$5.20 |

| McGee No. | Mfg. No. | Similar To: | | Sale Price |
|------------------|----------|---------------------------------|-------------------|------------|
| 336RZ (RH) | GL-1003 | Budd-35336/7 | Euclid-5735 R/L | \$3.26 |
| 337LZ (LH) | GL-1004 | Nutum-W107/108 | Batco-13-3007-R/L | \$3.26 |
| 621RY (RH) | GL-1005 | Budd-22621/2 | Euclid-5568 R/L | \$3.68 |
| 622LY (LH) | GL-1006 | Nutum-W105/106 | Batco-13-3006-R/L | \$3.68 |
| 988RZ (RH) | GL-1011 | Alcoa-5988-R/L | Nutum-W-486/7 | \$3.55 |
| 988LZ (LH) | GL-1012 | Euclid - 5988-R/L | Batco 13-3026-R/L | \$3.55 |
| Grade 8.2 | | | | |
| 708RZ (RH) | GL-1001 | Euclid-7895R/L | Budd-10708/9 | \$1.53 |
| 709LZ (LH) | GL-1002 | BWP-M128/9 | Batco-13-3032R/L | \$1.53 |
| Metric | | | | |
| GL1009 (RH) | GL-1009 | Hino-9004-23101 | Isuzu-1-42335-005 | \$7.33 |
| GL1010 (LH) | GL-1010 | (M20 Inner & M30 Outer Threads) | | \$7.33 |

Air/Hydraulic Truck Service Jack

Designed for tire and wheel service on trucks, tractors and OTR vehicles. Includes return springs.

565E 22-Ton \$549.95

565E has one piece handle and includes extension set!

72200D Norco 22-Ton \$629.95



3591



Free dolly with 565E
Valid until 12-31-14

20 Ton Capacity Air/Hydraulic Bottle Jack

- Operates manually or with air eliminating hand pumping.
- Automatic bypass system.
- Extension screw provides extra lifting range
- Heavy duty base.
- Can be operated horizontally.
- Factory pretested

5520B \$220.00



NOW! 5520SD Heavy Duty Model - welded construction for longer life - \$275.00

Bottle Jacks

- Extension screw on some models
- Rust protection covering
- Uniweld construction
- 50% overload factor
- Fewer moving parts

ZN12 12-Ton \$84.00

ZNB22 22-Ton \$130.00



Truck Wheel Dolly

- Tire/wheel is rotated left or right on tiltable roller pads for perfect stud alignment
- Perfect for 8-10 hole Budd type wheels
- Removes truck wheels and tires fast and easy
- Increases productivity
- Reduces manpower needs
- Saves time and money—maintenance free
- Heavy duty tubular construction lifts 280 lbs.
- 3" caster wheels roll the truck wheels for effortless removal or replacement



| Ascot No. | McGee No. | Description | Price |
|-----------|-----------|-------------|----------------|
| 407-70130 | AFF3591 | Truck | \$99.95 |

"Combi" Tire Bead Breaker

- Works on a single, two and three-piece truck, agricultural and earthmover tire/rim
- Breaks beads in seconds using 10,000 lbs. of force
- No screws, bolts or attachments
- "Combi" bead breaker will not work on five-piece earth mover giant wheel/rim

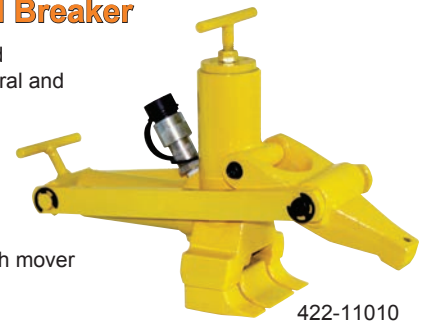

422-11010



422-16200

The 16200 upgrade kit can be added to Combi Bead Breakers in order to convert the tool so that it can work on new 3 piece wheels.

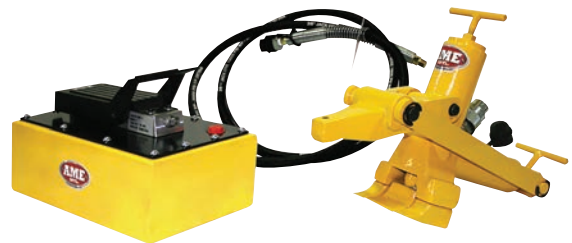

| Ascot No. | McGee No. | Description | Price |
|-----------|-----------|--|-----------------|
| 422-11010 | 11010 | Bead Breaker | \$575.00 |
| 422-12020 | 12020 | Bead Breaker Kit. INCLUDES: 11010 Bead Breaker, 15920 Pump and 16040 Hose Assembly | \$950.00 |
| 422-16200 | 16200 | Conversion Kit for Combi Bead Breaker | \$311.00 |

Modified "Combi" Tire Bead Breaker

- Modified 11010, the most popular tool for breaking beads on all agriculture wheels
- Most affordable bead breaker for new 3 piece wheel assemblies
- Modified jaw and feet allow for larger grab on larger wheel assembly
- All parts (except for modified feet and jaw) can be interchanged with 11010



| Ascot No. | McGee No. | Description | Price |
|-----------|-----------|------------------------------------|-----------------|
| 422-11020 | 11020 | Modified "Combi" Tire Bead Breaker | \$743.00 |

3 Piece Wheel Assembly

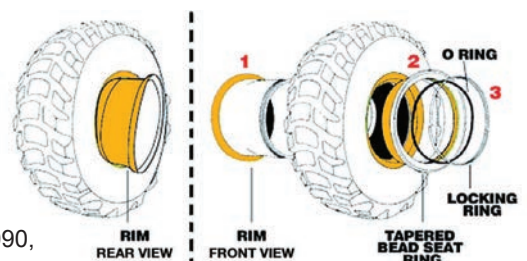

Use 11010, 11090, 11075, 11020

SOCKETS & SOCKET SETS

1/2" DR 13 Piece SAE Deep Set

* Contains the following sizes: 7/16", 1/2", 9/16" 5/8", 11/16", 3/4", 13/16", 7/8", 15/16", 1", 1-1/16", 1-1/8", 1-1/4"

| Ascot No. | McGee No. | Price |
|-----------|-----------|---------|
| 163-01151 | 1151D | \$69.95 |



1/2" DR 5 Piece Deep Thin Wall Flip Socket Set McGee #1205D

Includes the following 1/2" drive deep thin wall flip sockets:

- 3/4" x 13/16"
- 19mm x 21mm
- 7/8" x 15/16"
- 17mm x 19mm
- 3" extension
- Packaged in a durable plastic blow molded case
- 17mm x 19mm flip socket for European applications
- Equivalent to Grey 1504FW but with an extra socket

| Ascot No. | McGee No. | Price |
|-----------|-----------|---------|
| 167-12050 | 1205D | \$34.95 |



1/2" DR 9 Piece SAE & Metric Extra Thin Wall

- Durable outer sleeve and insert protects high-polished wheels and lug nuts from damage
- CR-MO alloy steel for long life
- Fully guaranteed
- Heavy duty molded storage tray
- Includes 6 SAE Sockets: 3/4" (light green), 13/16" (purple), 7/8" (green), 15/16" (brown), 1" (silver), 1-1/16" (black)
- Includes 3 Metric Sockets: 17mm (blue), 19mm (yellow), 21mm (red)

| Ascot No. | McGee No. | Price |
|-----------|-----------|---------|
| 163-02849 | 16302849 | \$69.95 |

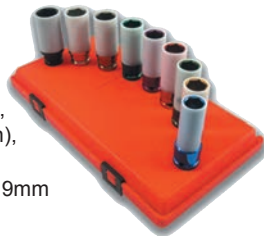

1" DR 10 Piece Truck Set

- Contains the following sizes: 13/16" square, 1-1/16", 1-1/8", 1-1/4" thin wall deep, 1-1/2" controlled standard socket, 17mm & 21mm square with inside lip, 33mm, 35mm & 41mm deep

| Ascot No. | McGee No. | Price |
|-----------|-----------|----------|
| 165-03110 | 3110 | \$179.95 |



3/4" DR 8 Piece SAE Deep Set

* Contains the following sizes: 1", 1-1/16", 1-1/8", 1-1/4", 1-5/16", 1-3/8", 1-7/16", 1-1/2"

| Ascot No. | McGee No. | Price |
|-----------|-----------|---------|
| 164-02181 | 2181D | \$99.95 |



Popular Truck Sockets

1" DR Square Impact Sockets



| Ascot No. | McGee No. | Description | Price |
|-----------|-----------|-----------------------|---------|
| 165-03026 | 3026S | 1" Dr. x 13/16 square | \$18.95 |
| 165-03030 | 3030S | 1" Dr. x 15/16 square | \$19.95 |

1" DR Combination Impact Sockets

| Ascot No. | McGee No. | Description | Price |
|-----------|-----------|-----------------------------------|---------|
| 165-03323 | 3323C | 1" Dr. 1-1/2" hex x 13/16" square | \$29.95 |
| 165-03321 | 3321MC | 1" Dr. 41mm x 21mm square | \$39.95 |

1" DR 1-1/2" Budd Wheel Impact Sockets

| Ascot No. | McGee No. | Description | Price |
|-----------|-----------|-----------------------------------|---------|
| 165-30481 | 3048D | 1" Dr. x 1-1/2" Deep w/inside lip | \$29.95 |
| 165-30482 | 3048DR | 1" Dr. x 1-1/2" Deep - standard | \$29.95 |

1" DR Metric Impact Sockets

| Ascot No. | McGee No. | Description | Price |
|-----------|-----------|----------------------|---------|
| 165-03033 | 3033MD | 1" Drive x 33mm Deep | \$32.72 |
| 165-03035 | 3035MD | 1" Drive x 35mm Deep | \$32.67 |
| 165-03041 | 3041MD | 1" Drive x 41mm Deep | \$35.72 |

1/2" Dr. Flip Socket Sale!

STD. "Flip" Socket & Metric "Flip" Socket

- Double-end reversible impact socket.
- Fits passenger and light truck wheel nuts.

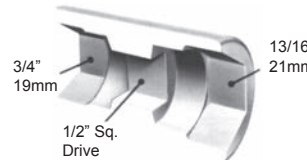

| Part No. | Description | Price |
|----------|-----------------------|---------|
| 1291D | 19mm-21mm | \$9.95 |
| 2192DT | Extra thin mm | \$9.95 |
| 1246D | 3/4"-13/16" deep | \$6.95 |
| 1246DT | Extra thin 1246D | \$6.95 |
| 2349D | 7/8"-15/16" thin deep | \$14.95 |

3-Piece Twist Socket Lug Nut Removal System

- Removal of damaged 3/4" and 19mm, 13/16" and 21mm lug nuts
- Two dual-sided twist sockets have a fluted design which gives the sockets a tight grip to remove the most difficult locking and damaged lug nuts from the socket
- Works with 1/2" impact gun or breaker bar for service calls
- Includes an extrator punch



| Ascot No. | Mfg. No. | Description |
|-----------|----------|---|
| 492-04300 | 4300 | 3-Piece Twist Socket Lug Nut Removal system |
| 492-04200 | 4200 | Dual Sided Twist Socket Lug Nut Remover |

Broken Inner Nut Remover

Remove broken inner bud nuts in MINUTES with our NEW tool

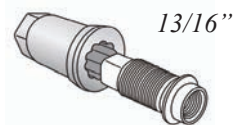

33105
\$54.95

Ken-Tool Impact Bead Breaker



- Loosens the most stubborn beads with floating bead breaking foot and ram bar
- Forces wedge foot between head and rim flange
- Delivers blow directly to the tip
- Designed for shop or road use

| Ascot No. | McGee No. | Description | Length | Length Ext | Weight Lb. | Price |
|-----------|-----------|-------------|--------|------------|------------|----------|
| 427-35924 | T24B | Economy | 46" | 72" | 13.5 Lbs. | \$136.69 |
| 427-35926 | T26B | Heavy Duty | 50" | 80" | 23 Lbs. | \$179.95 |

Duck-Billed Bead Breaking Wedges – Fiberglass Handled



| Ascot No. | McGee No. | Handle No. | Length | Weight | Price |
|-----------|-----------|------------|--------|----------|---------|
| 424-35429 | TG11E | TG11EH | 32" | 9.1 Lbs. | \$89.95 |

Heavy Duty Truck Torque Wrench - 168-12017

- Robust construction gives accurate results to +/-4% even in arduous work conditions
- Supplied with a calibration certificate to satisfy requirements of ISO 9000
- Break back action gives an unmistakable signal
- Break angle improves accuracy by reducing the possibility of overtorquing
- Dual scaled, Nm and ft./lbs.



Also available

1" Female x 13" Socket Extension! 169-03013 03013 - **\$39.95**
168-12017 - **\$549.95**

Tubeless Tire Iron Sets

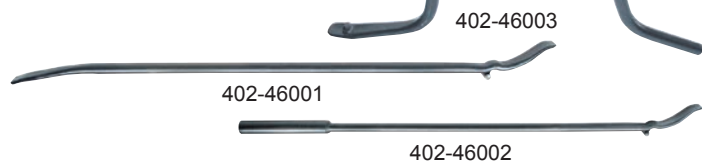

- Sets provide all irons necessary for a variety of tire changing applications
- Use C bar with the B extension bar for easier use on large, wide-base truck tires
- Use on standard and large truck tires, including industrial, farm, buses and tractors

| Ascot No. | McGee No. | Description | Length | Stock | Weight | Price |
|-----------------|-----------|--------------------------------|--------|-------|----------|---------|
| STANDARD | | | | | | |
| 402-46001 | T46A | Med. Duty Mount/Demount Iron | 36" | 3/4" | 4.5 Lbs. | \$49.45 |
| 402-46002 | T46B | Mount/Demount Iron | 36" | 3/4" | 4.5 Lbs. | \$55.40 |
| 402-46003 | T46C | Offset Bar For Deep Well Tires | 22" | 3/4" | 4.5 Lbs. | \$38.36 |

Golden Tool Tubeless Truck Tire Mount/Demount Tool

- Demounts/mounts 17.5" to 24.5" tires
- Use on all tubeless truck tires including super single/duplex tires, radial and bias
- Eliminates the need to lift tire and rim to remove the bottom bead, preventing possible strain or even serious injury



| Ascot No. | McGee No. | Description | Price |
|-----------|-----------|---------------|----------|
| 448-00100 | TNT100 | Complete Tool | \$569.95 |

Fiberglass Replacement Handles for Duck-Billed Bead Breaking Wedges

Handles are constructed with a solid core which has thousands of fiberglass strands and a unique resin making them super strong all-weather, chemical and insect-resistant.

Ergonomic non-slip grips for slippery conditions.

Replacement Adapters available.



Made in the USA

Made in the USA.



429-35227



429-35229

| McGee No. | Description | Price |
|-----------|---|---------|
| TG11DH | 19" Fiberglass Hammer Handle | \$33.95 |
| TG11EH | 33" Fiberglass Hammer Handle | \$37.95 |
| TG11DH1 | Replacement Nu-Lock Adapter for 19" Fiberglass Handle | \$10.03 |
| TG11EH1 | Replacement Nu-Lock Adapter for 33" Fiberglass Handle | \$10.72 |

BLUE COBRA Truck Tire Demount Tool



35440KT

\$299.95

INTRODUCING AN AFFORDABLE ALTERNATIVE!
Tougher build • Better price

Fast and easy, the Blue Cobra truck tire demounting tool is strong but economical the new "golden" standard for tire changing!

- Quickly demount nearly any 20", 22.5" and 24.5" tube-type and tubeless truck tire, up to a 13" wide wheel
- Solid steel Cobra head is press-fit into the steel handle — no fasteners to loosen or fall out
- Allows demounting of the tire without lifting the entire wheel and tire off the ground — helps to reduce back injuries.



Tubeless Truck Clamp-in Valves DIII - with U.S.A. made grommet!

Straight clamp-in valves used on both demountable and non-demountable rims. For .625" diameter valve hole.

Recommend installation torque 45 in - lbs

Available in BENT FORM - TR57213 - 13° - **\$1.61 ea.**



| McGee # | Effective Length | 100 Ea. | Cost Each |
|---------|------------------|---------|-----------|
| TR500 | 2" | \$1.00 | \$1.30 |
| TR501 | 1 1/2" | \$1.00 | \$1.30 |
| TR570 | 3 1/8" | \$1.08 | \$1.40 |
| TR571 | 3 3/8" | \$1.12 | \$1.46 |
| TR572 | 3 3/4" | \$1.17 | \$1.52 |
| TR573 | 4 3/8" | \$1.23 | \$1.60 |
| TR574 | 5" | \$1.26 | \$1.64 |

Import TR572IV - \$.99 ea!

Tire Valves - 540 Series

O-ring seal valves for Alcoa truck wheel (9.7MM Valve Hole)

Many production Alcoa aluminum wheels are manufactured with a 9.77MM valve hole that requires an O-Ring tire valve. Haltec valves have a high temperature resistant O-Ring and a heavy duty metal valve cap.

Recommend installation torque 100 in - lbs.

0330 O-ring available for TV540 Series
NOW! 100 ea TV545D - **\$1.59 ea**



| Valve TR No. | A Height | Bend Angle | B Length | Price ea. |
|--------------|----------|------------|----------|-----------|
| TV543 | 2.40 | - | - | \$2.61 |
| TV543D | .98 | 60° | 1.38 | \$2.64 |
| TV543E | .98 | 75° | 1.38 | \$2.64 |
| TV544 | 2.90 | - | - | \$2.97 |
| TV544D | .98 | 60° | 1.94 | \$2.97 |
| TV545 | 3.50 | - | - | \$3.24 |
| TV545D | .98 | 60° | 2.6 | \$1.99 |
| TV546 | 4.25 | - | - | \$3.17 |
| TV546D | .98 | 60° | 3.35 | \$3.38 |
| TV546E | .98 | 75° | 3.35 | \$3.42 |
| TV546G | .98 | 36° | 3.35 | \$3.31 |

Metric Clamp-In Valves - 550 Series

Popular on all new Alcoa wheels!

Compatible with aluminum wheel designs with 9.77mm valve hole.

- Viton grommets offer a greater temperature range, a better seal, and a longer service life — Maximum temperature 250°
- Easier installation with screwdriver slot.
- Recommend installation torque 45 in - lbs.

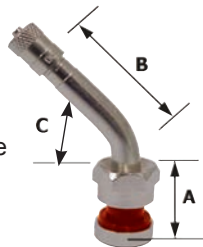

| McGee # | A | B | C | Price ea. |
|---------|------|------|-----|-----------|
| TV553 | 2.31 | - | - | \$4.28 |
| TV553C* | 0.93 | 1.38 | 45° | \$4.28 |
| TV553E* | .98 | 1.38 | 75° | \$4.28 |
| TV554D* | .98 | 1.94 | 60° | \$4.28 |
| TV555D* | .98 | 2.6 | 60° | \$4.28 |
| TV555E | .98 | 2.6 | 75° | \$4.28 |

*In Stock

Metric Rim Hole Valve - MS Series

(9.7mm Valve Hole)

- Some imported trucks will have steel wheels that incorporate the 9.7mm valve hole (.390")



Recommend installation torque 100 in - lbs

| McGee No | Ascot No | ETRTO | Bend | A | B | Price (ea.) |
|----------|-----------|---------|------|---------|---------|-------------|
| 70MS27 | 462-07025 | V3-20-5 | 27° | 1-3/16" | 1-9/16" | \$2.99 |
| 80MS27 | 462-08027 | V3-20-7 | 27° | 1-3/16" | 2" | \$2.99 |
| 90MS27 | 462-09027 | V3-20-4 | 27° | 1-3/16" | 2-3/8" | \$2.99 |
| 115MS27 | 462-11527 | V3-20-6 | 27° | 1-3/16" | 3-3/8" | \$3.99 |
| 41MS00 | 462-04100 | V3-20-1 | STR | 1-3/16" | — | \$2.99 |

Truck Grommets



| McGee # | Rim # | Fits | Used On |
|---------|-------|------------------|---|
| 5953 | RG-15 | .625 Valve Hole | TV-500 Series, TV-570 Series |
| RG15S | RG-15 | .625 Valve Hole | TV-500 Series, TV-570 Series red grommet 288° |
| G160 | RG-22 | .812 Valve Hole | H-41, T-81, T-30, DS-385, DS210 |
| 5093 | RG-46 | .625 Valve Hole | TV-509, 510, 511 |
| G-174 | RG-48 | .625 Valve Hole | TV-513, 515 |
| G170S | | .625 Valve Hole | Heat-Resistant Grommet for TV-570 Series (400°) green |
| 59765 | RG-54 | .453 Valve Hole | TV-416, 416L, 6008 |
| 525 | RG-39 | .625 Valve Hole | TV-416, 416L |
| G550 | RG-70 | .9975 Valve Hole | Fits TV-550 Series |
| 0330 | RG-30 | | TR-540 Series Valves |

Valve Stem Ratchet Wrenches



469-00018

| Ascot No. | McGee No. | Description | Price |
|-----------|-----------|-------------------------|---------|
| 469-00018 | VSW18 | For TR570 series valves | \$14.95 |
| 469-00020 | VSW20 | For TR540 series valves | \$16.95 |

Double Seal Cap

- A time, money and labor saving alternative to common valve caps
- Reduce pressure check time by 65%
- Designed for high pressure truck tire service
- Inflate, deflate or gauge directly thru the DS-1 saving time during inflation and pressure checks
- Automatic inflation systems lock right onto the DS-1
- Seals like a high pressure cap, yet offers the convenience of an inflate thru extension
- Performs like a check valve, the seal becomes tighter in the event of a core failure
- Heat resistant grommets provide additional protection for extended high temperature running
- Features tough all metal housing, precision fit brass components and durable self-sealing O-Ring



| Ascot # | McGee # | Description | Price |
|-----------|---------|-----------------|-------|
| 468-04191 | DS1 | Double Seal Cap | \$66 |

TIRE GAUGES



Now USA made Dill!

7212USA 20-120 PSI high pressure gauge
\$3.95

Automotive Tire Gauges



- Pencil, chrome tire gauges with nylon indicator bars

Imprinted Gauges Available with Your Name. Call for details!

| Ascot No. | McGee # | Range | Type | Price |
|-----------|---------|------------|---|---------------|
| 476-10105 | GA105 | 10-50 PSI | Passenger Gauge | \$2.99 |
| 476-10115 | GA115 | 20-120 PSI | High Pressure Gauge | \$2.99 |
| 476-10100 | GA100 | 1-20 PSI | Low Pressure Gauge | \$3.14 |
| 476-10110 | GA110 | 10-50 PSI | Passenger Gauge 75-340 kPa Calibrated in PSI & kPa | \$2.74 |
| 476-10125 | GA125 | 5-45 PSI | Air/Liquid Gauge - tractor | \$3.12 |
| 476-10145 | GA145 | 10-75 PSI | Mid-Range Gauge 70-500 kPa Calibrated in PSI & kPa | \$2.60 |

Counter Display

Retail Gauge Opportunity

Promote accurate tire inflation

211DIS — Counter Display with ten 10-50 lb. gauges

476-00211 **\$25.95**

941DIS — Counter Display with ten 10-120 lb. gauges

476-00941 **\$25.95**



7277USA Counter Display with ten USA made gauges - 10-75PSI **\$32.95**

Pocket Truck Gauges



| Ascot No. | McGee # | Description | Price |
|-----------|---------|--|---------------|
| 476-10150 | GA150 | Straight-On/Angled Gauge. 20-120 psi. Chrome Plated. | \$7.99 |
| 476-10160 | GA160 | Straight-On/Angled Gauge. 20-120 PSI. Black Baked Epoxy Protective Finish. | \$7.79 |
| 476-10130 | GA130 | Dual Foot Angled Pencil Gauge. 20-120 psi. | \$4.39 |



Now USA made
 7263USA **\$9.95**
 Straight-On/Angled Gauge
 20-120 PSI. Black Baked Epoxy Protective Finish.

USA made Dill gauges laser etched markings



SG1 - Externally Adjustable Plastic Bar Truck Gauge
 10-130 psi - **\$23.80**

SG2 - Externally Adjustable Metal Bar - Etched
 Truck Gauge 10-150 psi - **\$25.46**

Adjusting screw in end of indicator bar

Truck Service Gauges



- Wide variety of service gauges to accommodate the numerous tire and wheel configurations encountered by tire service personnel
- Available in chrome plated or protective black epoxy finish as indicated
- Calibrated from 10-150 psi in 2 pound increments
- Nylon or metal indicator bars

| Ascot No. | McGee No. | Gauge Type | Price |
|-----------|-----------|---|----------------|
| 476-10135 | GA135 | Angle Chuck With Nylon Bar | \$8.55 |
| 476-11135 | GA135S | Same As Above, Angle Chuck With Metal Bar | \$9.63 |
| 476-10155 | GA155 | Straight-On With 30° Reverse Chuck | \$12.79 |
| 476-10165 | GA165 | Same As Above, Straight-On With 30° Reverse Chuck, Black Epoxy Finish | \$9.41 |
| 476-11155 | GA155S | Same As Above, Straight-On With 30° Reverse Chuck, Metal Bar | \$12.92 |
| 476-10185 | GA185 | Dual Foot Service Gauge With Nylon Bar, 180° Chuck, Chrome Plated | \$11.77 |
| 476-01046 | 7285E | Externally Adjustable Metal Bar Truck Gauge – 10-150 psi | \$10.95 |

Master Air Pressure Station

\$149.00-MAPS

This station is used as a test pressure source for calibration of air gauges. Unit can be wall mounted on 1/2" npt pipe. TIA recommends regular calibration of truck tire gauges to maintain accuracy and assure proper tire inflation. The tire gauges listed below can be adjusted to maintain accuracy.



Ball Foot Chucks

| Ascot No. | McGee No. | Description | Price |
|-----------|-----------|---|--------|
| 478-00335 | 5499 | Ball Foot Chuck. 1/4" Female Thread (Normally Closed) | \$2.79 |
| 478-00315 | 5567 | Ball Foot Chuck With Lock-on Clip. 1/4" Female Thread (Normally Closed) | \$7.49 |

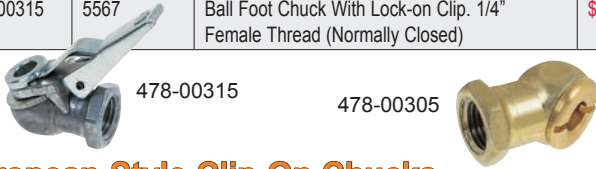

European-Style Clip-On Chucks

| Ascot No. | McGee No. | Description | Price |
|-----------|-----------|---|--------|
| 478-02985 | CH360 | European-Style Clip-On Chuck. 1/4" Female Fitting. Silver Clip. (Normally Closed). | \$6.59 |
| 478-02995 | CH360OP | European-Style Clip-On Chuck. 1/4" Female Fitting. Black Clip. (Normally Open). | \$6.59 |
| 478-01200 | N1200 | European-Style Clip-On Chuck. Serrated Shank for 1/4" I.D. Hose. Silver. (Normally Closed). | \$4.59 |



Made in the USA

| McGee No. | Description | Price |
|-----------|--|--------|
| 6293DUSA | European-Style Clip-On Chuck, 1/4" Female Fitting. Silver Clip. (Normally Closed). (CH360) | \$7.29 |
| 6293EUSA | European-Style Clip-On Chuck. 1/4" Female Fitting. Black Clip. (Normally Open). (CH36001) | \$7.29 |

Couplers & Nipples

- Steel plated couplers with hardened steel balls and stainless steel springs
- Plugs heat-treated to reduce wear on critical mating surfaces
- Interchange with Tru-Flate 10 and 100 type series as well as units produced by other manufacturers
- Maximum working pressure 300 psi.

Automotive Standard Series "G"

| Part No. | Description | Price |
|----------|---------------------------|---------|
| 3505 | 1/4" Coupler Male | \$5.46 |
| 3506 | 1/4" Nipple Male - USA | \$1.90 |
| 3507 | 1/4" Nipple Female - USA | \$1.97 |
| 3515 | 3/8" Coupler Male | \$11.83 |
| 3517 | 3/8" Nipple Male | \$2.73 |
| 3518 | 3/8" Nipple Female | \$3.50 |
| 3512 | 1/2" Coupler Female - USA | \$10.80 |
| 3513 | 1/2" Nipple Male - USA | \$6.17 |
| 3514 | 1/2" Nipple Female - USA | \$6.80 |



ASCOT

Tire Tread Depth Gauges



| Ascot No. | McGee No. | Description | Price |
|-----------|-----------|---|--------|
| 454-00599 | 595TM | Tire Tread Depth Gauge. Used to measure tire tread depth in 1/32" increments | \$2.39 |
| | 5124 | Red-Yellow-Green Tread Depth Gauge: Allows your customer to visually display when tires should be replaced due to tread wear. | \$2.49 |

Large Bore Air Chucks



| Ascot No. | McGee No. | Description | Price |
|-----------|-----------|---|---------|
| 478-00377 | 377 | Long Lock-On Air Chuck. | \$20.57 |
| 478-00322 | 322 | Large Bore Dual Foot Air Chuck. 45° Chuck For Easy Access To Valve. 1/4" NPT Female Thread. | \$33.83 |
| 478-04660 | H4660A | L/B Clip-on Air Chuck 1/4" NPT | \$23.55 |



Single Bend Swivel Valves

| Ascot No. | McGee No. | TR No. | Bend Angle | Horizontal Length "L" | Vertical Height "H" | Price |
|-----------|-----------|--------|------------|-----------------------|---------------------|--------|
| 465-00650 | WH300J650 | J-650 | 80° | 3 1/8 | 1 5/64 | \$9.95 |
| 465-00653 | WH300J653 | J-653 | 80° | 2 1/2 | 1 5/64 | \$9.95 |

Miscellaneous Valves



| | | |
|-----------|---|--------|
| 465-00670 | T670 Loader Tire Valve complete with core, hex cap and "O" ring seal. Thread size is 1-1/16-12. Height is 1-25/32". | \$9.46 |
| 465-00702 | H41 Tubeless Spud (TR-SP-2), used with all Large Bore Swivel Valves. Fits 13/16" rim hole. Height is 11/16". | \$2.46 |
| 465-06703 | H45 Spud and Valve Complete (TRJ-670-3) Consists of H-41 & H-42. Height is 1 5/8". | \$9.96 |



Large Bore Caps and Cores

| Ascot No. | McGee No. | Description | Price |
|-----------|-----------|---|--------|
| 465-00145 | A145 | Large Bore Core (Short) Fits 305-32 threads | \$1.19 |
| 465-00148 | A148 | Screwdriver Valve Cap. Fits .482-26 threads | \$1.29 |
| 465-00149 | A149 | Hex Valve Cap fits .482-26 threads | \$1.26 |
| 468-00100 | 655TM | Adapts large bore down to std. (AD1) | \$2.01 |
| 468-08007 | 656 | Same as 655TM but cap style | \$2.24 |

VALVE STEMS

Ford "F" Series Truck Valve

- Ford "F" series with dual wheels
- Alcoa aluminum 16" wheels
- Front and rear wheels
- Chrome finish
- Dual seal cap not included

\$2.49 ea.



| Ascot No. | McGee No. | Description |
|-----------|-----------|-----------------------|
| 462-01600 | VS902WP | Ford "F" Series Valve |

Ford "Cut-Away" and Cargo Van Series Valve

- Ford "cut-away" and cargo van series with single rear wheels
- Accuride steel 16" x 7" wheels
- Front and rear wheels
- Dual seal cap not included

\$1.86 ea.



| Ascot No. | McGee No. | Description |
|-----------|-----------|------------------------------------|
| 462-01575 | TR575 | Ford "Cut-Away" & Cargo Van Series |

Ford "F" Series Truck Valve

- Ford "F" series with dual wheels
- Accuride steel 16" x 6" wheels
- Front and rear wheels
- Nickel finish
- Includes dual seal cap

\$1.50 ea.



| Ascot No. | McGee No. | Description |
|-----------|-----------|-----------------------|
| 462-02416 | VS962C | Ford "F" Series Valve |

Enkel Valves

- A high performance "No Show" type chrome plated valve that installs from the outside
- A rubber washer and nut are on the inside
- Fits .453" diameter hole



| Ascot No. | McGee No. | Description | Price |
|-----------|-----------|-------------------------|---------------|
| 462-06010 | TV6010 | 3/4" Length, Standard | \$1.49 |
| 462-06020 | TV6020 | Bent at 45° Angle | \$1.99 |
| 462-06030 | TV6030 | 1-1/4" Length, Standard | \$2.31 |
| 462-06040 | TV6040 | 1-3/4" Length, Standard | \$2.46 |

Quality valves assure trouble free service!

Chrome Sleeve TV600HPC

461-01600 (TR600HP-C)

- For use in high pressure applications
- Rated to 100 PSI
- Includes core, cap and chrome sleeve
- Fits .453" rim



Chrome-Sleeve Snap-In Type Tubeless Tire Valves

\$1.19 ea



- Standard snap-in type tubeless tire valves are fitted with an attractively designed hexagon valve cap and chrome sleeve to cove the valve stem area
- Available in two lengths to fit .453" valve holes.

| Ascot No. | Mfg. No. | Eff. Length | Price |
|-----------|----------|-------------|-----------------|
| 461-41211 | 412SC | 7/8" | \$.49 ea |
| 461-41311 | 413SC | 1-1/4" | \$.59 ea |
| 461-41811 | 418SC | 2" | \$.69 ea |

High Pressure Snap-In Valves — DIII OE

- Tubeless snap-in type valves for high pressure applications
- Maximum cold inflation pressure is 100 psi
- For .453" or .625" rim holes
- Do not use on tire rims that exceed .205" in thickness



| Ascot No. | TR No. | Eff. Length | Valve Hole Dia. | Sale Price |
|-----------|---------|-------------|-----------------|---------------|
| 461-00600 | TV600HP | 1.27" | .453" | \$.69 |
| 461-00602 | TV602HP | 2" | .453" | \$.89 |
| 461-00801 | TV801HP | 1.25" | .625" | \$.89 |
| 461-00802 | TV802HP | 2" | .625" | \$1.01 |

TV600HPiv import - 100 each - **\$.28 ea**

TR416 Clamp-In Tubeless Tire Valves

- Nickel plated metal valves can be installed in all passenger cars, light trucks and industrial rims with .453" or .625" valve holes
- Rubber grommet forms a seal when valve is clamped to rim by tightening hex nut
- Maximum inflation pressure is 130 psi
- Includes 2 rubber grommets

| Ascot No. | McGee No. | Eff. Length |
|-----------|-----------|-------------|
| 462-00416 | 3640 | 1-1/4" |
| 462-36415 | 3641 | 2" |

3640 - 1/4"

\$.99 ea.



Chrome Hi-Performance Valve

Perfect for Custom Wheels

Chrome plated valve and sealing cap. Especially suited to custom wheels. Includes grommets for .453" and .625" passenger car wheels.

5991B

462-00800
3/4"

\$.79 ea.



Valve for 16 X 6KS with Oval Hole

- Oval rim slot valve for 16 x 6KS and 16 x 6-1/2LS rim contours
- Allows a positive seal in this special valve hole
- Check the valve hole for metal burrs prior to installation

\$1.29 ea.

| Ascot No. | McGee No. | Description |
|-----------|-----------|---------------------|
| 462-05010 | H5010V | Oval Rim Slot Valve |



Radial Commander Valve For 15° Disc Wheels

- 23° bend clamp-down valve for .625" valve hole
- Bend allows clearance of brake drum for tire service

\$2.94 ea.

| Ascot No. | Part No. | Description |
|-----------|----------|------------------------|
| 462-01147 | N1147 | Radial Commander Valve |



| Ascot No. | McGee No. | Description | Finish | Price |
|-----------|-----------|--|---------|---------------|
| 46805005 | CAP S | Combination Cap/Sleeve for TR413 | Chrome | \$.18 |
| 46800660 | 660V | Standard Black Plastic Valve Cap (100) | Plastic | \$1.99 |

| Ascot No. | Mfg. No. | Operating Pressure Range | Operating Pressure | Price |
|-----------|----------|--------------------------|--------------------|----------------|
| 468-05405 | 5405V | 0-200 PSI-Peaks of 300 | 90 PSIG | \$10.99 |

5405V cannot be used in aluminum TPMS items

| Ascot No. | Mfg. No. | Description | TR No. | Operating Pressure | Finish | Price |
|-----------|----------|-------------------------------|--------|--------------------|---------------|----------------|
| 468-07572 | 7572V | Dome-Shaped Top & Guide (100) | VC3 | 0-200 PSI | Nickel Plated | \$12.99 |

VALVE TOOLS

Valve and Core Tools



469-00005



469-00607

469-00992



469-00033



469-15407



| Ascot No. | McGee No. | Description | Price |
|-----------|-----------|---|----------------|
| 469-00005 | TL685 | For both standard and large bore valves. | \$1.38 |
| 469-00607 | TL620 | Has plastic screwdriver handle for better grip and leverage. | \$1.99 |
| 469-00992 | 610 | Tubeless Tire and Tire Valve Inserting and Removing Tool. For all sizes of snap-in passenger car tire valves | \$6.55 |
| 469-00033 | 50103 | No-Mar Valve Stem Remover & Installer. Installs and removes tubeless valves without marring or scratching chrome and alloy wheels | \$14.95 |
| 469-15407 | 5407 | Tubeless Tire Valve Inserting and Removing Tool with Core Tool Built Into End | \$11.61 |

Valve Nut Torque Wrenches

These wrenches give the user two sensory indentifiers indicating to the user that the application of torque has been achieved for tightening the fastener. Both a tactile impulse and a visual indicator alert the user that complete and proper torque has been applied.



\$63.00 ea.

Remove Truck Valves Quickly!

\$179.95



| McGee # | Description |
|----------|---|
| 16801942 | Valve Nut Torque Wrench - 9/16" - Visual indicating torque wrench for TR570 series tire valves. Preset at 42 in./lbs. |
| 16810100 | Valve Nut Torque Wrench - 5/8" - Visual indicating torque wrench for TR540 & TR550 series tire valves. Preset at 100 in./lbs. |

| Ascot | McGee | Description |
|-----------|----------|---|
| 469-22011 | 46922011 | Valve Blaster Truck Valve Stem Removal Tool Removes valves quickly. Slide hammer with an internal spring absorbs the shock of impact. Easy to use. Designed to shear the bottom flange off the valve with one or two blows. OAL - 63" |
| 469-22012 | 46922012 | Replaceable End for Valve Blaster Truck Stem Removal Tool - \$78.00 |

Standard Bore Valve Tools



| Ascot No. | McGee No. | Description | Price |
|-----------|-----------|---|----------------|
| 469-52000 | 52000 | Valvecapper is 11.5" long-designed to reach the inner valve on dual wheel. One end is for the removal/installation of valve caps and the other end is removal/installation of the core | \$11.70 |
| 469-05262 | 6108 | Tube Deflating Aspirator. Screwing aspirator onto valve mouth and applying air chuck to threaded inlet creates vacuum that siphons air from tube | \$2.08 |
| 469-00011 | TL645 | Cable Valve Fishing Tool. Valve core wrench and deflating pin with flexible cable for fishing valve through rim hole. 24" | \$1.92 |
| 469-00002 | 4205 | Black Heat Treated Heavy Duty Tire Valve Repair Tool. 4-in-1 standard valve tool repairs cap threads, repairs core threads. Easy out feature for removing damaged cones & removing standard caps. | \$4.95 |
| 477-00001 | 1406M | Safety Inflator Gauge. 12" hose with dual foot chuck. 10 to 120 PSI. Available 6 ft., 9 ft., & 12 ft. hose | \$39.95 |
| | TL132 | Sure-Lock Valve Core Tools allow the valve core to stay attached to the tool after it is removed from the valve. A great tool to keep the valve core from getting dropped or lost. TL132 - 2" Cars, TL133 - 5" Trucks TL134 - 4" Large bore | \$10.07 |



TL132



469-00011



469-00002



M Series

PREMA - REMA TIRE REPAIR

PREMA Radial Repairs - Passenger and Light Truck

PREMA Center-Over-Injury Repairs are designed for use in all radial tires. The PREMA Radial Repair is intended for use in HOT or COLD applications. PREMA Radial Repairs are designed for use in the crown, sidewall and shoulder of radial tires. Install with PREMA Ultra Fast Dry Vulcanizing Cement. Refer to the PREMA Repair Chart for proper selection of the repair unit. Always fill the injury channel with the appropriate Prema repair material.



| Ascot No. | McGee No. | Description | L (in.) | W (in.) | # Plies | Qty/Box | Price |
|-----------|-----------|--------------|---------|---------|---------|---------|---------|
| 575-05109 | PR109 | Radial 109 | 3 | 1 3/4 | 1 | 20 | \$17.59 |
| 575-05100 | PR110 | Radial 110 | 3 1/4 | 2 1/4 | 1 | 20 | \$18.80 |
| 575-05105 | PR110B | Radial 110 | 3 1/4 | 2 1/4 | 1 | 80 | \$72.67 |
| 575-05120 | PR112 | Radial 112 | 4 3/4 | 3 | 1 | 10 | \$17.34 |
| 575-05125 | PR112B | Radial 112 | 4 3/4 | 3 | 1 | 40 | \$67.34 |
| 575-05130 | PR113 | Radial 112HD | 5 | 3 1/4 | 1 | 10 | \$24.75 |
| 575-05140 | PR114 | Radial 114 | 5 1/4 | 3 1/2 | 1 | 10 | \$24.75 |
| 575-05200 | PR120 | Radial 120 | 5 | 3 1/4 | 2 | 10 | \$37.95 |
| 575-05350 | PR135 | Radial 135 | 7 1/2 | 5 1/2 | 4 | 10 | \$92.75 |
| 575-05400 | PR140 | Radial 140 | 7 3/4 | 4 1/4 | 3 | 10 | \$73.55 |

PREMA Universal Repairs

PREMA Universal Repairs are designed for NAILHOLE REPAIRING of tubeless tires in the CROWN area only. Universal Repairs are available in round or square versions. Install with PREMA Ultra Fast Dry Vulcanizing Cement. Always fill the injury channel with the appropriate Prema repair material.



| Ascot No. | McGee No. | Description | L (in.) | W (in.) | Qty/Box | Price |
|-----------|-----------|--------------------|---------|---------|---------|---------|
| 550-00502 | PUR2 | Universal Round 2 | 2 1/4 | -- | 50 | \$28.69 |
| 550-00522 | PUS2 | Universal Square 2 | 1 3/4 | 1 3/4 | 100 | \$31.95 |
| 550-00533 | PUS3 | Universal Square 3 | 2 1/2 | 2 1/2 | 100 | \$49.75 |
| 550-00534 | PUS4 | Universal Square 4 | 3 | 3 | 50 | \$37.21 |

Ultra Fast Dry Vulcanizing Cement

PREMA Ultra Fast Dry Vulcanizing Cement is formulated to provide outstanding performance when used in conjunction with PREMA Repair Materials. Contains no ozone depleting chemicals.



| Ascot No. | McGee No. | Description | Size | Price |
|-----------|-----------|---|------------|---------|
| 501-00508 | PFC8 | Ultra Fast Dry Vulcanizing Cement (Flammable) | 8 fl. oz. | \$8.95 |
| 501-00532 | PFC32 | Ultra Fast Dry Vulcanizing Cement (Flammable) | 32 fl. oz. | \$29.95 |

Pre-Buff Cleaner

PREMA Pre-Buff Cleaner is formulated to remove contaminants and silicone from the innerliner of the tire prior to buffing. Contains no ozone depleting chemicals.



| Ascot No. | McGee No. | Description | Size | Price |
|-----------|-----------|------------------------------|----------|---------|
| 505-00532 | PPC32 | Pre-Buff Cleaner (Flammable) | 32 fl oz | \$11.95 |
| 505-00516 | PPC16 | Pre-Buff Cleaner (Aerosol) | 16 fl oz | \$7.95 |

RAD 100 Series Radial Repair Units

RL110 Bulk 30 Per Bag - \$42.95

REMA RAD 100 Series center-over-injury repair units has replaced older styles of non-flex to non-flex patches throughout the entire world . . . virtually revolutionizing the process of radial repair patch reinforcement.



| Ascot No. | McGee No. | Patch Size Inches | (mm) | Qty/Box | Price |
|-----------|-----------|-------------------|----------|---------|---------|
| 575-00110 | RAD110 | 2 x 2-3/4 | 55 x 75 | 20 | \$39.95 |
| 575-00115 | RAD115 | 3-1/2 x 3 | 70 x 115 | 10 | \$49.95 |
| 575-00120 | RAD120 | 4-7/8 x 3 | 85 x 130 | 10 | \$49.95 |

Rema Tip Top Universal Patch

The Hole Solution™ - The only patch you'll ever need for making a nail hole repair. For radial and bias-ply passenger or truck tires.



UP6 — Special — \$48.95!

| Ascot No. | REMA No. | Injury Size | Qty. | Price |
|-----------|----------|----------------|------|----------|
| 550-26707 | UP3 | Small Nailhole | 100 | \$55.95 |
| 550-26714 | UP45 | 3/16" Nailhole | 300 | \$239.95 |
| 550-26721 | UP6 | 1/4" Nailhole | 50 | \$59.95 |
| 550-26745 | UP8 | 5/16" Nailhole | 50 | \$79.95 |



Rema tire tube patches are renowned for their easy application and extraordinary effectiveness. A unique rubber compound allows the patch to stretch evenly and equally in all directions upon inflation, assuring a reliable bond and minimal bulging in any service condition.

| Ascot No. | McGee No. | Units Size | Per Box | Price |
|-----------|-----------|--------------|---------|---------|
| 541-00410 | 1 | 1-1/2" Round | 30 | \$7.99 |
| 541-00420 | 2 | 1-3/4" Round | 30 | \$16.95 |
| 541-00430 | 3 | 2" Round | 30 | \$20.95 |

Patch should be 1/2-inch larger in both width and length than the injury.

Rema Minicombi Repair Units & Accessories

Part of Rema's renowned Blue Bonding System™, Minicombi features a metal pilot guide for easy installation and seating. Specially designed for tread area punctures on both radial and bias-ply tires, Minicombi should be used with Special Cement BL.



| Ascot No. | McGee No. | REMA# | Description(Units/Box) | Price |
|-----------|-----------|-------|----------------------------|----------|
| 581-67050 | 670RM | A3 | 1/8" Minicombi A3 (50/Box) | \$89.95 |
| 581-67340 | 673RM | A6 | 1/4" Minicombi A6 (40/Box) | \$110.95 |
| 581-68008 | B8MC | B8-MC | 5/16" Minicombi B8 (20) | \$82.88 |

Extruders



High quality Bosch or SD drive, adjustable heat controls, 110 Volt

| | | | |
|---------|-----------|-------------|-----------------|
| 260685 | 550W/110V | Bosch drive | Call for Price! |
| 260685S | 750W/110V | SD drive | Call for Price! |

Nailhole Extruder

| | | | |
|---------|-----------|----------|-----------------|
| 260670P | 400W/110V | SD drive | Call for Price! |
|---------|-----------|----------|-----------------|

Tire Repair Knife

- High carbon steel, round point skiver, round burnt finish handle (riveted)



| Ascot No. | McGee No. | Blade Length | Price |
|-----------|-----------|--------------|--------|
| 531-75190 | X2RF | 4" (102mm) | \$8.99 |

- High carbon steel, taper point, glaze finish, round burnt finish handle (riveted)



| Ascot No. | McGee No. | Blade Length | Price |
|-----------|-----------|--------------|--------|
| 531-75190 | X2T | 4" (102mm) | \$7.98 |



- Clean out small injuries

| Rema No. | McGee No. | Description | Price |
|-----------|-----------|-------------|--------|
| 537-95893 | 261RT | Reamer | \$3.95 |



SLP-9400 Overhose Kit

| Ascot # | McGee # | Description | Price |
|-----------|---------|---|---------|
| 173-09165 | 2500 | Quick Change Chuck | \$22.18 |
| 173-09201 | 2510 | 1 1/16" x 3/8"-24 Chuck Adap. w/Washer & Nut | \$4.40 |
| 173-09202 | 2511JD | 2 3/4" x 3/8"-24 Chuck Adap. w/Nut & Wheel Spacer | \$6.20 |
| 173-09211 | 2512JD | 1 7/8" x 3/8"-24 Threaded Adap. w/Washer & Nut - Quick Change | \$2.78 |
| 173-09212 | SLP9212 | 2 1/4" long x 3/8" - 24 Threaded Adap. w/ Washer & Nut Quick Change | \$4.40 |
| 173-09213 | 2522 | 1 5/16" Adap. w/Set Screw for 1/8" Shank | \$2.18 |
| 173-09215 | 2523JD | 1 5/16" Adapter w/Set Screw for 1/4" Shank | \$2.18 |
| 173-09216 | SLP9216 | 1 5/16" Adapter w/Set Screw for 5/16" Shank | \$3.00 |
| 173-09400 | SLP9400 | Overhose Kit | \$17.98 |

Wire Brushes

Ideal for buzzout repair of radials

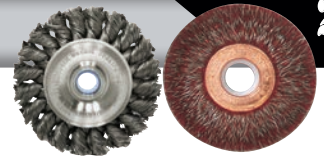

535-08014

535-15463

Copper Center® Wire Wheel Brushes-Wire Fill

| Ascot No. | McGee No. | Dia. | Wire Size | Arbor RPM | Hole | Price |
|-----------|-----------|------|-----------|-----------|-----------|---------|
| 535-15463 | 15463 | 2" | .0118" | 20,000 | 1/2"-3/8" | \$8.08 |
| 535-15533 | 15533 | 3" | .006" | 20,000 | 1/2" | \$12.06 |
| 535-15543 | 15543 | 3" | .008" | 20,000 | 1/2" | \$9.93 |
| 535-15563 | 15563 | 3" | .0118" | 20,000 | 1/2"-3/8" | \$9.53 |

Knotted Brushes

| | | | | | | |
|-----------|-------|----|--------|--------|----------|-------|
| 535-08014 | 08014 | 3" | .014" | 20,000 | 1/2-3/8" | 25.28 |
| 535-08034 | 08034 | 4" | .0118" | 20,000 | 1/2-3/8" | 29.25 |

Rubberhog® Tire Repair Tools

The controlled wide-open structure provides generous cutting clearance between the "SSG" teeth allowing them to easily penetrate and cut off small, cool chips of rubber without loading.

Flared Contour/Precision Contour Wheels

- Redesigned to most effectively use their "SSG" tooth armors
- Working faces of the wheels are at an angle to the shaft, which makes it easy to clear the handpiece for working inside and outside of casings
- Wide and nearly flat working face radius produces the ideal texture over a wider contact area for a more even textured surface



538-10700

| Ascot No. | McGee No. | Description | Price |
|-----------|-----------|---|---------|
| 538-10700 | RH107 | 2-1/2" Contour Wheel 3/8" Bore, SSG 170 | \$26.27 |
| 538-10900 | RH109 | 2-1/2" Contour Wheel 3/8" Bore, SSG 230 | \$25.76 |

Heavy Duty Air Tire Buffer

- Quick change chuck for easy bit change
- Piped-away exhaust directs air away from work area and user (included)
- Comparable to CP873

15810873 - \$69.95

Piped-away exhaust hose included



1/4" Shaft Spheres

- Larger Spheres are excellent for high-tread skiving
- Smaller Spheres chamfer around injuries on liner; don't take a chance on entrapped air!



538-60100

| Ascot No. | McGee No. | Description | Price |
|-----------|-----------|----------------------------------|---------|
| 538-60100 | RH601 | 5/8" Sphere, 1/4" Shaft, SSG 330 | \$14.47 |
| 538-60300 | RH603 | 7/8" Sphere, 1/4" Shaft, SSG 330 | \$18.36 |

New! Curved Diagonal Cutting Plier - Lap Joint

- Curved diagonal for maximum pulling leverage
- Perfectly mated cutter, heat treated to hold its edge
- Polished high carbon drop forged steel
- CHANNELLOCK BLUE comfort grips



319-00447 \$27.92

| Ascot No. | McGee No. | Length | Weight | Jaw Length | Joint Thickness | Joint Width | Cutter Length |
|-----------|-----------|--------------|-------------------|--------------|-----------------|--------------|---------------|
| 319-00447 | CHA447 | 7-3/4" 195mm | 10.67 oz. 302 Gr. | 1-1/32" 26mm | 1/2" 12.5mm | 1-1/16" 27mm | 1-1/32" 26mm |

TIRE REPAIR ACCESSORIES

Xlight Tire Service LED Work Light

- Designed for hands-free lighting during tire service and other work applications
- 12" adjustable spring-tube for optimum light positioning within tight spaces
- Compact high-power LED light provides up to 300 LUX for intense focus and optimum visibility.
- Clamp-on handle quickly and easily grips over the bead of a tire
- Compatible with all passenger, light truck & commercial truck tires
- Compatible with all tire spreaders
- Multiple high-power magnets on the handle and light head attach easily to most metal surfaces
- Lithium-Ion rechargeable battery



Xlight Tire Service LED Work Light
\$42.95

The clamp on handle quickly and easily grips over the bead of a tire.

| Ascot No. | McGee No. | Description |
|-----------|-----------|------------------------------------|
| 312-14921 | 31214921 | Xlight Tire Service LED Work Light |

Quart Cement Dispenser with Plastic Handle Brush

| Ascot No. | Description | Price |
|-----------|--|---------------|
| 532-14381 | Quart Cement Dispenser with Plastic Handle Brush | \$9.95 |



532-14881
Quart Cement Dispenser with Plastic handle Brush

Spray Bottle



| Ascot No. | McGee No. | Description | Price |
|-----------|-----------|-----------------------------|---------------|
| 632-00922 | 565B | 16 oz. Poly Trigger Sprayer | \$4.90 |

Carbide Cutting Tools



| Part No. | Description | Prices |
|----------|---|-----------------|
| BU18T | 1/8" Taper Burr (PCC1) | \$7.69 |
| BU14T | 1/4" Taper Burr (PCC2) | \$30.88 |
| BU38T | 3/8" Taper Burr (PCC4) | \$27.13 |
| BU12B | 1/2" Ball Burr | \$25.00 |
| BU732N | 7/32" Long Pointed Burr (Use with 1/4" Plug) | \$30.00 |
| BU516N | 5/16" Long Pointed Burr (Use with 3/8" Plug) (PCC3) | \$49.60 |
| BU716N | 7/16" Long Pointed Burr (Use with 1/2" Plug) | \$111.33 |

Markal® Paintstik® Marker



Permanent, waterproof and fadeproof. Marks on wet tires, withstands retreading temperatures. Nontoxic, contains no lead. Sold 12 per box. Other colors available.

| Ascot No. | McGee No. | Color | Price |
|-----------|-----------|--------|---------------|
| 459-80257 | MKWhite | White | \$9.00 |
| 459-80258 | MKYellow | Yellow | \$9.00 |

Tire Marking Crayons

- Bright Color On Any Tire
- Will not melt, soften or rub off in the pocket. A quality crayon that marks on tires, tubes and rubber. Sold 12 per box.

| Ascot No. | McGee No. | Color | Price |
|-----------|-----------|--------|---------------|
| 459-51420 | 51420 | White | \$4.99 |
| 459-51421 | 51421 | Yellow | \$4.99 |

Professional Stitchers

- Corrugated ball bearing stitcher with hardened steel wheel and varnished wooden handle



| Ascot No. | Part # | Description | Price |
|-----------|--------|------------------------------|---------------|
| 536-00001 | 30 | 1-1/2" Diameter x 1/16" Face | \$6.99 |

- Used to inspect injuries in tires and to remove small stones and debris



| Ascot No. | McGee No. | Description | Price |
|-----------|-----------|------------------|---------------|
| 537-00001 | 1013P | Black Handle Awl | \$4.82 |

Buffing Wheels



| Ascot No. | McGee No. | Description | Price |
|-----------|-----------|---|----------------|
| 539-00033 | 33 | 3/8" - 24 Arbor for mounting buffing wheels | \$4.15 |
| 539-10001 | BC1 | Fine grit coarse, round-nose buffer wheel, Tungsten Carbide 2 1/2" diameter — use on tires or tubes | \$3.50 |
| 538-13000 | 1030G | 2" fine tooth buffing cone-Ideal for passenger inner liners | \$14.95 |
| 538-01034 | 1034T | 2" med. tooth buffing cone-Ideal for passenger inner liners | \$19.95 |
| 539-00788 | | (2) No. BC-1 buffing wheels mounted back-to-back on No. 33 Arbor (order item separately) | |
| 538-14000 | RH140 | Faster, cleaner buffing; avoid burning | \$22.95 |



- This tool is a must for professional tire repairs
- Eliminates power buffing on many tire repairs
- Scraper removes material that might contaminate buffing wheels, ensuring a better repair every time

| Ascot No. | McGee No. | Blade Length | Price |
|-----------|-----------|----------------------------------|---------------|
| 537-00004 | 933 | Black Handle Inner Liner Scraper | \$5.71 |

HYDRAULIC JACKS

**“THE BEST WARRANTY
IN THE INDUSTRY”**

McGee Company offers one year over the counter warranty on the 3-1/2 Ton - 350GT Service Jack. Ask your McGee representative for details!

3-1/2 Ton Professional Heavy Duty Floor Jack Model 350GT

AFF's Model 350GT is "forge-tough" for daily service use. It is ideal for use in tire shops, mechanical repair facilities and roadside assistance service vehicles where ruggedness, strength and durability are required.

- Lifts from 4" to 19-1/2"
- Pinned steel saddle (1-1/8" stud) with rubber pad for added vehicle protection
- Rear mounted 2-3/4" swivel casters for ease of maneuverability
- High strength steel yoke
- One piece 50-1/4" padded handle parks upright
- Ship weight 117 lbs.

\$299.95



Jack Oil HF100
\$6.75 Qt.

3-1/2 Ton Professional Heavy Duty Double-Pumper Floor Jack Model 350SS

This unit offers all the features of our Model 350GT with additional speed and efficiency thanks to AFF's double-pumper advantage for quicker lifting.

- Lifts from 4" to 19-1/2"
- Pinned steel saddle (1-1/8" stud) with rubber pad for added vehicle protection
- Rear mounted 2-3/4" swivel casters for ease of maneuverability
- One piece 50-1/4" padded handle parks upright
- Ship weight 119 lbs.



\$335.00

Replacement power unit for the 350 Series and 200T Jacks

Before you replace your jack, consider installing a new power unit

**350GT Jack Power Unit is
350GTKHU**

**350SS Jack Power Unit is
350SSKHU**



**\$109.95 ea. for all
350 and 200 models**

2-Ton Low-Rider Floor Jack Model 200T

Our Model 200T floor jack is built with our traditional AFF quality, perfect for today's lower-profile "tuner" vehicles. It quickly lifts from a low 2-3/4" to 20" with AFF's double-pumper advantage.

- Universal joint technology and precision release valve for a more controlled release
- Pinned steel saddle (1" stud) with rubber pad for added vehicle protection
- Tough UV powder coated frame for greater protection and durability
- One piece 50" handle for ease of positioning, pumping and storage
- Ship weight 99 lbs.

\$229.95



7-Ton Forklift Jack - Model 3917

The scissor jack point on the AFF 3917 is low enough to efficiently access and lift a variety of popular forklift models.

- Scissors lift from 2-1/2" to 16-1/2"
- 14" reach in raised position
- Safety valve provides critical overload protection
- Rugged wheels make load alignment easier
- Chassis 26" long x 9" wide
- Ship weight 150 lbs.



\$565.95
AFF3917

30" x 16" Polypropylene Shop Cart Model #: 961

AFF Product

\$199.50

- Dimensions: 30" x 16" x 3" Deep
- 5" Diameter x 1" Non marking casters (2 swivel, 2 fixed)
- Overall dimension: 39-3/4" L x 17" W x 33-1/4" H
- Convenient organizer tray integrated into cart handle
- Super strong polypropylene cart will not rust or peel
- 500 lb. overall capacity



| Model | Capacity (tons) | Ram Lift | Low Height | High Height | Reach | Width | Ship Wgt. (lbs) |
|-------|-----------------|----------|------------|-------------|-------|--------|-----------------|
| 3917 | 7 | N/A | 2-1/2" | 16-1/2" | 14" | 9-7/8" | 150 |

72500E Transmission Jack

- 1/2-ton capacity
- Fully adjustable
- Built-in safety overload
- Foot operated pump
- Wide base for stability

72500
\$799.00



Model 81033 and Model 81034—3/4 Ton Capacity

Designed to support vehicle components, not the vehicle. Ideal for exhaust system installation & shock absorber replacement.

- Light weight, slender design makes handling easy in close quarters.
- Quick adjust spin handle with trust bearing eliminates wear and provides ease of turning under load.
- Foot pedal (model 81034 only) generates 1" additional stroke and 400 pounds of force at the saddle.
- Pedal may be locked in vertical position for storage or shipment.
- 1-1/4" diameter threaded screw has 26-1/2" of travel.

81033A - \$99.95 • 81034A (with foot pedal) - \$109.95



81034A

COMPRESSORS

Quincy QT® Compressors — “Rated #1”



**5-Year
Warranty
Program**

- Quincy's True Blue 5-Year Warranty
- Register unit within 10 days after purchase to activate warranty
- Purchase and use genuine Quincy filters and lubricant during the warranty period. (Proof of purchase required)
- Receive a 5-year limited warranty on the compressor.
- Receive a 2-year limited warranty on the package.
- Motors and engines are warranted by the original manufacturer.



**5HP - 80 gal. - 3ph
253D80VCB-3MAG — \$2,095⁰⁰**

Meticulously designed for maximum productivity. Completely rebuildable with stainless steel valves and heavy duty cast iron crank case and cylinders. Leading the industry with the most CFM per brake horse-power. Includes ASME receiver, enclosed belt guard, high efficiency motor, and loadless auto stop/start.



| Part No. | HP | Electric Spec. | ACFM at 175 PSI | Tank Size | Tank Style | Price |
|-----------------|-----|----------------|-----------------|-----------|------------|---------|
| 251CS80VCB1MAG | 5 | 230V, 1ph | 17.2 | 80 | vert. | \$2,395 |
| 271CS80VCB1MAG | 7.5 | 230V, 1ph | 22.6 | 80 | vert. | \$2,695 |
| 273D80VCB3MAG | 7.5 | 230V, 3ph | 22.6 | 80 | vert. | \$2,695 |
| P2103D12HCB3MAG | 10 | 230V, 3ph | 35 | 120 | horz. | \$3,695 |

High Quality, Inexpensive, Double Wall Tanks!

- High density blow molded plastic, seamless inner tank
- UL listed
- Easier and faster to fill



Unique double wall design

| McGee # | Tanks | Price |
|------------|------------------------------------|---------|
| 2335103401 | 110 Gallon Tank 29"W X 28"L x 44"H | \$799 |
| 2335101861 | 165 Gallon Tank 29"W X 28"L X 61"H | \$879 |
| 2335101862 | 275 Gallon Tank 43"W X 28"L X 61"H | \$1,079 |
| 2335102642 | 400 Gallon Tank 64"W X 30"L X 68"H | \$2,069 |

Oil King

- Large 25 gallon capacity with sight gauge
- Convenient tool trays and filter areas
- Large offset collection pan with screen
- Oversized tires to get over hose and rough floors

238866 — Now! \$389.00

238866



Gas-Driven, Two-Stage Industrial Air Compressors



- Highly efficient — Leading the industry with more CFM per brake hp
- Lasting performance — Heavy duty, cast iron construction ensures durability
- Enhanced details — State-of-the-art design and virtually maintenance free
- Complete confidence — Full, two year warranty available

Pressure lubricated 11 HP and 13 HP models are available

Call for Prices!

| Ascot No. | McGee Model No. | HP | Engine | Tank Size (Gal) | CFM @ 175 psig | Wt (Lbs.) |
|-----------|-----------------|----|--------|-----------------|----------------|-----------|
| — | G213H30HCB | 13 | Honda | 30 | 23.6 | 515 |
| 102-21230 | G214K30HCD | 14 | Kohler | 30 | 23.6 | 502 |
| 102-13730 | HGR73H | 13 | Honda | 30 | 23.2 | 409 |

Champion models - stock in Dallas — H Series

**LUBRICATION SPECIALISTS
CALL TODAY ~ 800-525-8888
30+ YEARS EXPERIENCE!**



Fireball Pumps



Air Diaphragm Pumps



GRACO



Enclosed and Open Reels



Lightweight, Electronic Meters



THE WORLD'S MOST TRUSTED LIFT...

World Leader in Lift Systems

Revolution RFP14
In Stock - F.O.B. Denver

\$3995^{00!}



Model Shown
RFP14
14,000 lbs. capacity

RFP14 Features:

- Hydraulic cylinder placed under runway and out of the way
- Multi-position locks allow runways to be level at any lock position
- Single joint latch release system
- Air latch and power unit controls located on front of column
- Can be converted to alignment add rolling jacks, air kit and ramps

10,000-18,000 lb. 2 Post

Narrow Bay and Low Ceiling Model Available!

Arm Adapters Packages

10,000 lb. capacity lift:
Three-Stage Flip-Up Adapters with built-in truck adapters on standard arms

12 to 18,000 lb. capacity lift:

Thread Up Stackable Inserts designed for heavier vehicles, (additional stack adapters available)

TA Adapters also available for 10,000 lb. capacity lift

RA - 3 stage arms give more reach – perfect for *low profile* vehicles



10,000 lbs. Capacity

Model SPOA10

Call for additional details on rotary lifts!

Lifts designed for high volume commercial applications

The new Y12 lift - general service or alignment • Call today for details 800-525-8888

Y12-Wide Wheelbase Range - Flat Top Surface

Flush Mounted or Recessed



Validated by ETL
Shown: YA12NX
12,000 lbs. capacity

True Up / Down Movement
20% More Work Area and Better Lift Access!

12,000 lb. Capacity

- 33% faster speed of rise
- Hydraulic cylinder, locking mechanism and position sensor are protected inside and under the runways

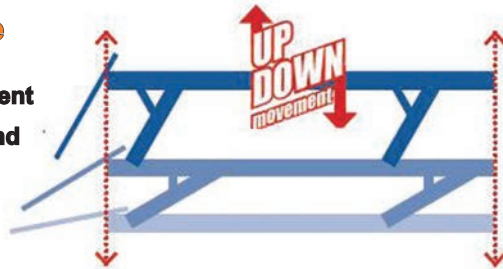

Unlike a parallelogram, the YA12 provides true up/down lifting. There is no forward or rearward movement reducing valuable bay space.

Equipment Specialists



Chuck Abourezk



Rich Caballero
Hablo Espanol!



SM301 - 30,000 LBS. LIFTING CAPACITY

Rolling Jack Available



Model Shown RJ7000Z



20" Wide Fixed Runways



Model Shown
AR014N001BL

Available in CLOSED FRONT

Since 1925, Rotary Lift has built quality in to everything we do. As the oldest U.S. lift manufacturer, our lifts are built and cycle tested for years of trouble-free service. Rotary lifts are backed by full warranty and are supported by McGee Company.

TIRE CHANGER ACCESSORIES

5500 Low Profile Bead Lever Tool

Now \$49.95

Patent Pending



Designed by technicians to assist with hard to change low profile tires.

The easy grip ergonomically designed handle allows the user needed leverage for the toughest of sidewalls while remaining a safe distance from the face of the wheel.



Plastic Handled Brass Sidewall Brush

- Densely packed brass bristles
- Great for cleaning white sidewall tires



| Ascot No. | McGee No. | Description | Price |
|-----------|-----------|---|--------|
| 395-13124 | 99593 | 8" Plastic Handled Brass Sidewall Brush | \$4.57 |

Wooden Handled Wire Brush with Metal Scraper



| Ascot No. | McGee No. | Description | Price |
|-----------|-----------|--|--------|
| 535-00150 | 25150 | 14" Wooden Handled Wire Brush with Metal Scraper | \$4.95 |

Coats® Rim Clamp® Wheel Protection Accessories

\$31.50/pkg

444-83604
183604 Quilted Clamp Sock
(Package of 10)



444-83606
183606 BL Shoe Sock
(Package of 2)

\$25.59/pkg



- Decrease the chance of damaging expensive alloy wheels by putting a "sock" over three Rim Clamp action points and eliminate metal to metal contact.
- Put your profits into the bank, not into replacing alloy wheels.
- The above socks fit all COATS Rim Clamp models.

Part # 108397 **Special**
444-08397 **\$1.76**
Mount End



Part # 108398 **Special**
444-08398 **\$1.76**
Demount End

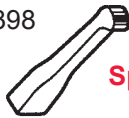

Head, Mount/Demount, Polymer

Hunter TC3250/3500
(1 ea.) Part
#RP60343B
444-01221



\$18.95 ea.

Hunter TC500 Series

(1 ea.) Part
#RP118314813



\$33.00 ea.



Tire Changer Lube Bottles And Swabs

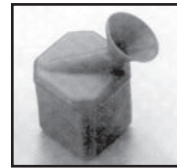

844-16572



844-16259



| Ascot No. | McGee No. | Description | Price |
|-----------|-----------|---|--------|
| 844-16572 | 106572 | Lube Bottle. Center-Post. Fits 4040, 4040SA and 4050 | \$9.95 |
| 844-16259 | 106259 | Lube Bottle. Rim Clamp®. Fits RC-15, RC-20, 5060, 5070, 50X and 70X Tire Changers | \$8.95 |
| 000491 | 437-00491 | Lube Swab - 11 inch | |
| TS3 | 437-00003 | Lube Swab - 18 inch | |

Rema Euro Paste

\$12.95

432-00750 #75 - Mounting Paste 7.7 lb.
432-01750 #75N - Low Profile Pail



Eases mounting of stiff, low-profile tires. Aids in faster bead sealing during inflation. Preferred when servicing tires on ABS-equipped or HP vehicles. Prevents vibration complaints as a result of tire moving on wheel after balancing.



\$10.59

437-43006 #73 - Brush, Angled Applicator

Allows for proper application of mounting paste.

Plastic Inserts for 182788 Metal Mount/Demount Head (Pkg of 2) Model 182961

444-82788
\$5.83



Plastic Inserts for 182788 Metal Mount/Demount Head (Pkg. of 12) Model 182963

444-82963
\$23.04

Mount - Demount Tools

Part # 000768 **Special**
444-00768 **\$64.27**



For All Center- Post Tire Changers

Part # 181354 **Special**
444-81354 **\$34.95**



For All Rim Clamp Tire Changers

Drop Center Tool

Part # 435685
444-35658 **Special**
\$39.95



A Must for "V" & "Z" Rated Tires

Plastic Duckhead Kit

Part # 183061
444-01220 **Special**
\$26.85



Fits 50X, 60X, & 70X machines

New Grip Max standard on X models ~ \$479.75



6"-22" External Clamping on 50X & 70X
9"-30" External Clamping on APX
Set of 4 Grip Max Plus Clamps p/n 85607787

8560716108 replacement black grip for new style Grip Max Plus
\$36.79 (8 each)

Challenge: Damage-free clamping of alloy wheels

- Plastic clamp covers are missing, or are not installed by technicians, resulting in metal-to-metal contact with wheel
- Current plastic clamp covers are difficult to use on stiff-sidewall applications.
- Chromed wheels can slip during service while clamped externally.

8500059408 replacement white grip for old style Grip Max
\$31.74 (8 each)



COATS TIRE CHANGERS

Model 70 Series Rim Clamp

At the heart of the X-Series Tire Changer is an upgraded Rim Clamp® chassis, refitted with upgrades to increase your productivity, convenience, and uptime. All of these valuable upgrades are now standard across the entire X-Series line. So, today you get much more for your money.

X-Series Upgrades, Standard on all Models:

1 ADVANCED CLAMP POSITIONING

- Allows for greater control when clamping wheels
- Position clamps exactly where needed at any point between fully in and fully out
- No need to wait for the clamps to have to cycle the full range



(70X pictured)

2 OIL INJECTION SYSTEM

- Direct injection more effectively distributes oil to the moving components ensuring better lubrication to reduce wear and lengthen life expectancy
- Designed to prevent oil from being wasted during tire inflation
- 55 fl. oz. container holds over a year's worth of oil for most shops, significantly reducing the need for regular replenishment

3 "ROBO-ARM® READY" TOWER

- Larger tower comes standard on all models for easier future Robo-Arm® upgrade on 50X models

4 PLASTIC CHASSIS STORAGE

- Durable plastic storage tray keeps your tools right where you need them
- Helps keep your work area neat and organized

5 ADVANCED HAND BEAD LOOSENER OPTION

- Available as an option at no additional cost — just order an "H" version
- Provides power in, power out, and hold capability to improve control and efficiency
- Operation located at the point-of-use, improving visibility in order to reduce the chance of rim damage

CALL FOR PRICE!

Specifications
Clamping 6" - 24"
Rim Width 3" - 14"
Tire Diameter 50"

"Perfect for low profile tires"

5040 Series Rim Clamp® Tire Changer

- Clamps wheels externally up to 21"
- Conveniently-placed foot pedals that give you precise control over every step of the changing process
- Provides protection for wheels at every step of the process.
- Optional bead loosener socks, clamp booties, and lift tool protection prevent metal-to-metal contact that causes scratching or marring.



\$3,595⁰⁰

Premium Set 70X Standard with 3 Series

The premium set gives you the tools to handle the widest breadth of applications.

You get all the features of the extended set plus an upgraded high-spoke mount/demount head and Duckhead® roller.

We also added our premium tower storage cabinet, perfect for keeping all your tools right on hand.



| Ascot No. | Mfg. No. | Description |
|-----------|----------|-----------------------|
| 443-50400 | 5040A | Air Drive System |
| 443-50401 | 5040E | Electric Drive System |

BRAKE LATHES



Brake lathe covers required to be OSHA compliant

Ammco 2800 cover for Ammco lathes

Model 20-2122-1 cover for Hunter lathes



In Stock

- The most popular on-car lathe among OEMs.
- Can complete cut of a rotor in an average of 8 minutes.
- Designed for shops servicing cars through medium trucks.

Call for details – 800-525-8888

LESS DUST IN THE AIR, CLEANER FLOORS, A QUIETER SHOP, ADDED SAFETY AND CONVENIENCE

A SAFE CLEAN WORK AREA

- Enclosing your lathe maximizes safety.
- Less dust in the air means easier breathing.
- Less shavings on the floor reduces slip risks.
- Easily monitor progress through the large viewing window.
- Put your lathe up front for walk in customers.
- Make your shop compliant with OSHA rules.

1450 Brake Washer

OSHA preferred low pressure method.

3 stage filtration

- Large particle strainer
- 20 micron sock
- 5 micron cartridge

Water based biodegradable solution

Reusable oil absorbing boom

Runs on standard shop air



BITS — AMMCO, HUNTER, KWIK-WAY, ACCUTURN

Silencers



6921



6922



6930AM



8500



7075

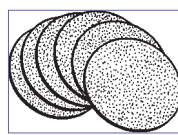

8756



9183



9800

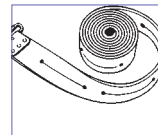

5280



5290



6920

Drum & Rotor Silencers

| Ascot # | Part # | AMMCO Description | Price |
|-----------|--------|--|----------|
| 416-05280 | 5280 | Silencer Band - Drum 1-3/4" | \$26.09 |
| 416-05290 | 5290 | Silencer Band - Drum 2-3/4" Truck Drums | \$36.19 |
| 416-06920 | 6920 | Silencer Band - Ventilated Rotor | \$18.54 |
| 416-06921 | 6921 | Silencer Band - Non-Vented Rotor 6.5" (Pkg 2) | \$6.26 |
| 416-06922 | 6922 | Silencer Band - Non-Vented Rotor 9.250" (Pkg 2) | \$6.26 |
| 416-06930 | 6930AM | Silencer Band - Rotor - Heavy Duty. Ventilated | \$42.93 |
| 416-07075 | 7075 | Rotor Friction Silencer for 2002, 4000, 4100, 7000 | \$219.16 |
| 417-08500 | 8500 | Drum Micrometer | \$348.67 |
| 416-08756 | 8756 | Abrasive pads for 8750 | \$12.96 |
| 416-09183 | 9183 | Replacement Pressure Pads - Non-Asbestos (Pkg 2) | \$10.64 |
| 416-09800 | 9800 | Silencer Assembly - Spring - Vented - Rotor | \$26.79 |

Now! 06610 round bits Faster turn!

Round Carbide Bits for all Tool, Ammco, Hunter BL500 series, Performance and Rels lathes.

Use with 06700 holder. **\$84.34**



10 pk

06610 - \$35.60



Why pay for propellant?

Sure-Shot Sprayer

Great way to dispense brake cleaner and other chemicals. To operate, load liquid and pressurize with air chuck. Easy!



| Ascot No. | Part No. | Description | Sale Price |
|-----------|----------|---|------------|
| 418-40410 | 940410 | Carbide Insert, Pos. Rake, for FMC1 Lathes, 10pk. | \$34.00 |
| 418-40415 | 940415 | Carbide Insert, Pos. Rake, for KWIK-WAY2 Lathes, 10pk. | \$50.44 |
| 418-40420 | 940420 | Carbide Insert, Neg. Rake, for HUNTER3 Lathes, 10pk. | \$25.99 |
| 418-40430 | 940430 | Carbide Insert, Neg. Rake, for PERFORMANCE4 Lathes, 10pk. | \$20.00 |
| 418-40435 | 940435 | Carbide Insert, Pos. Rake, for ACCUTURN5 Lathes, 10pk. | \$40.57 |
| 418-16263 | 2216263 | Carbide Insert for Hunter OCL 360 on the car lathe, 10pk. | \$59.25 |
| 418-06914 | 691410 | Carbide Insert, Negative Rake AMMCO lathes, 10pk., 1000, 2002, 3000, 4000, 4100, 7000, 7700 | \$19.97 |
| 418-69186 | 69186 | Carbide Insert, Positive Rake, AMMCO 3850 Lathe, 6pk. | \$30.30 |
| 418-06910 | 06910 | Carbide Insert for Pro Cut 610 On-The-Car Lathe, 10pk. | \$31.21 |

| Ascot # | McGee # | Description | Price |
|-----------|---------|--|---------|
| 632-02400 | 2000 | 1 Qt Rust Resistant Chrome Plated Brass Tank | \$84.53 |
| | KM10 | Repair Kit for 2000 | \$28.58 |

McGee Company stocks the largest selection of tire service supplies and automotive equipment throughout the western United States. With over thirty sales representatives averaging eight years of experience, we can help you solve your service needs. Orders ship from one of our four warehouses encompassing a total of 40,000 square feet. McGee Company offers same day shipping on most orders with a 96% fill rate on tire supply products.

What separates our tire supply and equipment programs from the competition?

- On-site equipment demonstration
- Equipment trade-in
- Customer training - TPMS - proper tire repair, equipment maintenance - TIA truck tire service certification
- Dallas, Salt Lake City, and Denver interactive equipment showrooms
- In-house leasing - Flexible payment plans
- Quality products - Knowledgeable staff
- Project coordination - Single point of contact to coordinate new service facility equipment installation.



New! ENGINEERED FOR SPEED AND ACCURACY...BUILT TO LAST - COATS® BALANCERS

Coats® 1100 Series Wheel Balancers feature four key balancing technologies that together work to provide a fast and accurate balance, the first time, every time...for years to come.

Coats 1100 Series

All Coats 1100 Series Balancers come fully equipped with the following:

DIRECT BALANCING MODE SELECTION

Choose weight locations quickly, with the touch of a button.

MULTIPLE BALANCING MODES

Dynamic with simultaneous static, four standard alloy options and truck mode.

AUTO START HOOD

Blazing fast balancing cycle begins when you lower the hood.

REDESIGNED USER INTERFACE

Optimized for speed and simplicity.

DUAL OPERATOR MODE

The 1100 Series saves the vehicle data for two operators, maximizing shop work flow.

MATCH BALANCE

Determines the optimal position of the tire on the rim to minimize corrective weight.

- Automatic distance and diameter data entry maximizes the speed and accuracy of data entry.
- Direct Tape-A-Weight® measurement takes the guess work out of adhesive weight balancing for more one-spin balances.
- Behind the Spoke weight placement hides adhesive weights out of sight for a clean look on alloy wheels.

STATIC-ON-SCREEN®

Static-on-Screen is an exclusive Coats feature that simultaneously displays both static and dynamic unbalance data. This provides a final quality check to identify any excess residual static unbalance, a leading cause of vibration complaints.



Basic adapters package included with 1150 models

IN STOCK -- CALL FOR BEST PRICE!

Truck Cone Kit

#113276 482-11559

\$270.16

#113277 482-12385



Allows balancing truck wheels with center holes from 4¹³/₁₆" to 6⁷/₈". Used on rims with an alignment pin on the back. Double-sided cone fits all Coats balancers with 1.125" shafts. 40mm. 113277 or 113276 - 28 mm

USED – DEMO – CLOSE-OUT – REBUILT



BFH1000

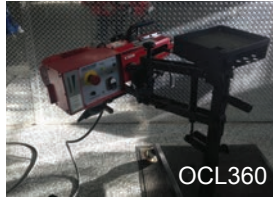

OCL360



OCL360 Adapters



8710



UE2195



NTF15



QRS5HP3

| PROD. # | QTY | AIR TOOLS | SPECIAL |
|---------------------------------|-----|---|------------|
| UE1638 | 1 | USED CP7775SP6 AIR WRENCH | \$200.00 |
| UE1886 | 1 | USED CP7775SP6 1" SPLINE | \$200.00 |
| UECP772 | 1 | FACT RECON CP772 AIR WRENCH | \$150.00 |
| UE2229 | 1 | RECON CP797SP6 SPLINE DR. 1" GUN (SLC) | \$150.00 |
| UE2230 | 1 | RECON CP797SP6 SPLINE DR. 1" GUN (SLC) | \$150.00 |
| UECP734 | 1 | FACT RECON CP734 1/2 AIR WRENCH | \$50.00 |
| USED EQUIPMENT | | | |
| UE2291 | 1 | ROTARY 14K 4POST OPEN FRONT SMO14EL2 | \$5,000.00 |
| UE2282 | 1 | HUNTER ON THE CAR LATHE W/ADAPTERS OCL360A | \$2,000.00 |
| UE1990 | 1 | FACTORY REPAIRED EL16 BRANDER(SLC) | \$100.00 |
| UE810SLC | 1 | GRACO EM5 OIL METER(SLC) | \$150.00 |
| UE811SLC | 1 | GRACO EM5 AFT METER(SLC) | \$150.00 |
| UE1903 | 1 | AMMCO 2508B LONG BENCH | \$300.00 |
| UE2195 | 1 | USED REMA REPAIR STATION(SLC) | \$2,500.00 |
| UE1555 | 1 | RECON BBH10 BEAD BREAKER(SLC) | \$349.00 |
| UE2106 | 1 | DEMO TNT200 (ALBQ) | \$300.00 |
| UE036 | 1 | USED EEC4 FORD COMPRESSION TESTER(DEN) | \$100.00 |
| UE1259 | 1 | USED BEAR ELECT SYS TESTER MODEL ARBST(DEN) | \$99.95 |
| UE1301 | 1 | DEMO ZN22 BOTTLE JACK (DEN) | \$69.95 |
| UE2062 | 1 | USED COATS 112897 BALANCE ADAPTERS | \$199.00 |
| UE2063 | 1 | USED COATS 112898 8 LUG STUD PLATE | \$99.00 |
| UE2075 | 5 | USED HUNTER 20-1328-1 ADAPTER KIT(DEN) | \$99.00 |
| UE2078 | 1 | NEW HUNTER 20-2172-1 PRESS ARM KIT(DEN) | \$549.00 |
| UE730 | 1 | USED 453322 22T JET JACK(DEN) | \$89.95 |
| UE849 | 1 | USED PR5 HANKISON DRYER(DEN) | \$199.00 |
| UE2195 | 1 | USED REMA 6551 TIRE REPAIR STATION (SLC) | \$2,500.00 |
| UE2293 | 1 | JBC BFH 1000 DIAGNOSTIC BALANCER | \$5,000.00 |
| DEMO OR NEW EQUIPMENT CLOSE OUT | | | |
| XR1800 | 1 | NEW COATS PREMIUM BALANCER 115V(DEN) | \$5,000.00 |
| WB601 | 1 | NEW CORGHI BALANCER (DEN) | \$1,695.00 |
| NTF15 | 2 | DEMO RTI NITROGEN UNITS(DAL, ALBQ) | \$1,500.00 |
| BFX2 | 1 | DEMO BRAKE FLUSH MACHINE (SLC) | \$1,500.00 |
| ATX2 | 1 | DEMO TRANSMISSION FLUID EXCHANGER (SLC) | \$1,500.00 |
| 50X EF2 | 1 | NEW COATS RIM CLAMP ELECTRIC | \$5,450.00 |
| 333610 | 1 | JET ARBOR PRESS 1 TON (SLC) | \$90.00 |
| 8710 | 1 | NEW ACCUTURN DRIVE FOR ON CAR LATHE (SLC) | \$950.00 |
| SP1DT | 1 | AUTOMETER DIGITAL LOAD TESTER (SLC) | \$250.00 |
| 07C6521 | 1 | OTC DIAGNOSTIC SMOKE EVAPORATOR (SLC) | \$500.00 |
| A10IRA3 | 1 | NEW ROTARY 10K 2 POST ASYM INBAY (SLC) | \$3,300.00 |
| 2019101 | 1 | HUNTER PRET BALANCER ADAPTER KIT (SLC) | \$1,100.00 |
| 4021 | 1 | OTC AIR/HYD PUMP W/REMOTE (SLC) | \$245.00 |
| 2021531 | 1 | HUNTER LOW TAPER BALANCER ADAPTER KIT (ALB) | \$1,200.00 |
| 1 DB-24MB | 1 | NEW HUNTER ALIGN. STANDS W/TP (DEN) | \$1,500.00 |
| 78908 | 1 | NORCO 1250LB. ENGINE STAND (DEN) | \$350.00 |
| 5055 | 1 | ANTIFREEZE RECYCLES (DEN) | \$1,000.00 |
| 54200 | 1 | GOODSELL ANTIFREEZE RECYCLER (DEN) | \$1,000.00 |
| 17200 | 1 | NEW ROBINAIR COOLTECH R12 REC/RECY | \$2,200.00 |
| QRS5HP3 | 1 | NEW CP SCREW COMP. 5HP 3PH. | \$4,100.00 |



XR1800



50X EF2



A10IRA3



UE2230



UE1886



UE1555

McGeeCompany.com Online Resources

HUNTER
Engineering Company



AMMCO® COATS
Hennessy Industries



1-800-525-9888 **SEARCH**

ABOUT US | DIVISIONS | MANUFACTURERS | **RESOURCES** | REQUEST INFO | CONTACT US | TPMS | SPECIALS

[Current Sales Flyer & Assoc Catalog](#)
[Manufacturer Videos](#)
[MSDS Information](#)
[Product Breakdown](#)
[Dill TPMS](#)
[Schrader EZ Sensor](#)
[Chain Sizes-Passenger](#)

VALVE HARDWARE
McGee Company specializes in valve hardware for all tire inflation applications. Puzzled by a tire inflation issue? Contact us to figure out your needs. We stock Schrader and Dill as well as import valves, hardware, gauges and tools for passenger, truck and OTR. Need help sizing your valve based on your mode? Check out our Schrader and Dill guides to get the exact model.

ONLINE ORDERING LOGIN

• Username

• Password

LOGIN

[forgot your password?](#)
[request account](#)

AUTOMOTIVE SERVICE EQUIPMENT & SUPPLIES
McGee Company stocks the largest selection of Automotive Service Equipment & Supplies and tire service supplies (wheel weights) throughout the Western United States.

COMPRESSED AIR PRODUCTS
Reciprocating compressors, rotary screw compressors, vacuum systems and air treatment components.

LUBRICATION EQUIPMENT SYSTEMS & PARTS
Lubrication service equipment, supplies, and used oil handling products for auto dealerships, quick lube, service shops, commercial service centers and industrial applications.

VIEW MORE **VIEW MORE** **VIEW MORE**

- Product breakdowns
- MSDS
- TPMS charts
 - o Schrader
 - o Dill
 - o Relearn procedures

- Tutorial videos
- Online shopping
 - o Build shopping lists
 - o Review previous orders
 - o See detailed photos



McGEE COMPANY

Welcome, Ian | English (\$100) | Sign Out

3 Items \$14.67 **Checkout**

Continue shopping

Showing 1 - 8 of 8 Results Page: 1

| Item Number | Description | Quantity Avail | Unit Price | Savings Per | Quantity | Unit Measure |
|-------------|---------------------------------------|----------------|-------------|-------------|----------------------|--------------|
| 8051 | BUFFING WHEEL 2-1/2" 5/8" AN | 100 EA | \$3.00 EA | \$0.00 | <input type="text"/> | EA |
| 802002 | THIS PLASTIC TRAY (100) ACC KITS | 5 EA | \$12.16 EA | \$0.00 | <input type="text"/> | EA |
| 80003E | GREEN ALUMI NITRO CAP 100 ALUMI STEMS | 10 BOX | \$20.00 BOX | \$0.00 | <input type="text"/> | BOX |
| 8333 | DOCKET SET 40 SP IPC | 1 EA | \$109.03 EA | \$0.00 | <input type="text"/> | EA |
| 802000 | EZ SENSOR 433 MHz THIS SHAP IS STYLE | 12 EA | \$17.00 EA | \$0.00 | <input type="text"/> | EA |

Showing 1 - 8 of 8 Results Page: 1

[Delete](#) [Add to Cart](#) [Remove](#)

Line Item Add
 Item Number:
 Quantity:
Add to Cart
My Account
[Edit Account](#)
[Shipping Address](#)
[Order Pad](#)
[Order History](#)
[Saved Orders](#)
[Review Orders](#)
Shipping Lists
[New](#)
[Favorite Company Purchased](#)
Top Items
[Wish List](#)
[View Wish List](#)
User Settings
 User Name:
 Customer:
 Warehouse: 12 - Denver (McGee Company)
 Shipping Address:
 Phone Number:



McGee Company
1140 South Jason Street
Denver CO 80223

PRSR STD
U.S. POSTAGE
PAID
DENVER, CO
PERMIT NO 1772



ATTN: ROUTE TO SERVICE DEPARTMENT

©2014 McGee Company, Denver, Colorado

McGeeCompany.com • 1-800-525-8888

McGee Company Tire Repair Material

ROUND RADIAL TIRE NAIL HOLE PATCHES

Special Rubber Reinforced Units



| McGee No. | Compare to Xtra Seal No. | Amount | Description | Sale Price |
|-----------|--------------------------|--------|----------------------------|----------------|
| 01589T | 11321 | 100 | 1-9/16" Round Radial Patch | \$19.95 |
| 01590T | 11322 | 60 | 2-1/8" Round Radial Patch | \$17.95 |
| 01592T | 11323 | 40 | 3-1/8" Round Radial Patch | \$16.95 |

Patches in tubs

Dill – OE Snap-In Tubeless Tire Valves

Made with special rubber compound to resist ozone damage and prevent premature deterioration caused by rim hole compression, heat, cold. Maximum inflation pressure is 65 P.S.I.

| Valve Hole | McGee No. | TR No. | Effective Length | Standard Pack Box | Price |
|------------|-----------|--------|------------------|-------------------|------------------|
| .453 | 412R | 412 | 7/8" | 500 | \$.22 ea. |
| .453" | TR413 | 413 | 1 1/4" | 500 | \$.23 ea. |
| .453" | 414R | 414 | 1 1/2" | 500 | \$.28 ea. |
| .453" | 423R | 423 | 1 1/2" | 500 | \$.42 ea. |
| .453" | 418R | 418 | 2" | 500 | \$.33 ea. |
| .625" | 415R | 415 | 1 1/2" | 500 | \$.31 ea. |
| .625" | 425R | 425 | 2" | 500 | \$.52 ea. |

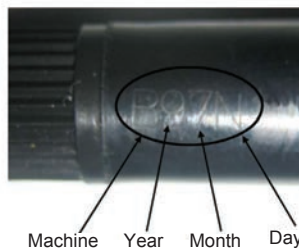

Snap-in tire valves have become a commodity even though they are critical in maintaining the correct tire pressure. As questions arise regarding the life of rubber components and as an effort to provide traceability for this product line, Dill provides a solution! Each Dill stem has the production data etched on it!
Now! Economical Asian stems TR413IV – \$.14 ea. TR418IV - \$.19 ea.



5LD74 empty pouch available!

#MTK Pouch \$25.95

Includes:

- 1 ea GA115 Gauge 20- 120 PSI
- 1 ea MK White Markal
- 1 ea 1246D Flip Socket 3/4-13/16 Thin Wall
- 1 ea 1291DT Flip Socket 19mm-21mm
- 1 ea 595TM Trend Depth Gauge
- 1 ea TL620 Core Tool

McGee Company offers free assembly of air hose to your required length!

Air Hose



Made in the USA



Rubber Air Hose

1/4", 3/8" & 1/2" Multi Purpose Air Hose Assemblies Smooth cover, 300 PSI W.P., 1,200 lb. burst. Limited oil resistance tube & cover. Red.

| Mfg. No. | Description | Price |
|----------|------------------------------------|----------------|
| W64RJ25 | 25', 3/8" Male NPT Hose, 23/32" OD | \$27.16 |
| W64RJ50 | 50', 3/8" Male NPT Hose, 23/32" OD | \$49.50 |
| W84RJ25 | 25', 1/2" Male NPT Hose, 7/8" OD | \$39.95 |
| W84RJ50 | 50', 1/2" Male NPT Hose, 7/8" OD | \$69.95 |

Largest stock of tire chains in the Rocky Mountain Area!



Wide Base Truck Cam Chains

Autosock

DUO Tractor Chains